

Dongguan Hongke Lighting Co.,LTD

Tel:86-769-28682546

Fax:86-769-28682546

Email:sales1@hklighting.com.cn

LED Product Specifications

Product Type: HNK-HP0002UVC2-GC5050

Version No.: 01

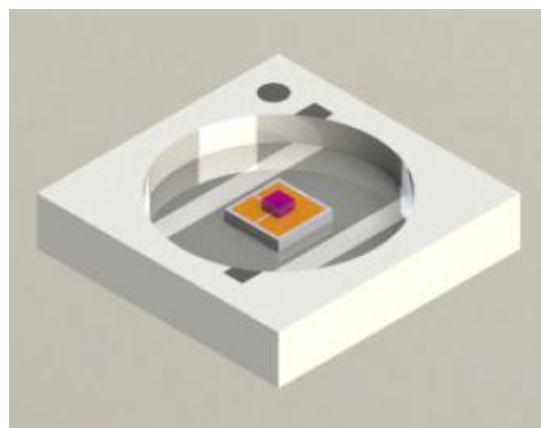

Dongguan Hongke Lighting Co.,LTD

Tel:86-769-28682546

Fax:86-769-28682546

Email:sales1@hklighting.com.cn

Top View

Side View

Bottom View

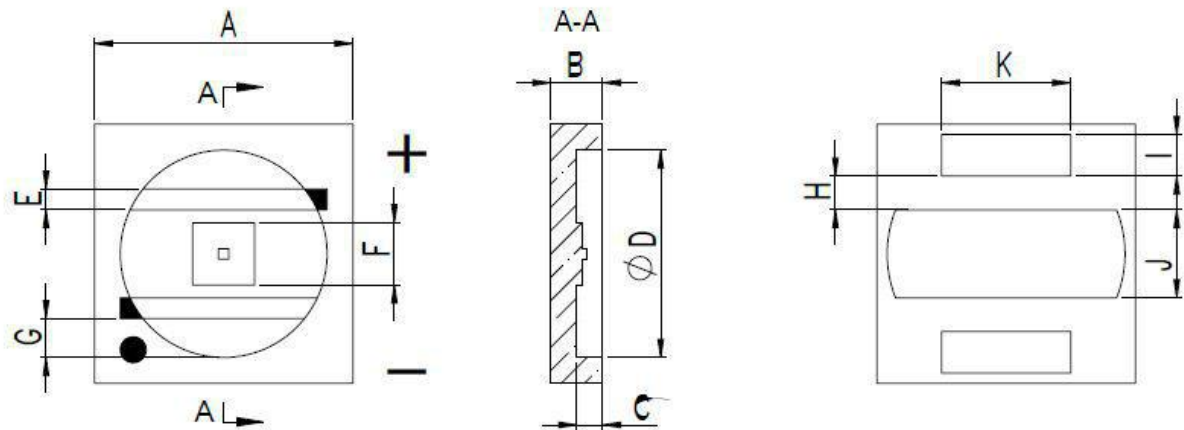

Size details:

Size	Minimum	Standard	Maximum
A	4.8	5.0	5.2
B	0.92	1	1.08
C	0.45	0.5	0.55
D	3.85	4	4.15
E	0.3	0.4	0.5
F	1.1	1.2	1.3
G	0.65	0.75	0.85
H	0.55	0.65	0.75
I	0.7	0.8	0.9
J	1.6	1.7	1.8
K	2.4	2.5	2.6

Dongguan Hongke Lighting Co.,LTD

Tel:86-769-28682546

Fax:86-769-28682546

Email:sales1@hklighting.com.cn

Distribution Curve Flux:

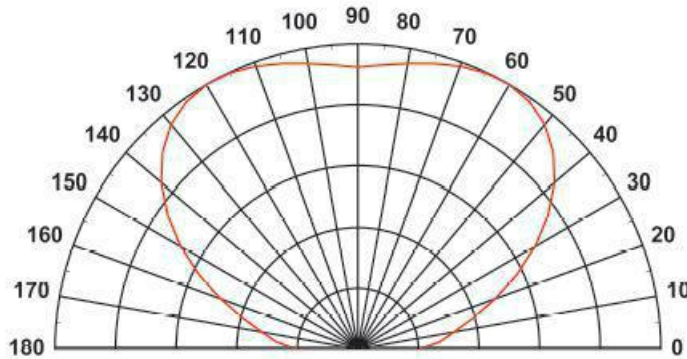

Characteristics Of SMD

1. Electro-Optical Characteristics at 20mA

Peak Wavelength: (nm)	265	280	310
Forward Voltage: (V)	5.5-8.0	5.0-7.0	4.5-6.5
Radiant Flux: (mW)	0.2-1.5	0.5-3.0	0.5-3.0
Viewing Angle: (°)	140°	140°	140°
Pulsed operation: (100mA, 1KHZ duty ratio 5%)	Yes	Yes	Yes
Operating Temperature: (°C)	-30~+55	-30~+55	-30~+55
Storage temperature: (°C)	-30~+55	-30~+55	-30~+55

Notes:

1. It's use Al₂O₃ ceramic and 5050 holder to encapsulation.
2. Small volume, it's convenient for miniaturization of product design.
3. Coefficient of heat release 10W/m.k
4. It's suitable for all kinds of disinfect and curing light and so on.