

NCS-TT106

Temperature Transmitter





Contents

1.	Brief Introduction.....	1
2.	Installation.....	2
	2.1 Dimension.....	2
	2.2 Installation.....	2
	2.3 Wiring.....	3
3.	FF Temperature Transmitter Configuration.....	5
	3.1 Topology Connection.....	5
	3.2 Function Block.....	6
	3.3 Function Configuration.....	7
4.	PA Temperature Transmitter Configuration.....	11
	4.1 Topology Connection.....	11
	4.2 Function Block.....	12
	4.3 Function Configuration.....	13
5.	HART Temperature Transmitter Configuration.....	32
	5.1 Topologic Connection.....	32
	5.2 Function Configuration.....	33
6.	Maintenance.....	43
7.	Technical Specification.....	46
	7.1 Basic Parameter.....	46
	7.2 RTD Parameter.....	47
	7.3 Thermocouple Parameter.....	48
	7.4 Physical Parameter.....	49



FIELDCOMM GROUP™
Connecting the World of
Process Automation



HART™
COMMUNICATION PROTOCOL



CERTIFICATE OF MEMBERSHIP

The Board of Directors hereby acknowledges that

Microcyber Corporation

has accepted and fulfilled the requirements of the Bylaws
and all rights and privileges of membership are hereby granted

Membership Term: November 2019 – October 2020



President and CEO



1. Brief Introduction

NCS-TT106 smart temperature module, using the fieldbus technology, is a new generation of smart fieldbus temperature transmitter and it is an indispensable field device for process control. NCS-TT106 transmitter integrates abundant function blocks and realizes not only general measurement function but also complicated control strategy. NCS-TT106 uses digital technology, so it can connect with many types of thermocouple and thermo resistive sensors. It has wide range and simple interface between field and control room, which reduces the expense of installation, operation and maintenance.

NCS-TT106 supports HART, FF, and PA protocols. It can be widely used in the petroleum, chemicals, electricity, and metallurgical industries, etc.

2. Installation

2.1 Dimension

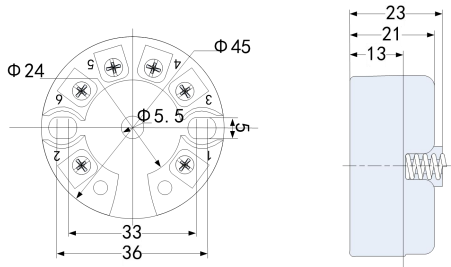

Figure 2.1 Temperature Module Dimension (Unit: mm)

2.2 Installation

Via positioning hole, use two screws to install the temperature module to temperature housing or rail.

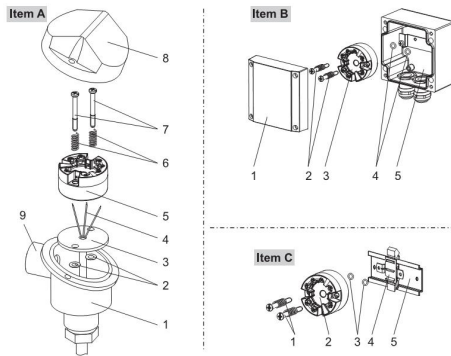

Figure 2.2 Installation

2.3 Wiring

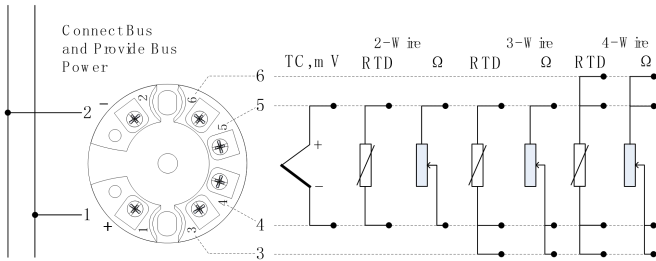

Figure 2.3 Wiring

Fieldbus temperature module's power and bus signal share a pair of cable, and it is called bus cable. It is suggested the user use fieldbus special cable recommended by IEC61158-2.



The signal cable and bus cable cannot share wires or wire slot with other device power wire, and they shall be away from device with high power.

The shielded wires of bus ends shall be connected to the ground.

3. FF Temperature Transmitter Configuration

3.1 Topology Connection

FF transmitter supports many kinds of connection, as shown in Figure 3.1. There is a transmitter bus connection, and the bus ends are connected with terminal matching resistance, which ensures the signal quality. The maximum length of bus is 1900m and it can be prolonged to 10km with repeaters.

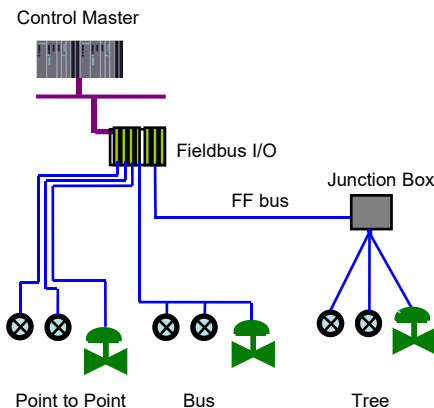

Figure 3.1 FF Network Topology

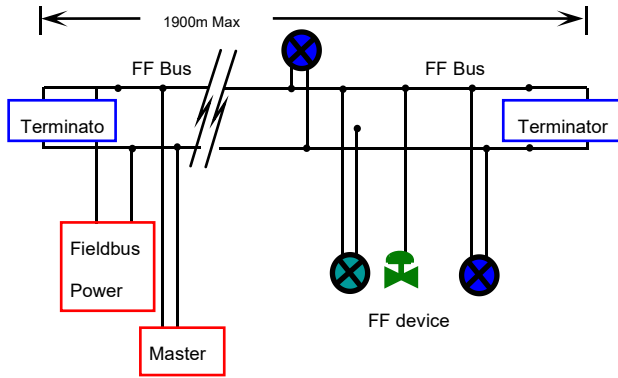

Figure 3.2 FF Bus Connection

3.2 Function Block

FF smart transmitter realizes FF standard function blocks, shown as below. Please refer to related FF protocol documents for detailed info about function block setting.

Function Block	Description
RESOURCE(RB2)	Resource block is used to describe device characters in the field, such as device name, manufacture, serial number. There is no input or output parameter in resource block. Generally there is only one resource block for each device.
TEMP_SENSOR 1(TTB)	Transducer block is used to read sensor hardware data, or write the



	data in the field to related hardware. Transducer block includes the info such as range, sensor type, linearization, I/O data, etc.
AI 1(AI)	Analog input function block is used to achieve transducer block input data and transfer it to other function blocks, and has the function of range conversion, square root, cut mantissa, etc.

3.3 Function Configuration

Smart temperature transmitter supports FF Configuration Software, NCS4000 Configuration Software from Microcyber, NI-FBUS from NI, DeltaV from Rosemont, etc. Now take NI-FBUS from NI as an example to introduction the configuration method of smart temperature transmitter.

- Configuration Environment

- (1) PC, Windows 2000 or Windows XP;
- (2) NI USB-8486, H1 bus power, H1 terminator;
- (3) NI-FBUS Configurator.

- Sensor Type Configuration

Sensor type can be set by modifying transducer block SENSOR_TYPE parameter, such as PT100, CU50, etc.

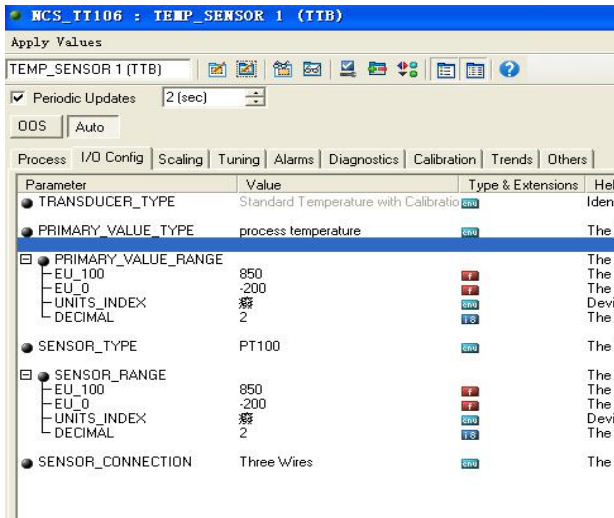

Figure 3.3 Sensor Type Configurations

- **2-wire Zero Point Calibration Configuration**

For 2-wire measurement, 2-wire zero point calibration can be realized by modifying transducer block TWO_WIRES_COMPENSATION parameter. Firstly, give zero point value to channel to make a short circuit. Then set the TWO_WIRES_COMPENSATION parameter as “Start” to write in. If it is successful, read the parameter. If the parameter value is “Finished”, it means that 2-wire zero point calibration is successful.

- **Enable Cold End Temperature Compensation**

If the sensor is thermocouple, the user can set cold end compensation via parameter RJ_TYPE, when it is set as Internal, it enable inside cold end compensation. At this time,



RJ_TEMP value is the temperature value measured inside, that is SENCONDARY_VALUE. When it is set as External, the user can set EXTERNAL_RJ_VALUE to configure fixed cold end compensation value, the RJ_TEMP at this time is EXTERNAL_RJ_VALUE. When it is set as No reference, the cold end compensation is forbidden, shown as Figure 3.4.

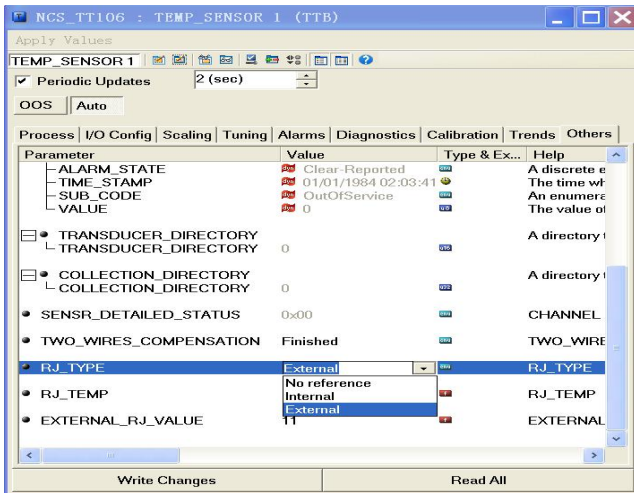

Figure 3.4 RJ_TYPE Configuration

● 2-point Linearization Calibration

Temperature transmitter has strict calibration in factory. Generally, it is not necessary for user to calibrate. The user can use CAL_POINT_HI, CAL_POINT_LO and CAL_UNIT to realize 2-point linearization calibration. The operation steps shown as following:



- (1) Make sure and set SESOR_TYPE, and set CAL_UNIT according to sensor type. Now it supports Celsius, Ohms and MV.
- (2) Set transducer block MODE parameter as “OOS”, and then set the SENSOR_CAL_METHOD as “User Trim Standard Calibration”.
- (3) Give standard data to channel to calibrate via standard source, when the input is stable, write calibration data to CAL_POINT_HI or CAL_POINT_LO according to upper limit calibration or lower limit calibration. It is successful if there is no write error. **Notes: The calibration will be failed if there is a great deviation between write-in calibration data and practical input channel data.**

4. PA Temperature Transmitter Configuration

4.1 Topology Connection

Profibus PA transmitter supports many kinds of connection, as shown in Figure 4.1. There is a transmitter bus connection shown in Figure 4.2, and the bus ends are connected with terminal matching resistance, which ensures the signal quality. The maximum length of bus is 1900m and it can be prolonged to 10km with repeaters.

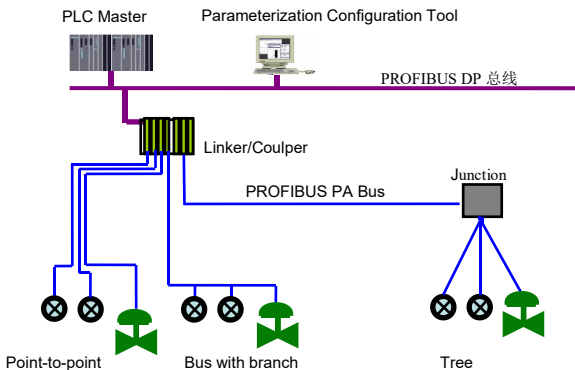

Figure 4.1 PA Network Topology

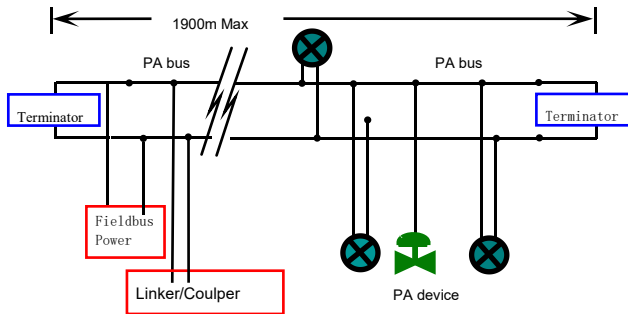

Figure 4.2 FF Bus Connection

4.2 Function Block

PA smart transmitter realizes PA standard function blocks, shown as below. Please refer to related PA protocol documents for detailed info about function block setting.

Function Block	Description
Physical Block	Physical block describes device hardware information, recognizing and diagnosing information, including device tag number, software version, hardware version and installation dates, etc.
Transducer Block	Transducer block separates function blocks from the instrument input and output characteristic, and it mainly realizes the function such as calibration and linearization for input and output



	data, and then provides the processed data to AI via inner channel.
Analog Input Block	AI block gets simulation processing value from the inner channel, and then processes the value, providing proper measurement value to master device via bus communication.

4.3 Function Configuration

PA smart transmitter parameter configuration follows Profibus PA Specification Version 3.02. It can realize read and write function for transmitter function block parameters via Simatic PDM, also is able to configure temperature module via Siemens Step7.

- Configuration Environment

- (1) PC, Windows 2000 or Windows XP;
- (2) Siemens Step7 Configuration Software, Siemens PDM Device Management Software;
- (3) DP/PA coupler or linker;
- (4) 1 Master such as PLC, 2 Master such as CP5611;
- (5) PA Terminator;
- (6) Standard temperature source.

- Temperature Transducer Block Parameter Configuration

Transducer block separates function block from sensors, actuators and other I/O devices. It depends on the device supplier to access and control I/O devices. Transducer block

is able to get input data and set output data by accessing I/O devices. Generally, transducer block has the function of linearization, specialization, temperature compensation and data's control and exchange, etc. Transducer block structure is shown as Figure 4.3.

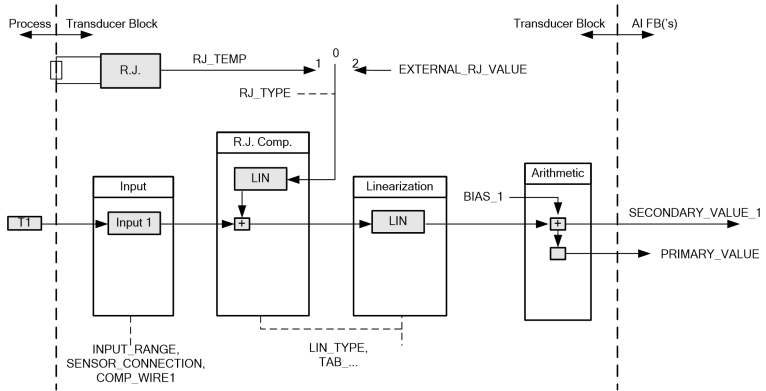

Figure 4.3 Transducer Block Structure

The transducer block parameters as following:

Parameter	Function Description
INPUT_FAULT_GEN	Input fault: includes the failure diagnosed objects of all values. 0: Device normal Bit 0: Rj Failure Bit 1: Hardware failure Bit 2-4: Reservation Bit 5: Manufacture designation Bit 6: Communication failure Bit 7: Manufacture designation



INPUT_FAULT_1	Input fault: the failure diagnosed objects related to SV_1 0: Input normal Bit 0: Higher than the upper range Bit 1: lower than the lower range Bit 2: Break Bit 3: Short Circuit Bit 4-7: Reservation
BIAS_1	Deviation value for processing parameters of Channel 1 Units are designated by PRIMARY_VALUE_UNIT.
INPUT_RANGE	0: mV Range 1 => mV 100 128: Ω Range 1 => Ohm 500 129: Ω Range 2 => Ohm 4000
LIN_TYPE	Linearization type
SENSOR_WIRE_CHEC K_1	Enable open circuit testing and short circuit testing: 0: open circuit testing enable, short circuit testing enable; 1: open circuit testing enable, short circuit testing forbidden; 2: open circuit testing forbidden, short circuit testing enable; 3: open circuit testing forbidden, short circuit testing forbidden.



PRIMARY_VALUE	Temperature module measurement value and status Units are designated by PRIMARY_VALUE_UNIT.
PRIMARY_VALUE_UNIT	Temperature module measurement value engineering unit code
UPPER_SENSOR_LIMIT	Sensor physical upper limit value
LOWER_SENSOR_LIMIT	Sensor physical lower limit value
SECONDARY_VALUE_1 (SV_1)	From Channel 1 and the calibrated value and status calibrated by BIAS_1. Units are designated by PRIMARY_VALUE_UNIT.

Thermocouple additional parameters as following:

Parameter	Function Description
EXTERNAL_RJ_VALUE	External reference point temperature can be input automatically. Units are designated by PRIMARY_VALUE_UNIT. If the unit is not for temperature, it should be set as °C.



RJ_TEMP	Reference point temperature. Unit is set by PRIMARY_VALUE_UNIT. If the unit is not for temperature, it should be set as °C.
RJ_TYPE	Setting reference point type, coding as follows: 0: No reference, no compensation. 1: Inner, temperature at reference point self-tested by the device. 2: Outer, temperature at reference point from outer. Choose 1 when in default.

Thermo resistance additional parameters as following:

Parameter	Function Description
SENSOR_CONNECTION	It can be used to connect sensor with 2-wire or 3-wire. 0: 2-wire 1: 3-wire 2: 4-wire

Parameters defined by manufacture as following:

Parameter	Function Description
SENSOR_VALUE_1	Original data value for sensor 1.
CAL_POINT_HI	Calibration value at the highest point;



	The unit is designated by CAL_UNIT.
CAL_POINT_LO	Calibration value at the lowest point; The unit is designated by CAL_UNIT.
CAL_MIN_SPAN	Allowable minimum step length during the calibration ensures the calibration smoothly, and the distance between highest point and lowest point is not too close. The unit is designated by CAL_UNIT.
CAL_UNIT	Calibration units (°C, Ω, mV)
TWO_WIRES_COMPENSATION	2-wire zero point compensation
R0 ADJUST	Used to calibrate the sensor connected to temperature module

● PROFIBUS periodic data communication configuration
PROFIBUS DP periodic data communication is to exchange input output data, between 1 master and slave station, in the polling way. The communication method is non-connected. In every cycling period, 1 master sends data exchange request, the slave answers it passively. The periodic data communication is mainly applied in configuration between

slave and PLC master. With it, master PLC receives slave input data or output the data to slave station.

PA smart temperature module periodic data communication configuration is similar to PROFIBUS DP slave, only a coupler or a linker between PA bus and DP bus is needed to add between PA bus and DP bus.

PA smart temperature module periodic data comes from output parameters of AI function block. There are 5 bytes, including 4 bytes of temperature floating data and 1 byte status byte. As for periodic communication, 2 identifiers are supported by transmitter, they are, short identifier 0x94 and long identifier 0x42, 0x84, 0x08 and 0x05. The user may use Siemens Step7 to configure periodic data communication for PROFIBUS PA.

Following is an example for configuration via Siemens Step7:

Turn on SIMATIC Manager, select PLC master and create a new project, shown as Figure 4.4.

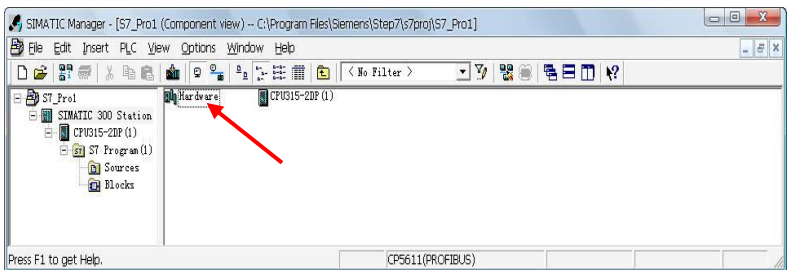

Figure 4.4 Select PLC Master and Create a New Project



Click Hardware twice to turn on HW Config Software Hardware Configuration. Select Install GSD to install PA temperature module GSD file in Option list, shown as Figure 4.5.

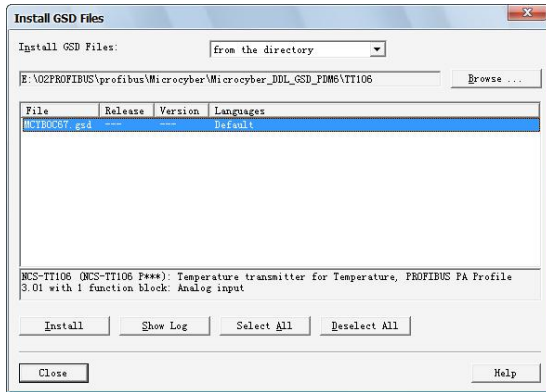

Figure 4.5 Install GSD

After GSD file is installed successfully, the installed PA device will be listed in the PROFIBUS-PA index MicrocyberInc.on the right of HW Config Software. Click it and drag it to the PROFIBUS DP bus, shown as Figure 4.6.

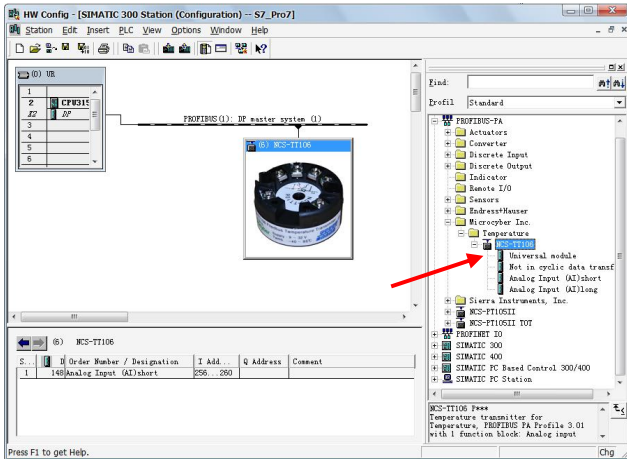

Figure 4.6 Drag PA Devic to PROFIBUS DP Bus

Download the configuration information to PLC master in the PLC list. Then the periodic data communication configuration between PA instrument and master is finished, shown as Figure 4.7.

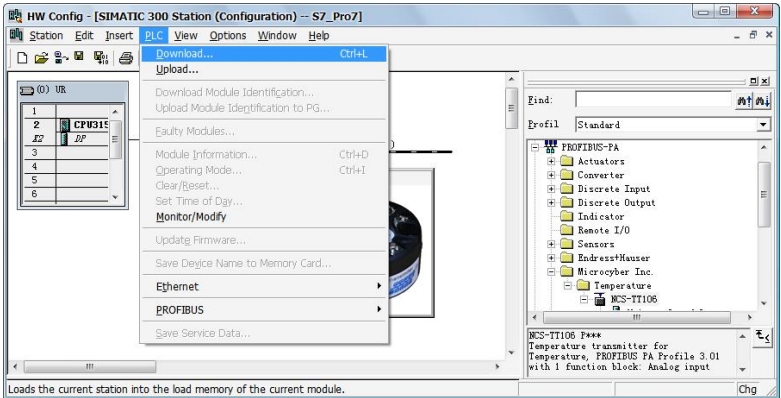

Figure 4.7 Download Configuration Info to PLC



- PROFIBUS non-periodic data communication configuration

PROFIBUS DP non-periodic data communication is the data communication between 2 master and slave, facing connection. The data communication is non-periodic, without affecting periodic data communication. The non-periodic data is mainly PA function block parameters, together with recognizing and diagnosing information for the device. The non-periodic data communication is mainly applied in management, recognizing, diagnosing, testing, maintaining for PA device.

Siemens device management software SIMATIC PDM can be used to realize the non-periodic data configuration for PA instrument.

There is an example given below to show non-periodic data configuration for PA instrument.

Open the LifeList software attached by SIMATIC PDM, select Start to scan DP bus in Scan list, shown as Figure 4.8.

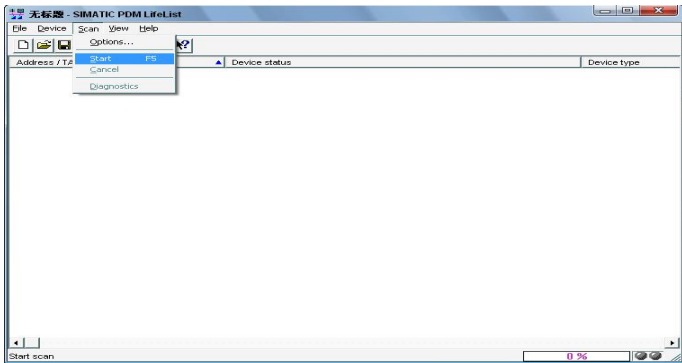

Figure 4.8 Start LifeList

After scanning the bus, slave device in DP bus will be listed; meanwhile the device manufacture ID number and some diagnosing information are displayed, shown as Figure 4.9.

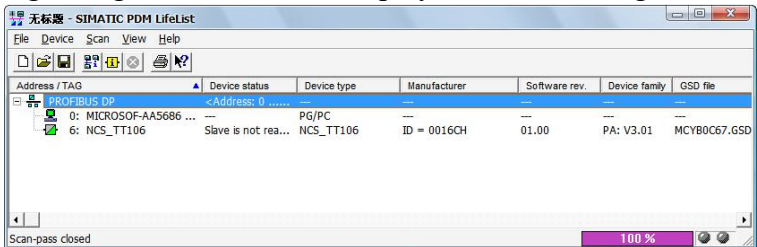

Figure 4.9 Scan DP Bus and List PA Device

Click PA device twice to start SIMATIC PDM software. The user may read, write and diagnose parameter for PA device. Select the Device catalog... when the user is asked to select the PA instrument type, lead the GSD document. Microcyber Inc\NCS-TT106 can be selected for the NCS-TT106 series of PA temperature module, shown as Figure 4.10.

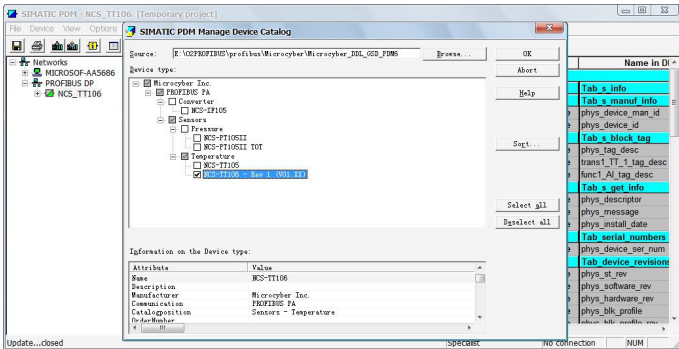

Figure 4.10 Select Device Type

After selecting the device type, click OK, thus non-periodic data communication is configured successfully. Via the function of upload and download function of PDM Software, the parameter read and write can be realized, shown as Figure 4.11.

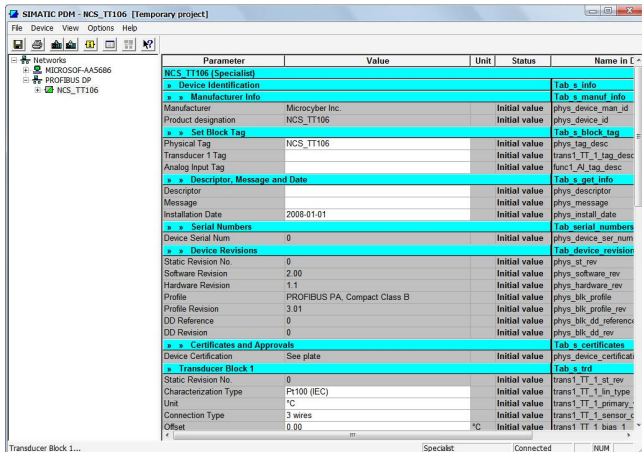

Figure 4.11 Device Management via PDM Software



- Configuration Function

PA smart temperature module realizes PA standard function blocks. With PDM software, after configuration, choose Device -> Configuration, to do operation for transducer block or AI function block.

- Sensor Type Configuration

Sensor Type can be set by modifying Characterization Type of transducer block and Input Range and Mode Parameters. E.g. PT100, CU50, etc. When Characterization Type Parameter is Linear, Input Range and Mode Parameter is effective.

- 2-wire Zero Point Calibration Configuration

For 2-wire measurement, the user may use `TWO_WIRES_COMPENSION` parameter to do zero point calibration. First, give zero value to the channel, which will cut the channel off. Next, turn on PDM software, after the configuration, choose Device -> Configuration -> Transducer Block 1. In Advanced Settings, there is 2-wire calibration function. After pressing write button, when Finished is displayed, it means 2-wire zero point calibration is successful.

- Enable Cold-end Temperature Compensation

When thermocouple is used as sensor, Reference Junction Temperature parameter of transducer block is cold-end temperature value. Primary Value is measurement value referenced cold-end temperature value. If 0°C is to display



in primary value output, it can be realized by setting Reference Junction parameter. If 1°C is to display in primary value output, it can be realized by measurement temperature as well as cold-end temperature as Primary Value output. The cold-end temperature compensation is enabled in default.

- 2-point Linearity Calibration

The strict calibration must be done to temperature module in the factory, so it is not necessary for users to calibrate again. The parameters such as Lower Calibration Point, Upper Calibration Point and Calibration Unit are used to carry out 2-point linearity calibration. The operation steps are as following:

- (1) Turn on PDF software, after configuration; choose Device -> Calibration -> Lower/Upper, get page of temperature calibration.
- (2) Make sure of sensor type, set Characterization Type and Input Range and Mode, and set Calibration Unit according to sensor type. It supports the parameters °C, Ω, and mV. Write the parameter after the setting.
- (3) Give standard data to channel to calibrate via standard source. When the input is stable, write calibration data to Upper Calibration Point or Lower Calibration Point according to the operation one is upper calibration or lower calibration. If there is no write error, the calibration is successful. **Notes: There should not be a**



great deviation between written calibration data and practical input channel data, otherwise the calibration will be in failure.

Notes: When the user uses Device -> Master Reset, it may bring in the instrument CPU reset as well as communication broken, which is normal. Please connect again.

- Modify Device Main Parameters via GSD file

In STEP7 hardware configuration, there are 2 methods to modify parameters:

- (1) Click the device via the right button, and choose prosperity, to configure transducer block main parameters;
- (2) Click the AI in Slot via the right button, and choose prosperity, to configure AI function block main parameters.

Notes:

Get Figure 4.12 according to Method 1, after modifying Parameterization parameter to DPV0+DPV1, the rest modification for parameters shall be effective. If DPV1 only is chosen, the 2 parts of parameter modification are not effective.

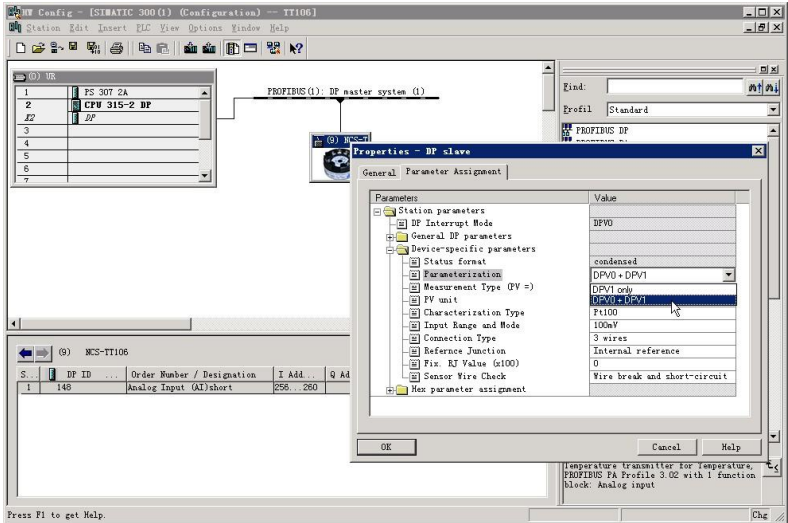

Figure 4.12 Device Parameter Modification

In the device parameter part, the parameters can be modified are shown as following.

Parameter	Name in GSD
PRIMARY_VALUE_UNIT	PV unit
LIN_TYPE	Characterization Type
INPUT_RANGE	Input Range and Mode
SENSOR_CONNECTION	Connection Type
RJ_TYPE	Reference Junction



EXTERNAL_RJ_VALU E	Fix. RJ Value (x100)
SENSOR_WIRE_CHEC K_1	Sensor Wire Check

PRIMARY_VALUE_UNIT and LIN_TYPE、
INPUT_RANGE shall match correctly. Otherwise, the
device shall alarm parameterization error, which makes the
device not in data exchange mode.

The correct match as following:

When LIN_TYPE is Linear, parameter INPUT_RANGE is
effective.

When INPUT_RANGE is 100 mV,
PRIMARY_VALUE_UNIT is mV.

When INPUT_RANGE is 0-500 Ohm or 0-4000 Ohm,
PRIMARY_VALUE_UNIT is Ohm.

When parameter LIN_TYPE is other configured sensor type
(thermocouple, thermo resistance) ,

PRIMARY_VALUE_UNIT could be degC, degF, K or
degR.

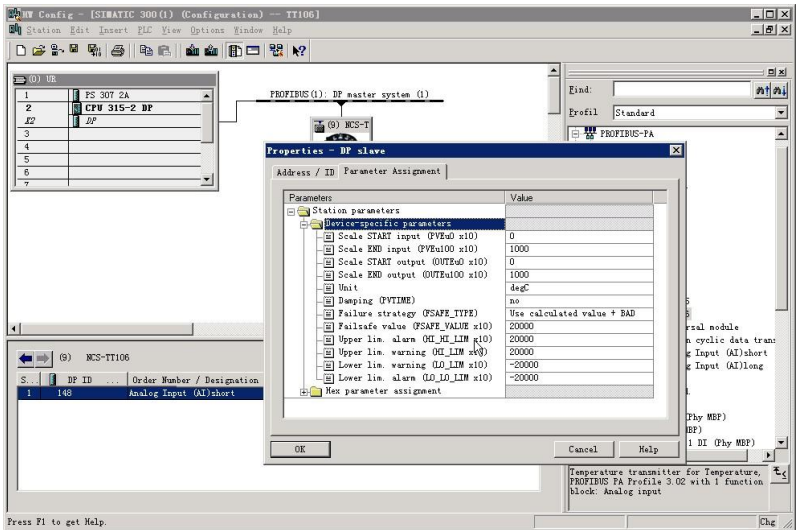

Figure 4.13 AI Function Block Parameter Modification

In AI function block parameter parameter part, the parameters can be modified are shown as following.

Parameter	Name in GSD
PV_SCALE.EU_at_0%	Scale START input (PVEu0 x10)
PV_SCALE.EU_at_100%	Scale END input (PVEu100 x10)
OUT_SCALE.EU_at_0%	Scale START output (OUTEu0 x10)
OUT_SCALE.EU_at_100%	Scale END output (OUTEu100 x10)



OUT_SCALE. Units_Index	Unit
PV_FTIME	Damping (PVTIME)
FSAFE_TYPE	Failure strategy (FSAFE_TYPE)
FSAFE_VALUE	Failsafe value (FSAFE_VALUE x10)
HI_HI_LIM	Upper lim. alarm (HI_HI_LIM x10)
HI_LIM	Upper lim. warning (HI_LIM x10)
LO_LIM	Lower lim. warning (LO_LIM x10)
LO_LO_LIM	Lower lim. alarm (LO_LO_LIM x10)

5. HART Temperature Transmitter Configuration

5.1 Topologic Connection

The connection of HART smart transmitter includes 4~20mA compatible mode and networking mode.

- 4~20mA compatible mode, shown as Figure 5.1.



Figure 5.1 4~20mA Compatible Mode

Feature:

- (1) Connected to the above control system above via AI module and HART communication device
- (2) Mixed use of the analog and digital communication
- (3) The device address is 0.

- Networking mode, shown as Figure 5.2.



Figure 5.2 Networking Mode

Feature:

- (1) Connected to the above control system via HART communication device;
- (2) Only use digital function of HART device, and the fixed current on wire is 4mA;
- (3) Support 15 devices in the mode of short address.

5.2 Function Configuration

Smart temperature supports Microcyber's HartMPT Configuration Software and universal software such HART Organization's SDC625 for configuration debugging. Following is an example for HartMPT Configuration Software, including functions:

- (1) Basic information configuration: configure the basic information of device online, including tag, address, date, assemble number and so on;



- (2) Configurable information configuration: configure the configurable information of device online, including primary variable range, damp and so on;
- (3) Sensor info configuration: configure the sensor info of the online device, including type, wiring, etc.;
- (4) Current calibration: Can calibrate 4~20mA current of online device, also can set fixed current output;
- (5) Variable monitoring: refresh all dynamic variable of selected online device timely and display trend curve of present device primary value.

- Configuration Environment

- (1) PC with serial port, Windows 2000 or Windows XP;
- (2) HART Modem and serial wire;
- (3) Matching resistance $250\ \Omega \sim 550\ \Omega$.

- Basic Information Configuration

Through basic information dialog, the basic information of the smart transmitter can be read or modified, including device address, information, description, date, assembly number, alarm, write protection, manufacturer ID, manufacture, device type, device ID, long address and version info, shown as Figure 5.3.

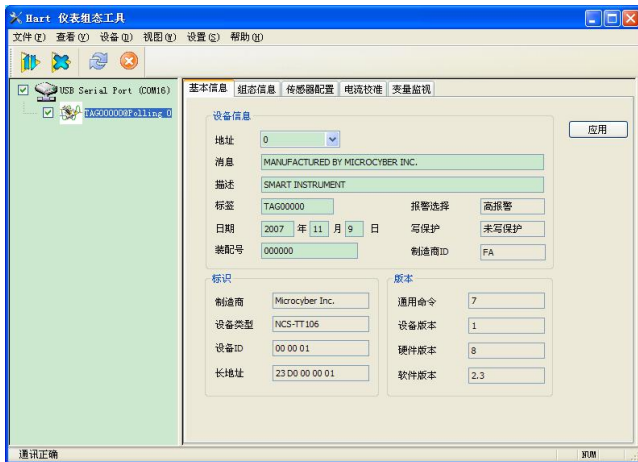

Figure 5.3 Basic Information

After information modification, click the “Apply” button to download it into device.

- (1) The address selection range is 0~15;
- (2) Information can be input 32 characters at most;
- (3) The maximum length of the description is 16 defined characters;
- (4) The maximum length of the tag is 8 defined characters;
- (5) Date range is from the year 1900 to 2155.
- (6) Assembly number is 6 defined characters at most.

● Configuration Information Setting

Through configuration information dialog, the configuration information of smart transmitter can be read or modified, including displayed device output variable (primary variable, cold end temperature value, current value and percentage),



primary variable info setting (damp value, unit, upper limit and lower limit) and range calibration, etc., shown as Figure 5.4.

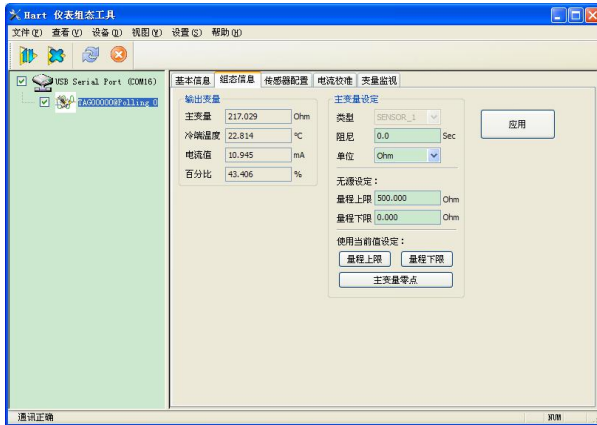

Figure 5.4 Configuration Information

- Damp: range 0~32s
- Unit: PV unit modification affects variables related to unit, such as the upper or lower limit for the range or for the sensor. When you modify the unit, you can't modify upper or lower limit for the primary variable range, instead, you should modify them separately.
- The unit can be set as: °C, °F, °R, K, mV, Ohm.
- Upper limit of the range: Corresponding to PV value of 20mA output current.
- Lower limit of the range: Corresponding to PV value of 4mA output current.



You should press “Apply” to download it into device after the modification.

- Set “upper limit of range” with present value: Set the PV as the upper limit of primary variable range, and keep the lower limit of range the same as previously.
- Set “lower limit of range” with present value: Set the PV as the lower limit of primary variable range, it may probably modify upper limit at the same time.
- Set “primary variable zero point” with present value: Set the PV as the primary variable zero point when the temperature is 0 ° C.
- Sensor configuration

You may check the current configuration sensor info (upper limit, lower limit and minimum span) via sensor info TAB. Also, you may configure the sensor type and wiring with it, shown as Figure 5.5.

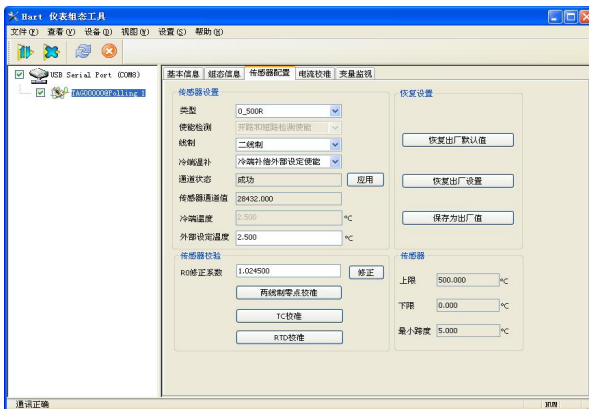

Figure 5.5 Sensor Configuration



Sensor Type: Sensor type supported by device, shown as following:

Sensor Type	Description
SCALE_0_500R	Resistance, 0 ~ 500Ω
SCALE_0_4000R	Resistance, 0 ~ 4000Ω
SCALE_CU50	Cu50 RTD
SCALE_CU100	Cu100 RTD
SCALE_PT100	PT100 RTD
SCALE_PT1000	PT1000 RTD
SCALE_100MV	MV voltage signal, range from -100 to +100 mV
SCALE_B_TC	B type thermocouple
SCALE_E_TC	E type thermocouple
SCALE_J_TC	J type thermocouple
SCALE_K_TC	K type thermocouple
SCALE_N_TC	N type thermocouple
SCALE_R_TC	R type thermocouple
SCALE_S_TC	S type thermocouple
SCALE_T_TC	T type thermocouple

- Wiring: It can be set as 2-wire or 3-wire, only effective to RTD.
- Cold-end Compensation: It enables or disables thermocouple's cold-end compensation function. When the user is using internal cold-end compensation, the present cold-end compensation value is internal measurement temperature value. When the user is using



external cold-end compensation, the user may use “external setting temperature value” to set fixed cold-end compensation value.

- Channel status: Display sensor channel status (open circuit, short circuit, etc.)
- Sensor channel value: Display original value of sensor channel.
- External setting temperature: When external cold-end compensation is set as “Enable”, the present cold-end compensation value can be set via “external setting temperature”.
- Cold-end compensation temperature: Display present cold-end temperature compensation value.
- R0 correction factor: Correct the sensor’s own error (range 0.9~1.1).
- 2-wire zero point calibration: When the temperature transmitter is connected to RTD in 2-wire way, in order to avoid the resistance error in the cable, you should short-circuit the sensor and execute zero point calibration button.
- TC calibration: Factory calibration for thermocouple ranges. (only for manufacturer)
- RTD calibration: Factory calibration for thermo resistances ranges. (only for manufacturer)
- Recover to factory default value: Click this, all the data shall be recovered to factory default status.



- Save as factory value: Click this, all the present setting shall be saved as factory value. Click “Recover to factory”, it shall be recovered to the saved setting.
- Recover to factory setting: Click this, all the data shall be recovered to factory status. If the user has saved factory value, then it shall recover to user’s saved setting. Otherwise, it shall be recovered to default factory status.

- Current Calibration

The steps of current calibration are shown as following:

- (1) Connect the loop, an ammeter with the 5 1/2 digit precision should be series-wounded in the device output loop.
- (2) Set device rolling address as 0, please refer to basic info configuration. If rolling address is 0 already, this step can be skipped.
- (3) Enter current calibration option TAB.
- (4) Select “current value” as 4mA, when the ammeter is stable, input the value in ammeter to “adjustment value”, and then click “Apply”.
- (5) Select “current value” as 20mA, when the ammeter is stable, input the value in ammeter to “adjustment value”, and then click “Apply”.
- (6) Select “current value” as blank, makes the device output current as PV value.

- Configure Current Fixed Output



The user may set fixed current output in current calibration tab. Input the value of the current the smart transmitter will be fixed on, to “fixed current value”, and click the button “enter/exit fixed current mode” to enter or exit the mode of fixed current output. The text of the button can display “exit fixed current mode” and “enter fixed current mode” in turn, to tell users what to do.

In the run of the HART smart transmitter, compare the value of the primary variable and range upper/lower limit of the primary variable continuously. When the value of the primary variable exceeds the range of the primary variable, the smart transmitter will output fixed current to indicate that the value of the primary variable is exceeded. When it is over the upper limit, the smart transmitter output fixed current 20.8mA; When it is less than the lower limit, output is 3.8mA.



Figure 5.6 Current configuration

Note: Calibration current and fixed current output functions are only in the moment when the polling address is 0. It will be at absolute digital communication mode at other polling addresses, the failure info is “Command Execution Failure”.

● Variable Monitoring

The user is able to refresh all the dynamic variables of the selected device and display trend curve of present device primary variable via variable monitoring tab. The present refreshing variables are: PV value, current value, percentage and cold end temperature.

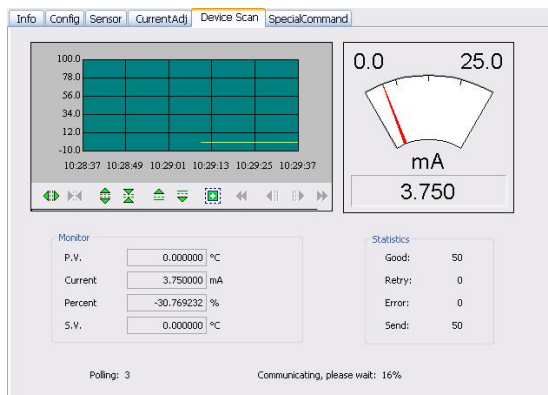

Figure 6.7 Variable Monitoring



6. Maintenance

Phenomenon	Solution
No Communication	Temperature Module Connection Check the bus cable connection Check bus power polarity Check bus cable shield, whether it is single point earthing or not
	Bus Power Bus power should in the range 9 ~ 32V for the temperature module, and bus noise and ripple should fulfill: (1) peak-to-peak value noise 16mV, 7~39kHz; (2) peak-to-peak value noise 2V, 47~63HZ, non-intrinsically safety (3) peak-to-peak value noise 0.2V, 47~63HZ, intrinsically safety (4) peak-to-peak value noise 1.6V, 3.9M~125MHZ.
	Network Connection Check network topology structure Check terminal matcher and wiring Check the length of main trunk and branch



	<p>Address Conflict</p> <p>When coming to market, the temperature module has a random address, avoiding address conflict. But on a network segment it still possibly appears address conflicts. When conflict occurs, sometimes conflicting device will be temporary address online, you should just reset the device address. Sometimes device will not be temporary address online, you should cut off the electricity of conflicting device, and then power them one by one, modify the address of new powered device as non-conflicting.</p>
	<p>Temperature Module Failure</p> <p>Replace the temperature module with others for testing.</p>
Reading Error	<p>Temperature Module Connection Failure</p> <p>Check sensor short circuit, open circuit, and earthing. Check sensor</p>
	<p>Noise Disturb</p> <p>Adjust damping Check the house earthing Check the terminal Check the cable is away from the strong</p>



	electromagnetic interference
	Software Configuration Check sensor type configuration Check function block parameter configuration
	Temperature Module Failure Replace the temperature module with others for testing.



7. Technical Specification

7.1 Basic Parameter

Input Signal	Resistance: PT100, CU50, CU100, 0~500Ω, 0~4000Ω Thermocouple: B, E, J, N, K, R, S, T Voltage signal: -100mV~100mV
Channel	Single
RTD Wiring	2-wire, 3-wire, 4-wire
Bus Power	9~32 VDC Current consumption (static): ≤14mA
Bus Signal	Communication ratio 31.25Kbit/s, current mode
Isolation	Between terminal and housing: 500 Vrms (707 VDC)
Working Temperature	-40°C~85°C
Humidity Range	10%~90%RH
Start Time	≤5s



Refresh Time	0.5s
EMC	GB/T 18268-2000
Protection	IP20

7.2 RTD Parameter

- RTD Parameter at Normal Temperature (25°C)

Signal Type	Suggested Range (°C)	Accuracy
Resistance Signal	0~500 Ω ,0~4000 Ω	±0.05%
PT100	-200~850°C	±0.2°C
PT1000	-200~850°C	±0.1°C
CU50	-50~150°C	±0.3°C
CU100	-50~150°C	±0.2°C

- RTD Other Parameter

Wiring	2, 3, 4
Common Mode Rejection	≥70Db (50Hz and 60Hz)
Series Mode Rejection	≥70dB(50Hz and 60Hz)
Temperature Effect	<50ppm/°C



7.3 Thermocouple

Parameter

- Thermocouple Parameter at Normal Temperature (25°C)

Signal Type	Suggested Range (°C)	Accuracy
mV	-100mV~100mV	0.05%
B	500°C~1810°C	±1.0°C
E	-200°C~1000°C	±0.4°C
J	-190°C~1200°C	±0.4°C
K	-200°C~1372°C	±0.4°C
N	-190°C~1300°C	±0.8°C
R	0°C~1768°C	±1.0°C
S	0°C~1768°C	±1.0°C
T	-200°C~400°C	±0.4°C

- Thermocouple Other Parameter

Compensation Accuracy	-2°C~5°C
Sensor Type	B,E,J,N,K,R,S,T -100mV~100mV Voltage
Common Mode Rejection	≥70Db (50Hz and 60Hz)



Series Mode Rejection	$\geq 70\text{dB}(50\text{Hz and } 60\text{Hz})$
Temperature Effect	$< 50\text{ppm}/^\circ\text{C}$

7.4 Physical Parameter

Dimension	$\phi 45*23\text{mm}$
Housing Material	Nylon



MICROCYBER

YOUR FIELDBUS EXPERT

CONTACT INFORMATION

**Address: 17-8 Wensu Street, Hunnan New
District, Shenyang, China**

Website: www.microcyber-fieldbus.com

Phone: +86-24-31217278/+86-24-31217280

Fax: +86-24-31217338

Email: guo.ruibing@microcyber.cn