

序号/Rev.No.	名称/Title	文件编号/File No.
1	XY301S 端子	QJ/XYT-2125501
2	XY301 弹片	QJ/XYT-2225101
3	XY30-C 螺丝	QJ/XYT-2125502
4	XY301S 塑件	QJ/XYT-2125503

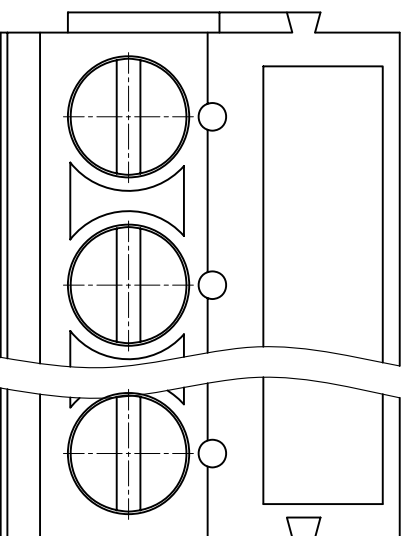
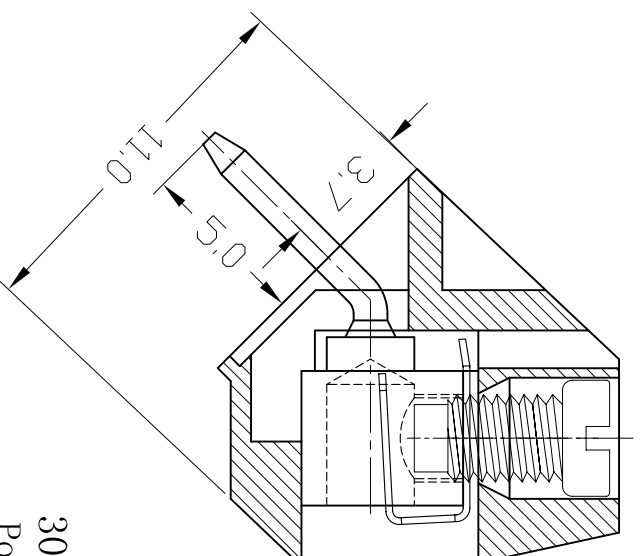
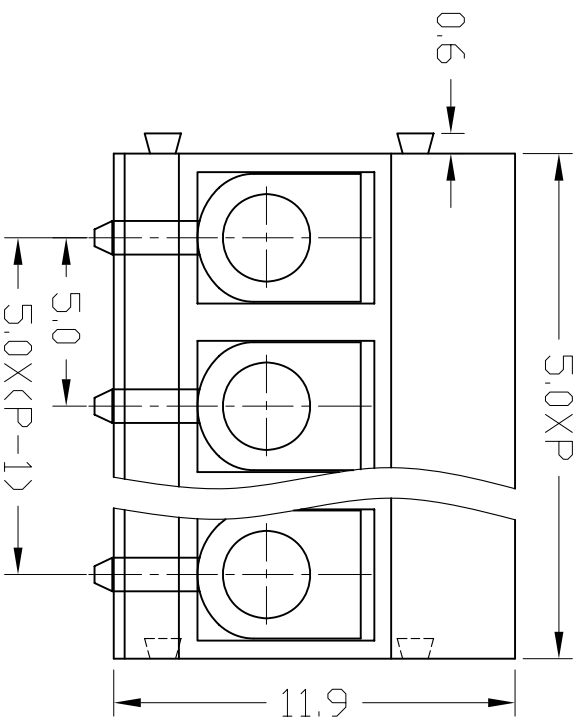

300V 15A 22-14AWG 1.5mm<sup>2</sup>  
Poles: 2P&3P-24P  
Pitch: 5.0mm (.197")

### Materials

Housing: PA66 (UL 94V-0)  
Wire Protector: Stainless Steel  
Solder Pin: Brass, Tin Plated  
Screw: M2.5, Steel (A3), Zinc Plated  
Torque: 0.4N.m

设计/Designed by	绘图/Drawing by	审核/Checked by	批准/Approved by	未注公差 General Tolerance	
				x, .x, .xx, .xxx	x°, .x°, .xx°, ±0.5°
		图名/File name	文件编号/File No.	±0.2 ±0.1 ±0.05 ±0.01	±0° ±0° ±0° ±0.5°
		XY301S 产品图	QJ/XYT-2125500		
		页序/Sheet			
备注/Remark				单位/Units: mm	

**新莱亚电子**  
XINLAIYA ELECTRONIC CO., LTD