





## Contents

<b>1 GENERAL</b> .....	<b>5</b>
<b>2 MECHANICAL OVERVIEW</b> .....	<b>5</b>
2.1 DC OUTPUT CONNECTOR.....	5
2.2 HANDLE RETENTION .....	5
2.3 LED MARKING AND IDENTIFICATION .....	5
2.4 ACOUSTIC REQUIREMENTS.....	6
2.5 TEMPERATURE REQUIREMENTS .....	6
2.6 SYSTEM IMPEDANCE .....	6
<b>3 AC INPUT REQUIREMENTS</b> .....	<b>6</b>
3.1 POWER FACTOR.....	6
3.2 AC INLET CONNECTOR .....	6
3.3 AC INPUT VOLTAGE SPECIFICATION .....	6
3.4 AC LINE ISOLATION REQUIREMENTS .....	7
3.5 AC LINE DROPOUT / HOLDUP .....	7
3.5.1 AC Line 12VSBHoldup.....	7
3.6 AC LINE FUSE.....	7
3.7 AC INRUSH.....	7
3.8 AC LINE TRANSIENT SPECIFICATION .....	8
3.9 SUSCEPTIBILITY REQUIREMENTS.....	8
3.10 ELECTROSTATIC DISCHARGE SUSCEPTIBILITY .....	8
3.11 FAST TRANSIENT/BURST .....	8
3.12 RADIATED IMMUNITY .....	8
3.13 SURGE IMMUNITY (PLD).....	8
3.14 POWER RECOVERY .....	9
3.15 VOLTAGE INTERRUPTIONS .....	9
<b>4 EFFICIENCY</b> .....	<b>9</b>
<b>5 DC OUTPUT SPECIFICATION</b> .....	<b>9</b>
5.1 SIGNAL DESCRIPTION .....	9
5.2 OUTPUT POWER / CURRENTS.....	10
5.3 STANDBY OUTPUT.....	10
5.4 VOLTAGE REGULATION.....	10
5.5 DYNAMIC LOADING.....	10
5.6 CAPACITIVE LOADING .....	11
5.7 GROUNDING.....	11
5.8 CLOSED LOOP STABILITY .....	11
5.9 RESIDUAL VOLTAGE IMMUNITY IN STANDBY MODE .....	11
5.10 COMMON MODE NOISE .....	11
5.11 SOFT STARTING .....	11
5.12 ZERO LOAD STABILITY REQUIREMENTS .....	11
5.13 HOT SWAP REQUIREMENTS.....	11

 <b>台達電子工業股份有限公司</b> <b>DELTA ELECTRONICS, INC.</b>				DESCRIPTION : 電氣規格 (Electrical Specification)	
THESE DRAWINGS AND SPECIFICATIONS ARE THE PROPERTY OF DELTA ELECTRONICS, INC. AND SHALL NOT BE REPRODUCED OR USED AS THE BASIS FOR THE MANUFACTURE OR SELL OF APPARATUSES OR DEVICES WITHOUT PERMISSION.				MODEL NO. : <b>DPS-550AB-36 S</b>	
Date	Drawn	Design (EE)	Design (ME)	DOCUMENT NAME. :	REV.
10/18/'21	金雨霞	陳雨	賈曉東	ES-550AB-36 S	S03

5.14 FORCED LOAD SHARING.....	12
5.15 RIPPLE / NOISE.....	12
5.16 TIMING REQUIREMENTS .....	12
<b>6 PROTECTION CIRCUITS.....</b>	<b>14</b>
6.1 CURRENT LIMIT (OCP).....	14
6.2 OVER VOLTAGE PROTECTION (OVP) .....	14
6.3 OVER TEMPERATURE PROTECTION (OTP).....	14
6.4 SHORT CIRCUIT PROTECTION (SCP) .....	14
<b>7 CONTROL AND INDICATOR FUNCTIONS .....</b>	<b>15</b>
7.1 PSON# INPUT SIGNAL .....	15
7.2 PWOK (POWER OK) OUTPUT SIGNAL.....	15
7.3 SMBALERT# SIGNAL .....	16
<b>8 ENVIRONMENTAL REQUIREMENTS.....</b>	<b>17</b>
8.1 TEMPERATURE .....	17
8.2 HUMIDITY .....	17
8.3 ALTITUDE.....	17
8.4 MECHANICAL SHOCK .....	17
8.5 RANDOM VIBRATION .....	17
8.6 THERMAL SHOCK (SHIPPING).....	17
<b>9 FRU REQUIREMENTS .....</b>	<b>17</b>
9.1 FRU DATA .....	17
9.2 FRU DEVICE PROTOCOL .....	17
9.2.1 FRU Data Format.....	18
<b>10 COMMON REQUIREMENTS FOR CRPS.....</b>	<b>18</b>
<b>11 DOCUMENTATION.....</b>	<b>19</b>
11.1 THERMAL EVALUATION.....	19
11.2 SAFETY AGENCY TEST RESULTS .....	19
<b>12 RELIABILITY / WARRANTY / SERVICE.....</b>	<b>20</b>
12.1 LIFE REQUIREMENT.....	20
12.2 MEAN TIME BETWEEN FAILURES (MTBF) .....	20
12.3 WARRANTY PERIOD .....	20
12.4 SERVICEABILITY .....	20
<b>13 PRODUCT REGULATORY REQUIREMENTS.....</b>	<b>20</b>
13.1 PRODUCT SAFETY COMPLIANCE .....	20
13.2 PRODUCT EMC COMPLIANCE – CLASS A COMPLIANCE .....	20
13.3 CERTIFICATIONS / REGISTRATIONS / DECLARATIONS.....	21
13.4 COMPONENT REGULATION REQUIREMENTS .....	21
13.4.1 Harmonics and Voltage Flicker Compliance Information .....	22

 <b>台達電子工業股份有限公司</b> <b>DELTA ELECTRONICS, INC.</b>				DESCRIPTION :	
				電氣規格 (Electrical Specification)	
THESE DRAWINGS AND SPECIFICATIONS ARE THE PROPERTY OF DELTA ELECTRONICS, INC. AND SHALL NOT BE REPRODUCED OR USED AS THE BASIS FOR THE MANUFACTURE OR SELL OF APPARATUSES OR DEVICES WITHOUT PERMISSION.				MODEL NO. :	
				DPS-550AB-36 S	
Date	Drawn	Design (EE)	Design (ME)	DOCUMENT NAME. :	REV.
10/18/'21	金雨霞	陳雨	賈曉東	ES-550AB-36 S	S03

<b>13.5 OTHER SAFETY REQUIREMENT NOTATIONS</b> .....	22
13.5.1 Certification Conditions .....	22
13.5.2 Isolation between Primary - Secondary .....	22
13.5.3 Creepage & Clearance Requirements .....	22
13.5.4 Leakage Current Maximums .....	23
13.5.5 Max Surface Temperatures .....	23
13.5.6 Date Coded Serial Numbers .....	23
13.5.7 Power Input Electrical Ratings .....	23
13.5.8 Maximum Allowable Temperatures on Inlet Receptacles .....	23
13.5.9 Maximum Allowable Temperatures on Power Cords .....	23
13.5.10 China GB4943.1-2011 Tropical Environment .....	23
13.5.11 Insulation resistance .....	23
<b>13.6 POWER SUPPLY, CAGE &amp; MODULE REGULATORY &amp; SAFETY MARKINGS</b> .....	23
<b>13.7 OTHER SAFETY / REGULATORY MARKS ON POWER SUPPLIES</b> .....	23
13.7.1 Power Supply Model Designation .....	23
13.7.2 Electrical Input & Output Ratings .....	23
13.7.3 Shock Hazard & Service Only Warning .....	24
13.7.4 Caution Hot Surface Warning .....	24
13.7.5 Protective Earth Ground Symbol .....	24
13.7.6 Line & Neutral Terminal Markings .....	24
13.7.7 Fuse Markings .....	24
<b>14 FIRMWARE DESCRIPTION</b> .....	25
<b>14.1 PMBUS COMMAND FOR SMART ON</b> .....	25
14.1.1 Hardware Connection .....	25
14.1.2 Configuring Smart On with SMART_ON_CONFIG (D0h) .....	25
14.1.3 Smart Standby Power Supply Operating State .....	25
14.1.4 Powering on Smart Standby supplies to maintain best efficiency .....	26
14.1.5 Powering on Smart Standby supplies during a fault or over current condition .....	26
14.2 Data Formats .....	26
14.3 VOUT_MODE .....	26
<b>14.4 READ_EIN</b> .....	27
<b>14.5 PMBUS COMMAND LIST</b> .....	28

DELTA CONFIDENTIAL

 <b>台達電子工業股份有限公司</b> <b>DELTA ELECTRONICS, INC.</b>				DESCRIPTION : 電氣規格 (Electrical Specification)	
THESE DRAWINGS AND SPECIFICATIONS ARE THE PROPERTY OF DELTA ELECTRONICS, INC. AND SHALL NOT BE REPRODUCED OR USED AS THE BASIS FOR THE MANUFACTURE OR SELL OF APPARATUSES OR DEVICES WITHOUT PERMISSION.				MODEL NO. : <b>DPS-550AB-36 S</b>	
Date	Drawn	Design (EE)	Design (ME)	DOCUMENT NAME. :	REV.
10/18/'21	金雨霞	陳雨	賈曉東	ES-550AB-36 S	S03

# 1 General

This specification defines a 550W common redundant power supply (CRPS) in the 185mm depth form factor that supports server systems. The parameters of this power supply are defined in this specification. This specification defines a power supply with 2 outputs; 12V and 12V standby. The AC input shall be auto ranging and power factor corrected.

# 2 Mechanical Overview

The physical size of the power supply enclosure is 39/40mm x 73.5mm x 185mm. The power supply shall contain a single 40mm fan. The power supply has a card edge output that interfaces with a 2x25 card edge connector in the system. The AC plugs directly into the external face of the power supply. Refer to the below for the CRPS mechanical drawing. All dimensions are nominal.

## 2.1 DC Output Connector

The power supply shall use a card edge output connection for power and signal that is compatible with a 2x25 Power Card Edge connector (equivalent to 2x25 pin configuration of the FCI power card connector 10035388-102LF).

## 2.2 Handle Retention

The power supply shall have a handle to assist extraction. The module shall be able to be inserted and extracted without the assistance of tools. The power supply shall have a latch which retains the power supply into the system and prevents the power supply from being inserted or extracted from the system when the AC power cord is pulled into the power supply.

The handle shall protect the operator from any burn hazard through the use of the Intel Corporation Industrial designed plastic handle or equivalent Intel approved material.

## 2.3 LED Marking and Identification

The power supply shall use a bi-color LED; Amber & Green. Below are table showing the LED states for each power supply operating state and the LED's wavelength characteristics. An example bi-color LED that meets the below characteristics is Kingbright L-3WGNW. as table below.

Refer to the Intel LED Wavelength and Intensity specification for more details.

Table 2.3 LED Characteristics

	Min λd Wavelength	Nominal λd Wavelength	Max λd Wavelength	Units
Green	562	565	568	nm
Amber	607	610	613	nm

Table 2 LED States Description

Power Supply Condition	LED State
Output ON and OK	GREEN
No AC power to all power supplies	OFF
AC present / Only 12VSB on (PS off) or PS in Smart on state	1Hz Blink GREEN
AC cord unplugged or AC power lost; with a second power supply in parallel still with AC input power.	AMBER
Power supply warning events where the power supply continues to operate; high temp, high power, high current, slow fan.	1Hz Blink Amber
Power supply critical event causing a shutdown; failure, OCP, OVP, Fan Fail	AMBER



台達電子工業股份有限公司  
DELTA ELECTRONICS, INC.

DESCRIPTION :

電氣規格 (Electrical Specification)

THESE DRAWINGS AND SPECIFICATIONS ARE THE PROPERTY OF DELTA ELECTRONICS, INC. AND SHALL NOT BE REPRODUCED OR USED AS THE BASIS FOR THE MANUFACTURE OR SELL OF APPARATUSES OR DEVICES WITHOUT PERMISSION.

MODEL NO. :

DPS-550AB-36 S

Date

Drawn

Design (EE)

Design (ME)

DOCUMENT NAME. :

REV.

10/18/'21

金雨霞

陳雨

賈曉東

ES-550AB-36 S

S03

## 2.4 Acoustic Requirements

The power supply shall incorporate variable speed fan(s). The declared sound power levels (LwAd) of the power supply unit (PSU) must meet the requirements shown in the table below. Sound power must be measured according to ECMA 74 (www.ecma-international.org) and reported according to ISO 9296.

## 2.5 Temperature Requirements

The power supply shall operate within all specified limits over the T<sub>op</sub> temperature range. All airflow shall pass through the power supply and not over the exterior surfaces of the power supply.

Table 2.5 Environmental Requirements

ITEM	DESCRIPTION	MIN	MAX	UNITS
T <sub>op</sub>	Operating temperature range	0	50	°C
T <sub>exit</sub>	Maximum exit air temperature		70	°C
T <sub>non-op</sub>	Non-operating temperature range	-40	70	°C
Altitude	Maximum operating altitude <sup>3</sup>		5000	m

## 2.6 System impedance

The power supply shall incorporate a dual rotor 40mm fan for self cooling in system with higher airflow impedances. The airflow direction shall be from the card edge connector side to the AC inlet side of the power supply. If needed, system shall be capable of supplying the airflow that is sufficient for power supply cooling when installed in different system with higher airflow impedance.

# 3 AC Input Requirements

## 3.1 Power Factor

The power supply must meet the power factor requirements stated in the Energy Star® Program Requirements for Computer Servers. These requirements are stated below.

Table 3.1 PFC Limits

Output power	10% load	20% load	50% load	100% load
Power factor	> 0.65	> 0.80	> 0.90	> 0.95

Tested at 230Vac, 50Hz and 60Hz and 115VAC, 60Hz

Tested according to Generalized Internal Power Supply Efficiency Testing Protocol Rev 6.4.3.

## 3.2 AC Inlet Connector

The AC input connector shall be an IEC 320 C-14 power inlet. This inlet is rated for 10A / 250VAC.

## 3.3 AC Input Voltage Specification

The power supply must operate within all specified limits over the following input voltage range. Harmonic distortion of up to 10% of the rated line voltage must not cause the power supply to go out of specified limits. Application of an input voltage below 85VAC shall not cause damage to the power supply, including a blown fuse.

Table 3.3.1 AC Input Voltage Range

PARAMETER	MIN	RATED	V <sub>MAX</sub>	Start up VAC	Power Off VAC
Voltage (110)	90 V <sub>rms</sub>	100-127 V <sub>rms</sub>	140 V <sub>rms</sub>	85VAC +/- 4VAC	74VAC +/- 5VAC
Voltage (220)	180 V <sub>rms</sub>	200-240 V <sub>rms</sub>	264 V <sub>rms</sub>		
Frequency	47 Hz	50/60	63 Hz		

<sup>1</sup> Maximum input current at low input voltage range shall be measured at 90VAC, at max load.

 <b>台達電子工業股份有限公司</b> <b>DELTA ELECTRONICS, INC.</b>				DESCRIPTION : 電氣規格 (Electrical Specification)	
THESE DRAWINGS AND SPECIFICATIONS ARE THE PROPERTY OF DELTA ELECTRONICS, INC. AND SHALL NOT BE REPRODUCED OR USED AS THE BASIS FOR THE MANUFACTURE OR SELL OF APPARATUSES OR DEVICES WITHOUT PERMISSION.				MODEL NO. : <b>DPS-550AB-36 S</b>	
Date	Drawn	Design (EE)	Design (ME)	DOCUMENT NAME. :	REV.
10/18/'21	金雨霞	陳雨	賈曉東	<b>ES-550AB-36 S</b>	<b>S03</b>



- 2 Maximum input current at high input voltage range shall be measured at 180VAC, at max load.
- 3 This requirement is not to be used for determining agency input current markings.
- 4 The power supply can support UPS input, the UPS must be applied within 10ms after loss of AC, at 70% of max load with single module, at max load with double module.

•Support 240VDC input

Table 3.3.2 DC Input Voltage Range

Parameter	Min	Nominal	Max
DC input voltage	180VDC	240VDC	300VDC

Note: Comply with CCC safety test requirement.

### 3.4 AC Line Isolation Requirements

The power supply shall meet all safety agency requirements for dielectric strength. Additionally, power supply vendor must provide Intel with written confirmation of dielectric withstand test which includes: voltage level, duration of test and identification detailing how each power supply is marked to indicate dielectric withstand test had been completed successfully. Transformers' isolation between primary and secondary windings must comply with the 3000Vac (4242Vdc) dielectric strength criteria. If the working voltage between primary and secondary dictates a higher dielectric strength test voltage the highest test voltage should be used. In addition the insulation system must comply with reinforced insulation per safety standard IEC 60950. Separation between the primary and secondary circuits, and primary to ground circuits, must comply with the IEC 60950 spacing requirements.

### 3.5 AC Line Dropout / Holdup

An AC line dropout is defined to be when the AC input drops to 0VAC at any phase of the AC line for any length of time. During an AC dropout the power supply must meet dynamic voltage regulation requirements. An AC line dropout of any duration shall not cause tripping of control signals or protection circuits. If the AC dropout lasts longer than the hold up time the power supply should recover and meet all turn on requirements. The power supply shall meet the AC dropout requirement over rated AC voltages and frequencies. A dropout of the AC line for any duration shall not cause damage to the power supply.

Table 3.5 AC line Holdup time Limit

Loading	Holdup time
70%	10msec

#### 3.5.1 AC Line 12VSB Holdup

The 12VSB output voltage should stay in regulation under its full load (static or dynamic) during an AC dropout of **70ms min** (=12VSB holdup time) whether the power supply is in ON or OFF state (PSON asserted or de-asserted).

### 3.6 AC Line Fuse

The power supply shall have one line fused in the **single line fuse** on the line (Hot) wire of the AC input. The line fusing shall be acceptable for all safety agency requirements. The input fuse shall be a slow blow type. AC inrush current shall not cause the AC line fuse to blow under any conditions. All protection circuits in the power supply shall not cause the AC fuse to blow unless a component in the power supply has failed. This includes DC output load short conditions.

### 3.7 AC Inrush

AC line inrush current shall not exceed **55A peak**, for up to one-quarter of the AC cycle, after which, the input current should be no more than the specified maximum input current. The peak inrush current shall be less than the ratings of its critical components (including input fuse, bulk rectifiers, and surge limiting device). The power supply must meet the inrush requirements for any rated AC voltage, during turn on at any phase of AC voltage, during a single cycle AC dropout condition as well as upon recovery after AC dropout of any duration, and over the specified temperature range (T<sub>op</sub>).

 <b>台達電子工業股份有限公司</b> <b>DELTA ELECTRONICS, INC.</b>				DESCRIPTION :	
				電氣規格 (Electrical Specification)	
THESE DRAWINGS AND SPECIFICATIONS ARE THE PROPERTY OF DELTA ELECTRONICS, INC. AND SHALL NOT BE REPRODUCED OR USED AS THE BASIS FOR THE MANUFACTURE OR SELL OF APPARATUSES OR DEVICES WITHOUT PERMISSION.				MODEL NO. :	
				DPS-550AB-36 S	
Date	Drawn	Design (EE)	Design (ME)	DOCUMENT NAME. :	REV.
10/18/'21	金雨霞	陳雨	賈曉東	ES-550AB-36 S	S03

### 3.8 AC Line Transient Specification

AC line transient conditions shall be defined as “sag” and “surge” conditions. “Sag” conditions are also commonly referred to as “brownout”, these conditions will be defined as the AC line voltage dropping below nominal voltage conditions. “Surge” will be defined to refer to conditions when the AC line voltage rises above nominal voltage. The power supply shall meet the requirements under the following AC line sag and surge conditions.

Table 3.8.1 AC Line Sag Transient Performance

AC Line Sag (10sec interval between each sagging)				
Duration	Sag	Operating AC Voltage	Line Frequency	Performance Criteria
0 to 1/2 AC cycle	95%	Nominal AC Voltage ranges	50/60Hz	No loss of function or performance
> 1 AC cycle	>30%	Nominal AC Voltage ranges	50/60Hz	Loss of function acceptable, self recoverable

Table 3.8.2 AC Line Surge Transient Performance

AC Line Surge				
Duration	Surge	Operating AC Voltage	Line Frequency	Performance Criteria
Continuous	10%	Nominal AC Voltages	50/60Hz	No loss of function or performance
0 to 1/2 AC cycle	30%	Mid-point of nominal AC Voltages	50/60Hz	No loss of function or performance

### 3.9 Susceptibility Requirements

The power supply shall meet the following electrical immunity requirements when connected to a cage with an external EMI filter which meets the criteria defined in the SSI document EPS Power Supply Specification.

Table 3.9 Performance Criteria

Level	Description
A	The apparatus shall continue to operate as intended. No degradation of performance.
B	The apparatus shall continue to operate as intended. No degradation of performance beyond spec limits.
C	Temporary loss of function is allowed provided the function is self-recoverable or can be restored by the operation of the controls.

### 3.10 Electrostatic Discharge Susceptibility

The power supply shall comply with the limits defined in EN 55024: 1998/A1: 2001/A2: 2003 using the IEC 61000-4-2: Edition 1.2: 2001-04 test standard and performance criteria B defined in Annex B of CISPR 24. Test condition: +/-8KV contact discharge; +/-15KV air discharge.

### 3.11 Fast Transient/Burst

The power supply shall comply with the limits defined in EN55024: 1998/A1: 2001/A2: 2003 using the IEC 61000-4-4: Second edition: 2004-07 test standard and performance criteria B defined in Annex B of CISPR 24. Test condition: min 1KV;

### 3.12 Radiated Immunity

The power supply shall comply with the limits defined in EN55024: 1998/A1: 2001/A2: 2003 using the IEC 61000-4-3: Edition 2.1: 2002-09 test standard and performance criteria A defined in Annex B of CISPR 24. Test condition: min 3V/m.

### 3.13 Surge Immunity (PLD)

The power supply shall be tested with the system for immunity to AC Unidirectional wave; 4kV line to ground and 2kV line to line, per EN 55024: 1998/A1: 2001/A2: 2003, EN 61000-4-5: Edition 1.1:2001-04 . The pass criteria include: No unsafe operation is allowed under any condition; all power supply output voltage levels to stay within proper spec levels; No change in operating state or loss of data during and after the test profile; No component damage under any condition.

 <b>台達電子工業股份有限公司</b> <b>DELTA ELECTRONICS, INC.</b>				DESCRIPTION : 電氣規格 (Electrical Specification)	
THESE DRAWINGS AND SPECIFICATIONS ARE THE PROPERTY OF DELTA ELECTRONICS, INC. AND SHALL NOT BE REPRODUCED OR USED AS THE BASIS FOR THE MANUFACTURE OR SELL OF APPARATUSES OR DEVICES WITHOUT PERMISSION.				MODEL NO. : <b>DPS-550AB-36 S</b>	
Date	Drawn	Design (EE)	Design (ME)	DOCUMENT NAME. :	REV.
10/18/'21	金雨霞	陳雨	賈曉東	<b>ES-550AB-36 S</b>	<b>S03</b>



Note: the power supply shall be tested to 4.2kV line to ground and 2.1kV line to line to check for design margin. The power supply shall comply with the limits defined in EN55024: 1998/A1: 2001/A2: 2003 using the IEC 61000-4-5: Edition 1.1:2001-04 test standard and performance criteria B defined in Annex B of CISPR 24.

### 3.14 Power Recovery

The power supply shall recover automatically after an AC power failure. AC power failure is defined to be any loss of AC power that exceeds the dropout criteria.

### 3.15 Voltage Interruptions

The power supply shall comply with the limits defined in EN55024: 1998/A1: 2001/A2: 2003 using the IEC 61000-4-11: Second Edition: 2004-03 test standard and performance criteria C defined in Annex B of CISPR 24.

## 4 Efficiency

The following table provides the required minimum efficiency level at various loading conditions. These are provided at three different load levels; 100%, 50%, 20%, and 10%. Output shall be load according to the proportional loading method defined by 80 Plus in Generalized Internal Power Supply Efficiency Testing Protocol Rev 6.4.3. This is posted at <http://efficientpowersupplies.epri.com/methods.asp>

Table 4 Platinum Efficiency Requirement

Loading	100% of maximum	50% of maximum	20% of maximum	10% of maximum
Minimum Efficiency	91%	94%	90%	82%
Power Factor		0.95		

Note:

- 1.The fan losses are not including in the efficiency calculation and measurements.
- 2.Tested at 230Vac/50Hz.

## 5 DC Output Specification

### 5.1 Signal Description

Table 5.1 Signal Description

Signal	Description
+12V	+12V output
+12VSB	+12V standby output
GND	0V output ground
12LS	+12V load share bus
+12VRS	+12V remote sense
RETURN_S	0V output ground sense
PWOK	Power ok output
PSON	Power on input
SCL	SMBus Clock
SDA	SMBus Data
A0	SMBus address bit 0
A1	SMBus address bit 1
SMART_ON	Control signal for smart redundancy(power save)
PRESENT	Power supply present
SMBAlert	I2C alert signal (interrupt)
N.C	No connect



台達電子工業股份有限公司  
DELTA ELECTRONICS, INC.

DESCRIPTION :  
電氣規格 (Electrical Specification)

THESE DRAWINGS AND SPECIFICATIONS ARE THE PROPERTY OF DELTA ELECTRONICS, INC. AND SHALL NOT BE REPRODUCED OR USED AS THE BASIS FOR THE MANUFACTURE OR SELL OF APPARATUSES OR DEVICES WITHOUT PERMISSION.

MODEL NO. :  
DPS-550AB-36 S

Date	Drawn	Design (EE)	Design (ME)	DOCUMENT NAME. :	REV.
10/18/'21	金雨霞	陳雨	賈曉東	ES-550AB-36 S	S03

## 5.2 Output Power / Currents

The following tables defines the minimum power and current ratings. The power supply must meet both static and dynamic voltage regulation requirements for all conditions.

Table 5.2 Minimum Load Ratings

Parameter	VAC	Min	Max	20sec Peak <sup>2</sup>
12V main	100-240	0.0 A	45 A	50 A
12Vstby <sup>1</sup>		0.0 A	2.1 A	2.4 A
Total power			550 W	

Notes:.

- 1) After normal operation 12Vstby must provide 4.0A with two power supplies in parallel. The Fan may work when 12Vstby current >1.5A;
- 2) The peak load on 12V output shall not exceed 50 A, the keep time of peak load shall not exceed 20S;
- 3) Maximum continuous output power shall not exceed 550W.

## 5.3 Standby Output

The 12VSB output shall be present when an AC input greater than the power supply turn on voltage is applied. And two PSU modules should be able to support 4A standby current. The 4A loading shall be gradually increased after powering on two power supplies.

## 5.4 Voltage Regulation

The power supply output voltages must stay within the following voltage limits when operating at steady state and dynamic loading conditions. These limits include the peak-peak ripple/noise. These shall be measured at the output connectors.

Table 5.4 Voltage Regulation Limits

PARAMETER	TOLERANCE	MIN	NOM	MAX	UNITS
+12V	- 5% / +5%	+11.40	+12.00	+12.60	V <sub>rms</sub>
+12V stby	- 5% / +5%	+11.40	+12.00	+12.60	V <sub>rms</sub>

## 5.5 Dynamic Loading

The output voltages shall remain within limits specified for the step loading and capacitive loading specified in the table below. The load transient repetition rate shall be tested between 50Hz and 5kHz at duty cycles ranging from 10%-90%. The load transient repetition rate is only a test specification. The  $\Delta$  step load may occur anywhere within the MIN load to the MAX load conditions.

Table 5.5 Transient Load Requirements

Output	$\Delta$ Step Load Size (See note 2)	Load Slew Rate	Test capacitive Load
+12VSB	1.0A	0.5 A/ $\mu$ sec	2200 $\mu$ F
+12V	60% of max load	0.5 A/ $\mu$ sec	2200 $\mu$ F

Note: For dynamic condition +12V min loading is 1A . Min loading 1~2A spec is +/-10%,  
Min loading >2A spec is +/-5%

 <b>台達電子工業股份有限公司</b> <b>DELTA ELECTRONICS, INC.</b>				DESCRIPTION :	
				電氣規格 (Electrical Specification)	
THESE DRAWINGS AND SPECIFICATIONS ARE THE PROPERTY OF DELTA ELECTRONICS, INC. AND SHALL NOT BE REPRODUCED OR USED AS THE BASIS FOR THE MANUFACTURE OR SELL OF APPARATUSES OR DEVICES WITHOUT PERMISSION.				MODEL NO. :	
				DPS-550AB-36 S	
Date	Drawn	Design (EE)	Design (ME)	DOCUMENT NAME. :	REV.
10/18/'21	金雨霞	陳雨	賈曉東	ES-550AB-36 S	S03

## 5.6 Capacitive Loading

The power supply shall be stable and meet all requirements with the following capacitive loading ranges.

Table 5.6 Capacitive Loading Conditions

Output	MIN	MAX	Units
+12VSB	20	3100	μF
+12V	500	25000	μF

## 5.7 Grounding

The output ground of the pins of the power supply provides the output power return path. The output connector ground pins shall be connected to the safety ground (power supply enclosure). This grounding should be well designed to ensure passing the max allowed Common Mode Noise levels.

The power supply shall be provided with a reliable protective earth ground. All secondary circuits shall be connected to protective earth ground. Resistance of the ground returns to chassis shall not exceed 1.0 mΩ. This path may be used to carry DC current.

## 5.8 Closed loop stability

The power supply shall be unconditionally stable under all line/load/transient load conditions including capacitive load ranges specified in Section 5.6. A minimum of: **45 degrees phase margin** and **-10dB-gain margin** is required. The power supply manufacturer shall provide proof of the unit's closed-loop stability with local sensing through the submission of Bode plots. Closed-loop stability must be ensured at the maximum and minimum loads as applicable.

## 5.9 Residual Voltage Immunity in Standby mode

The power supply should be immune to any residual voltage placed on its outputs (Typically a leakage voltage through the system from standby output) up to **500mV**. There shall be no additional heat generated, nor stressing of any internal components with this voltage applied to any individual or all outputs simultaneously. It also should not trip the protection circuits during turn on.

The residual voltage at the power supply outputs for no load condition shall not exceed **100mV** when AC voltage is applied and the PSON# signal is de-asserted.

## 5.10 Common Mode Noise

The Common Mode noise on any output shall not exceed **350mV pk-pk** over the frequency band of 10Hz to 20MHz.

1. The measurement shall be made across a 100Ω resistor between each of DC outputs and ground, including ground at the DC power connector and chassis ground (power subsystem enclosure).
2. The test set-up shall use a FET probe such as Tektronix model P6046 or equivalent.

## 5.11 Soft Starting

The Power Supply shall contain control circuit which provides monotonic soft start for its outputs without overstress of the AC line or any power supply components at any specified AC line or load conditions.

## 5.12 Zero Load Stability Requirements

When the power subsystem operates in a no load condition, it does not need to meet the output regulation specification, but it must operate without any tripping of over-voltage or other fault circuitry. When the power subsystem is subsequently loaded, it must begin to regulate and source current without fault.

## 5.13 Hot Swap Requirements

Hot swapping a power supply is the process of inserting and extracting a power supply from an operating power system. During this process the output voltages shall remain within the limits with the capacitive load specified. The

 台達電子工業股份有限公司 DELTA ELECTRONICS, INC.				DESCRIPTION : 電氣規格 (Electrical Specification)	
THESE DRAWINGS AND SPECIFICATIONS ARE THE PROPERTY OF DELTA ELECTRONICS, INC. AND SHALL NOT BE REPRODUCED OR USED AS THE BASIS FOR THE MANUFACTURE OR SELL OF APPARATUSES OR DEVICES WITHOUT PERMISSION.				MODEL NO. : DPS-550AB-36 S	
Date	Drawn	Design (EE)	Design (ME)	DOCUMENT NAME. :	REV.
10/18/'21	金雨霞	陳雨	賈曉東	ES-550AB-36 S	S03

hot swap test must be conducted when the system is operating under static, dynamic, and zero loading conditions. The power supply shall use a latching mechanism to prevent insertion and extraction of the power supply when the AC power cord is inserted into the power supply.

### 5.14 Forced Load Sharing

The +12V output will have active load sharing. The output will share within 10% at full load. The failure of a power supply should not affect the load sharing or output voltages of the other supplies still operating. The supplies must be able to load share in parallel and operate in a hot-swap / redundant 1+1 configurations. The 12VSB output is not required to actively share current between power supplies (passive sharing). The 12VSB output of the power supplies are connected together in the system so that a failure or hot swap of a redundant power supply does not cause these outputs to go out of regulation in the system.

### 5.15 Ripple / Noise

At room temperature, The maximum allowed ripple/noise output of the power supply is defined in the table below. This is measured over a bandwidth of 10Hz to 20MHz at the power supply output connectors. A 10µF tantalum capacitor in parallel with a 0.1µF ceramic capacitor is placed at the point of measurement.

Table 5.15: Ripples and Noise

+12V main	+12VSB
120mVp-p	120mVp-p

- Adding minimum capacitive Loading (20uF) in +12VSB output, and capacitance of 3300uF in +12V output.

The test set-up shall be as shown below.

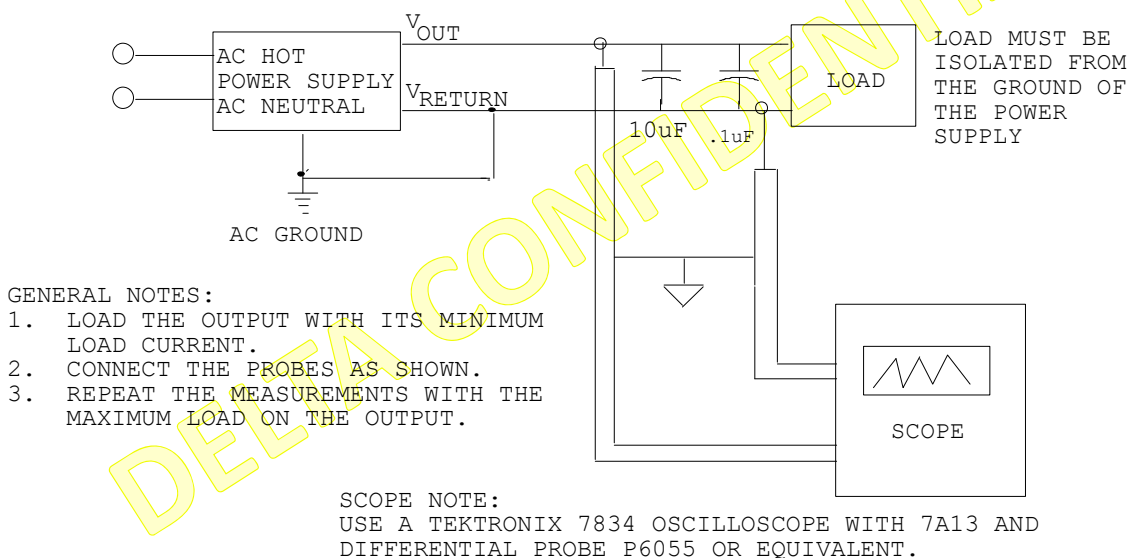



Figure 5.15 Differential Noise test setup

Note: When performing this test, the probe clips and capacitors should be located close to the load.

### 5.16 Timing Requirements

These are the timing requirements for the power supply operation. The output voltages must rise from 10% to within regulation limits ( $T_{vout\_rise}$ ) within 2 to 70ms. For 12VSB, it is allowed to rise from 1.0 to 25ms. **All outputs**

 <b>台達電子工業股份有限公司</b> <b>DELTA ELECTRONICS, INC.</b>				DESCRIPTION : 電氣規格 (Electrical Specification)	
THESE DRAWINGS AND SPECIFICATIONS ARE THE PROPERTY OF DELTA ELECTRONICS, INC. AND SHALL NOT BE REPRODUCED OR USED AS THE BASIS FOR THE MANUFACTURE OR SELL OF APPARATUSSES OR DEVICES WITHOUT PERMISSION.				MODEL NO. : <b>DPS-550AB-36 S</b>	
Date	Drawn	Design (EE)	Design (ME)	DOCUMENT NAME. :	REV.
10/18/'21	金雨霞	陳雨	賈曉東	<b>ES-550AB-36 S</b>	<b>S03</b>

**must rise monotonically.** Table below shows the timing requirements for the power supply being turned on and off via the AC input, with PSON held low and the PSON signal, with the AC input applied.

Table 5.16 Timing Requirements

ITEM	DESCRIPTION	MIN	MAX	UNITS
$T_{vout\_rise}$	Output voltage rise time	2 *	70 *	ms
$T_{sb\_on\_delay}$	Delay from AC being applied to 12VSB being within regulation.		1500	ms
$T_{ac\_on\_delay}$	Delay from AC being applied to all output voltages being within regulation.		3000	ms
$T_{vout\_holdup}$	Time 12V <sub>I</sub> output voltage stay within regulation after loss of AC (At 70% Full load).	13		ms
$T_{pwok\_holdup}$	Delay from loss of AC to de-assertion of PWOK (At 70% Full load).	12		ms
$T_{pson\_on\_delay}$	Delay from PSON# active to output voltages within regulation limits.	5	400	ms
$T_{pson\_pwok}$	Delay from PSON# deactivate to PWOK being de-asserted.		5	ms
$T_{pwok\_on}$	Delay from output voltages within regulation limits to PWOK asserted at turn on.	100	500	ms
$T_{pwok\_off}$	Delay from PWOK de-asserted to output voltages dropping out of regulation limits.	1		ms
$T_{pwok\_low}$	Duration of PWOK being in the de-asserted state during an off/on cycle using AC or the PSON signal.	100		ms
$T_{sb\_vout}$	Delay from 12VSB being in regulation to O/Ps being in regulation at AC turn on.	50	1000	ms
$T_{12VSB\_holdup}$	Time the 12VSB output voltage stays within regulation after loss of AC.	70		ms

\* The 12VSB output voltage rise time shall be from 1.0ms to 25ms

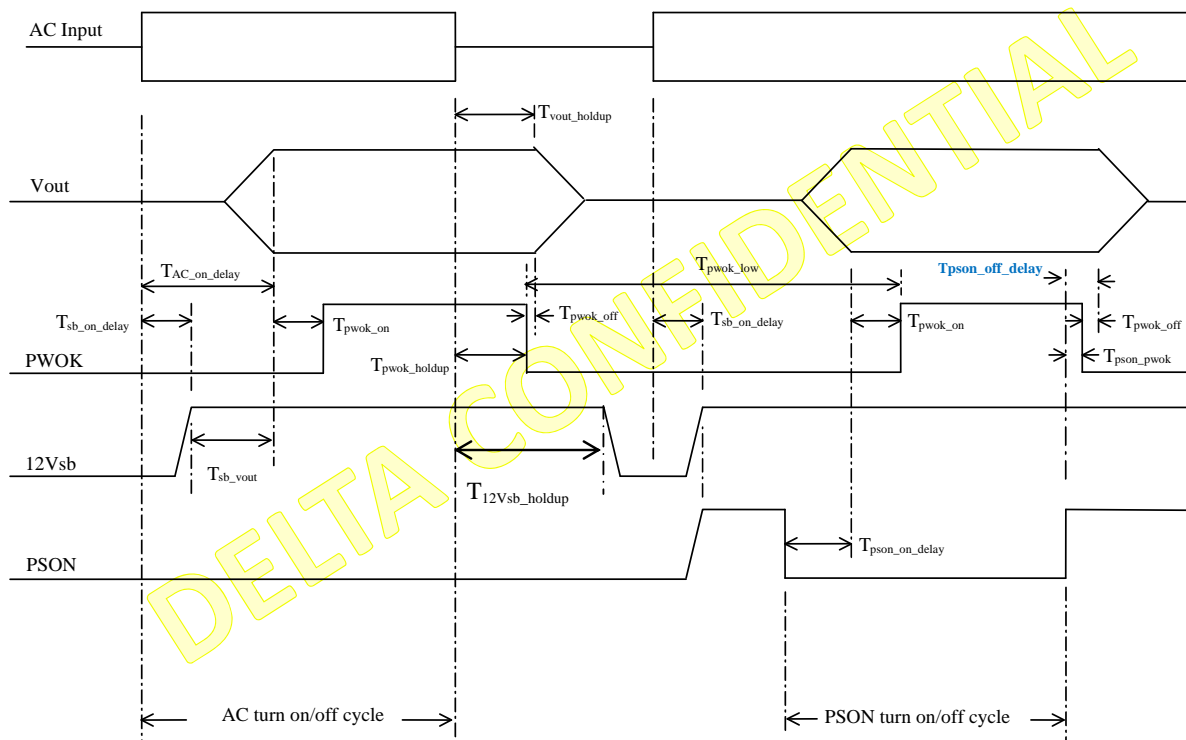



Figure 5.16 Turn On/Off Timing (Power Supply Signals)

 <b>台達電子工業股份有限公司</b> <b>DELTA ELECTRONICS, INC.</b>				DESCRIPTION : 電氣規格 (Electrical Specification)	
THESE DRAWINGS AND SPECIFICATIONS ARE THE PROPERTY OF DELTA ELECTRONICS, INC. AND SHALL NOT BE REPRODUCED OR USED AS THE BASIS FOR THE MANUFACTURE OR SELL OF APPARATUSSES OR DEVICES WITHOUT PERMISSION.				MODEL NO. : <b>DPS-550AB-36 S</b>	
Date	Drawn	Design (EE)	Design (ME)	DOCUMENT NAME. :	REV.
10/18/'21	金雨霞	陳雨	賈曉東	ES-550AB-36 S	S03

## 6 Protection Circuits

Protection circuits inside the power supply shall cause only the power supply's main outputs to shutdown. If the power supply latches off due to a protection circuit tripping, an AC cycle OFF for 15sec and a PSON# cycle HIGH for 1sec shall be able to reset the power supply.

### 6.1 Current Limit (OCP)

The power supply shall have current limit to prevent the outputs from exceeding the values shown in table below. If the current limits are exceeded the power supply shall shutdown and latch off. The latch will be cleared by toggling the PSON# signal or by an AC power interruption. The power supply shall not be damaged from repeated power cycling in this condition. 12VSB will be auto-recovered after removing OCP limit.

Table 6.1 Over Current Protection

Output VOLTAGE	Input voltage range	OVER CURRENT LIMITS
+12V	90 – 264VAC	52Amin, 60Amax
	Trip delay	50msec min
12VSB	90 – 264VAC	2.5A min, 6A max

### 6.2 Over Voltage Protection (OVP)

The power supply over voltage protection shall be locally sensed. The power supply shall shutdown and latch off after an over voltage condition occurs. This latch shall be cleared by toggling the PSON# signal or by an AC power interruption. The values are measured at the output of the power supply's connectors. The voltage shall never exceed the maximum levels when measured at the power connectors of the power supply connector during any single point of fail. The voltage shall never trip any lower than the minimum levels when measured at the power connector. 12VSB will be auto-recovered after removing OVP limit.

Table 6.2 Over Voltage Protection (OVP) Limits

Output Voltage	MIN (V)	MAX (V)
+12V	13.5	15
+12VSB	13.5	15

### 6.3 Over Temperature Protection (OTP)

The power supply will be protected against over temperature conditions caused by loss of fan cooling or excessive ambient temperature. In an OTP condition the PSU will shutdown. When the power supply temperature drops to within specified limits, the power supply shall restore power automatically, while the 12VSB remains always on. The OTP circuit must have built in margin such that the power supply will not oscillate on and off due to temperature recovering condition. The OTP trip level shall have a minimum of 4°C of ambient temperature margin.

### 6.4 Short Circuit Protection (SCP)

The power supply shall shut down when any output is short circuit (impedance less than 0.1ohm) with DC return,

- 1) The power supply shall be no physical damage when 12V, 12VSB output is shorted to its DC return.
- 2) The main output (12V) shall be Latch off when the short condition at 12V is removed, and the latch can only be cleared by an AC input reset or PS\_OFF reset.
- 3) The power supply shall be Auto Restart when the short condition at 12VSB is removed.

 <b>台達電子工業股份有限公司</b> <b>DELTA ELECTRONICS, INC.</b>				DESCRIPTION :	
				電氣規格 (Electrical Specification)	
THESE DRAWINGS AND SPECIFICATIONS ARE THE PROPERTY OF DELTA ELECTRONICS, INC. AND SHALL NOT BE REPRODUCED OR USED AS THE BASIS FOR THE MANUFACTURE OR SELL OF APPARATUSES OR DEVICES WITHOUT PERMISSION.				MODEL NO. :	
				DPS-550AB-36 S	
Date	Drawn	Design (EE)	Design (ME)	DOCUMENT NAME. :	REV.
10/18/'21	金雨霞	陳雨	賈曉東	ES-550AB-36 S	S03



## 7 Control and Indicator Functions

The following sections define the input and output signals from the power supply. Signals that can be defined as low true use the following convention: *Signal#* = low true

### 7.1 PSON# Input Signal

The PSON# signal is required to remotely turn on/off the power supply. PSON# is an active low signal that turns on the +12V power rail. When this signal is not pulled low by the system, or left open, the outputs (except the +12VSB) turn off. This signal is pulled to a standby voltage by a pull-up resistor internal to the power supply. Refer to the following table for the timing diagram.

Table 7.1 PSON# Signal Characteristic

<b>Signal Type</b>	Accepts an open collector/drain input from the system. Pull-up to VSB located in power supply.	
<b>PSON# = Low</b>	<b>ON</b>	
<b>PSON# = High or Open</b>	<b>OFF</b>	
	<b>MIN</b>	<b>MAX</b>
<b>Logic level low (power supply ON)</b>	<b>0V</b>	<b>0.8V</b>
<b>Logic level high (power supply OFF)</b>	<b>2.0V</b>	<b>3.46V</b>
<b>Source current, <math>V_{pson} = \text{low}</math></b>	<b>4mA</b>	
<b>Power up delay: <math>T_{pson\_on\_delay}</math></b>	<b>5msec</b>	<b>400msec</b>
<b>PWOK delay: <math>T_{pson\_pwok}</math></b>	<b>5msec</b>	

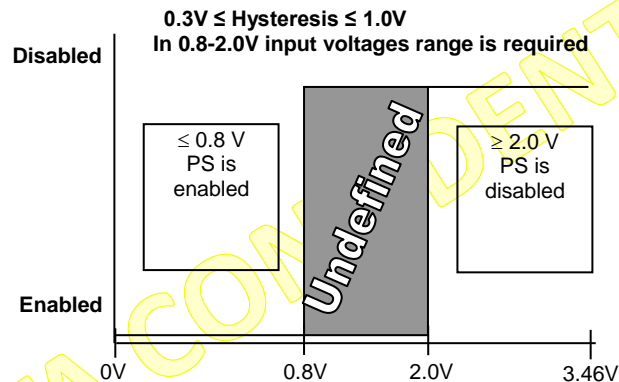

Figure 7.1 PSON# Required Signal Characteristic.

### 7.2 PWOK (Power OK) Output Signal

PWOK is a power OK signal and will be pulled HIGH by the power supply to indicate that all the outputs are within the regulation limits of the power supply. When any output voltage falls below regulation limits or when AC power has been removed for a time sufficiently long so that power supply operation is no longer guaranteed, PWOK will be de-asserted to a LOW state. See the following table for a representation of the timing characteristics of PWOK. The start of the PWOK delay time shall inhibited as long as any power supply output is in current limit.

 <b>台達電子工業股份有限公司</b> <b>DELTA ELECTRONICS, INC.</b>				DESCRIPTION :	
				電氣規格 (Electrical Specification)	
THESE DRAWINGS AND SPECIFICATIONS ARE THE PROPERTY OF DELTA ELECTRONICS, INC. AND SHALL NOT BE REPRODUCED OR USED AS THE BASIS FOR THE MANUFACTURE OR SELL OF APPARATUSES OR DEVICES WITHOUT PERMISSION.				MODEL NO. :	
				DPS-550AB-36 S	
Date	Drawn	Design (EE)	Design (ME)	DOCUMENT NAME. :	REV.
10/18/'21	金雨霞	陳雨	賈曉東	ES-550AB-36 S	S03

Table 7.2 PWOK Signal Characteristics

Signal Type	Open collector/drain output from power supply. Pull-up to VSB located in the power supply.	
PWOK = High	Power OK	
PWOK = Low	Power Not OK	
	MIN	MAX
Logic level low voltage, Isink=400uA	0V	0.4V
Logic level high voltage, Isource=200µA	2.4V	3.46V
Sink current, PWOK = low		400uA
Source current, PWOK = high		2mA
PWOK delay: T <sub>pwok_on</sub>	100ms	500ms
PWOK rise and fall time		100µsec
Power down delay: T <sub>pwok_off</sub>	1ms	

A recommended implementation of the Power Ok circuits is shown below.

Note: the Power Ok circuits should be compatible with 5V pull up resistor (>10k) and 3.3V pull up resistor (>6.8k)

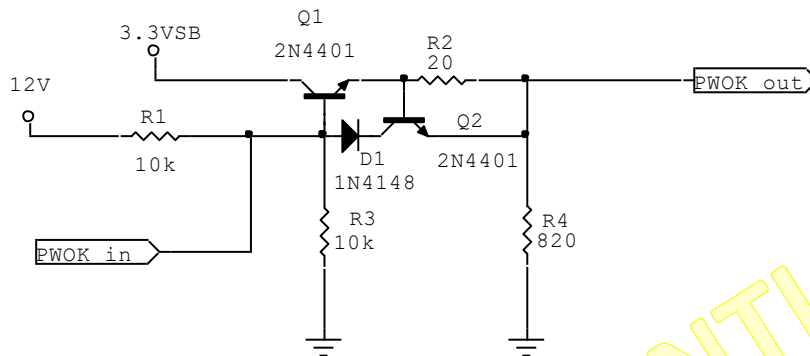

Figure 7.2 Power Ok recommended circuit

### 7.3 SMBAlert# Signal

This signal indicates that the power supply is experiencing a problem that the user should investigate. This shall be asserted due to Critical events or Warning events. The signal shall activate in the case of critical component temperature reached a warning threshold, general failure, over-current, over-voltage, under-voltage, failed fan. This signal may also indicate the power supply is reaching its end of life or is operating in an environment exceeding the specified limits.

This signal is to be asserted in parallel with LED turning solid Amber or blink Amber.

Table 7.3 SMBAlert# Signal Characteristics

Signal Type (Active Low)	Open collector / drain output from power supply. Pull-up to VSB located in system.	
Alert# = High	OK	
Alert# = Low	Power Alert to system	
	MIN	MAX
Logic level low voltage, Isink=4 mA	0 V	0.4 V
Logic level high voltage, Isource=50 µA	2.4 V	3.46 V
Sink current, Alert# = low		4 mA
Source current, Alert# = high		50 µA
Alert# rise and fall time		100 µs



台達電子工業股份有限公司  
DELTA ELECTRONICS, INC.

DESCRIPTION :

電氣規格 (Electrical Specification)

THESE DRAWINGS AND SPECIFICATIONS ARE THE PROPERTY OF DELTA ELECTRONICS, INC. AND SHALL NOT BE REPRODUCED OR USED AS THE BASIS FOR THE MANUFACTURE OR SELL OF APPARATUSES OR DEVICES WITHOUT PERMISSION.

MODEL NO. :

DPS-550AB-36 S

Date

Drawn

Design (EE)

Design (ME)

DOCUMENT NAME. :

REV.

10/18/'21

金雨霞

陳雨

賈曉東

ES-550AB-36 S

S03

## 8 Environmental Requirements

### 8.1 Temperature

See section 2.5 for operating requirements.

Non-operating Ambient: -40°C to +70°C (Maximum rate of change of 20°C/hour)

### 8.2 Humidity

Operating: To 85% relative humidity (non-condensing)

Non-Operating: To 95% relative humidity (non-condensing)

NOTE: 95% relative humidity is achieved with a dry bulb temperature of 55°C and a wet bulb temperature of 54°C.

### 8.3 Altitude

Operating: to 5000 m

Non-operating: to 15200 m

### 8.4 Mechanical Shock

Non-operating: 50 G Trapezoidal Wave, Velocity change = 170 in. / sec.

Three drops in each of six directions are applied to each of the samples.

### 8.5 Random Vibration

Non-operating

Sine sweep:

5Hz to 500Hz @ 0.5gRMS at 0.5 octave/min; dwell 15 min at each of 3 resonant points;

Random profile:

5Hz @ 0.01g<sup>2</sup>/Hz to 20Hz @ 0.02g<sup>2</sup>/Hz (slope up); 20Hz to 500Hz @ 0.02g<sup>2</sup>/Hz (flat);

Input acceleration = 3.13gRMS; 10 min. per axis for 3 axis on all samples

### 8.6 Thermal Shock (Shipping)

Non-operating: -40°C to +70°C, 50 cycles, 30 °C /min. transition time 15°C /min., duration of exposure to temperature extremes for each half cycle shall be 30 minutes.

## 9 FRU Requirements

### 9.1 FRU Data

The FRU data format shall be compliant with the *IPMI ver.1.0 (per rev.1.1 from Sept.25, 1999)* specification. The current version of these specifications is available at <http://developer.intel.com/design/servers/ipmi/spec.htm>. The following is the exact listing of the EEPROM content. During testing this listing shall be followed and verified.

### 9.2 FRU Device Protocol

The FRU device will implement the same protocols as the commonly used AT24C02 device, including the Byte Read, Sequential Read, Byte Write, and Page Read protocols.

 台達電子工業股份有限公司 DELTA ELECTRONICS, INC.				DESCRIPTION : 電氣規格 (Electrical Specification)	
THESE DRAWINGS AND SPECIFICATIONS ARE THE PROPERTY OF DELTA ELECTRONICS, INC. AND SHALL NOT BE REPRODUCED OR USED AS THE BASIS FOR THE MANUFACTURE OR SELL OF APPARATUSES OR DEVICES WITHOUT PERMISSION.				MODEL NO. : DPS-550AB-36 S	
Date	Drawn	Design (EE)	Design (ME)	DOCUMENT NAME. :	REV.
10/18/'21	金雨霞	陳雨	賈曉東	ES-550AB-36 S	S03

### 9.2.1 FRU Data Format

The information to be contained in the FRU device is shown in the following table.

**Table 9.2.1 FRU data format**

Area Type	Description
Common Header	As defined by the FRU document
Internal Use Area	Not required, do not reserve
Chassis Info Area	Not applicable, do not reserve
Board Info Area	Not applicable, do not reserve
Product Info Area	As defined by the IPMI FRU document. Product information shall be defined as follows:
<b>Field Name</b>	<b>Field Description</b>
Manufacturer Name	{Formal name of manufacturer}
Product Name	{Manufacturer's model number}
Product part/model number	Customer part number
Product Version	Customer current revision
Product Serial Number	{Defined at time of manufacture}
Asset Tag	{Not used, code is zero length byte}
FRU File ID	{Not required}
PAD Bytes	{Added as necessary to allow for 8-byte offset to next area}
Multi-Record Area	As defined by the IPMI FRU document. The following record types shall be used on this power supply: Power Supply Information (Record Type 0x00) DC Output (Record Type 0x01) No other record types are required for the power supply. Multi-Record information shall be defined as follows:
<b>Field Name (PS Info)</b>	<b>Field Information Definition</b>
Overall Capacity (watts)	550
Peak VA	625.2
Inrush current (A)	55
Inrush interval (msec)	5
Low end input voltage range 1	90
High end input voltage range 1	140
Low end input voltage range 2	180
High end input voltage range 2	264
A/C dropout total. (msec)	10
Binary flags	Set for: Hot Swap support, Auto switch, and PFC
Peak Wattage	Set for: 625.2 Watts
Combined wattage	None
Predictive fail tach support	Supported
Field Name (Output)	Field Description: Two outputs are to be defined from #1 to #2, as follows: +12V and +12VSB.
Output Information	Set for: Standby on +12VSB, No Standby on all others.
All other output fields	Format per IPMI specification, using parameters in this specification.

## 10 Common Requirements for CRPS

There are a set of common features that are required for all CRPS power supplies; PMBus, CLST, Smart, Smart ON, In-system FW Update, Black Box, and Compatibility Check. Refer to CRPS Common Requirements specification revision 1.2 for requirements on these features.

 <b>台達電子工業股份有限公司</b> <b>DELTA ELECTRONICS, INC.</b>				DESCRIPTION :	
				電氣規格 (Electrical Specification)	
THESE DRAWINGS AND SPECIFICATIONS ARE THE PROPERTY OF DELTA ELECTRONICS, INC. AND SHALL NOT BE REPRODUCED OR USED AS THE BASIS FOR THE MANUFACTURE OR SELL OF APPARATUSES OR DEVICES WITHOUT PERMISSION.				MODEL NO. :	
				DPS-550AB-36 S	
Date	Drawn	Design (EE)	Design (ME)	DOCUMENT NAME. :	REV.
10/18/'21	金雨霞	陳雨	賈曉東	ES-550AB-36 S	S03

# 11 Documentation

## 11.1 Thermal Evaluation

The power supply vendor will conduct a thermal evaluation of the power supply. This evaluation shall be completed at all full rated load conditions, with the AC line voltage margined, per typical safety agency test requirements (i.e. -10% and +6%). The power supply will be operated at maximum ambient temperature during this series of tests.

Additionally, a thermal test of the standby voltage supply shall be implemented, under the same conditions, with the power supply in the off condition, since the standby power supply typically relies on natural convection cooling when the power system is in the off condition.

A thermal test with PSU installed in system chassis and with dummy load connected to outside the chassis will also be performed.

The components tested should include all safety-related components such as the transformers, bulk capacitors, the printed circuit board, etc. Additional components that are key to the reliability of the power supply shall be measured. These include but are not limited to the switching transistors, bridges, diodes, etc.

The power supply vendor will provide a report detailing the test conditions, components measured, manufacturers maximum temperature, safety agency temperature limit (as applicable), and design goal maximum temperature (design goal temperature are for meeting the required MTBF of the power supply).

Unless otherwise wavered or approved by Intel, the design goal temperatures are also subject to reliability goals detailed in 11.1 Component De-rating

## 11.2 Safety Agency Test Results

As outlined in Section 12.0, Product Regulatory Requirements, the power supply manufacturer will provide complete copies of all safety agency reports, and data submitted to the safety agencies. A copy of any additional data gathered but not included in the data submitted to the safety agencies shall also be provided.

These tests shall be completed at all full rated load conditions, with the AC line voltage margined, per typical safety agency test requirements (i.e. -10% and +6%). The power supply will be operated at maximum ambient temperature during this series of tests.

DELTA CONFIDENTIAL

 台達電子工業股份有限公司 DELTA ELECTRONICS, INC.				DESCRIPTION : 電氣規格 (Electrical Specification)	
THESE DRAWINGS AND SPECIFICATIONS ARE THE PROPERTY OF DELTA ELECTRONICS, INC. AND SHALL NOT BE REPRODUCED OR USED AS THE BASIS FOR THE MANUFACTURE OR SELL OF APPARATUSES OR DEVICES WITHOUT PERMISSION.				MODEL NO. : DPS-550AB-36 S	
Date	Drawn	Design (EE)	Design (ME)	DOCUMENT NAME. :	REV.
10/18/'21	金雨霞	陳雨	賈曉東	ES-550AB-36 S	S03

## 12 Reliability / Warranty / Service

### 12.1 Life Requirement

The power supply shall support **5 year** calculated life with a 90% confidence under the following conditions:

- 100-240VAC input
- 50C inlet temperature
- at 80% load.

\*remove the original "investigative" life time requirement.

### 12.2 Mean Time between Failures (MTBF)

The power supply shall have a minimum MTBF at continuous operation of

1. 100,000 hours at 75% load and 40°C, as **calculated** by Bell core RPP, or
2. 250,000 hours **demonstrated** at 75% load and 40°C.

### 12.3 Warranty Period

Three (3) years.

### 12.4 Serviceability

No troubleshooting by maintenance personnel is to be performed. Only unit replacement will be done in the field

## 13 Product Regulatory Requirements

**Intended Application** – This product was evaluated as Information Technology Equipment (ITE), which may be installed in offices, schools, computer rooms, and similar commercial type locations. The suitability of this product for other product categories and environments (such as: medical, industrial, telecommunications, NEBS, residential, alarm systems, test equipment, etc.), other than an ITE application, may require further evaluation.

### 13.1 Product Safety Compliance

UL60950-1/CSA 60950-1 (USA / Canada)

EN60950-1 (Europe)

IEC60950-1 (International)

CB Certificate & Report, IEC60950-1 (report to include all country national deviations)

Nordics – EMKO-TSE (74-SEC) 207/94

CE - Low Voltage Directive 2006/95/EC (Europe)

GB4943- CNCA Certification (China)

**IEC62368-1**

### 13.2 Product EMC Compliance – Class A Compliance

Note: The product is required to comply with Class A emission requirements as the end system that it is configured into is intended for a commercial environment and market place. Power supply is to have minimum of 3db margin to Class A Limits to support Intel's margin requirements. (For conduct EMI, can have a minimum of 3db margin to class A limits.)

FCC /ICES-003 - Emissions (USA/Canada) Verification

CISPR 22 – Emissions (International)

EN55022 - Emissions (Europe)

EN55024 - Immunity (Europe)

 <b>台達電子工業股份有限公司</b> <b>DELTA ELECTRONICS, INC.</b>				DESCRIPTION :	
				電氣規格 (Electrical Specification)	
THESE DRAWINGS AND SPECIFICATIONS ARE THE PROPERTY OF DELTA ELECTRONICS, INC. AND SHALL NOT BE REPRODUCED OR USED AS THE BASIS FOR THE MANUFACTURE OR SELL OF APPARATUSES OR DEVICES WITHOUT PERMISSION.				MODEL NO. :	
				DPS-550AB-36 S	
Date	Drawn	Design (EE)	Design (ME)	DOCUMENT NAME. :	REV.
10/18/'21	金雨霞	陳雨	賈曉東	ES-550AB-36 S	S03



- EN61000-4-2 Electrostatic Discharge
- EN61000-4-3 Radiated RFI Immunity
- EN61000-4-4 Electrical Fast Transients
- EN61000-4-5 Electrical Surge
- EN61000-4-6 RF Conducted
- EN61000-4-8 Power Frequency Magnetic Fields
- EN61000-4-11 Voltage Dips and Interruptions

\*EN61000-3-2 - Harmonics (Europe)

\*EN61000-3-3 - Voltage Flicker (Europe)

CE – EMC Directive 89/336/EEC (Europe)

JEIDA (Japan)

AS/NZS CISPR 22 (Australia / New Zealand)

GB 9254 – (EMC) Certification (China)

GB 17625.1 - (Harmonics) CNCA Certification (China)

*\*Refer to detailed Harmonic Requirements and Table 23*

### 13.3 Certifications / Registrations / Declarations

UL Certification (US/Canada)

CB Certificate & Report

CE Declaration of Conformity (CENELEC Europe)

CNCA Certification (China)

BSMI Certification (Taiwan)

KC Certification(South Korea)

CU/EAC Certificate(Russia)

TUV Certification(Germany)

Notes:

- a) Certification shall be done to the most recent standard editions.
- b) To support ALPHA or BETA development power supply shipments, at least one 3<sup>rd</sup> party certification is required (e.g. NEMKO, UL, etc.).
- c) Power Supply Vendor requires providing copy of each certification.

### 13.4 Component Regulation Requirements

- A. All Fans shall have the minimum certifications: UL and TUV or VDE
- B. All current limiting devices shall have UL and TUV or VDE certifications and shall be suitable rated for the application where the device in its application complies with IEC60950.
- C. All printed wiring boards shall be rated UL94V-0 and be sourced from a UL approved printed wiring board manufacturer
- D. All connectors shall be UL recognized and have a UL flame rating of UL94V-0
- E. All wiring harnesses shall be sourced from a UL approved wiring harness manufacturer. SELV Cable to be rated minimum 80V, 130C
- F. Product safety label must be printed on UL approved label stock and printer ribbon. Alternatively labels can be purchased from a UL approved label manufacturer.
- G. The product must be marked with the correct regulatory markings to support the certifications that are specified in this document

 <b>台達電子工業股份有限公司</b> <b>DELTA ELECTRONICS, INC.</b>				DESCRIPTION :	
				電氣規格 (Electrical Specification)	
THESE DRAWINGS AND SPECIFICATIONS ARE THE PROPERTY OF DELTA ELECTRONICS, INC. AND SHALL NOT BE REPRODUCED OR USED AS THE BASIS FOR THE MANUFACTURE OR SELL OF APPARATUSES OR DEVICES WITHOUT PERMISSION.				MODEL NO. :	
				DPS-550AB-36 S	
Date	Drawn	Design (EE)	Design (ME)	DOCUMENT NAME. :	REV.
10/18/'21	金雨霞	陳雨	賈曉東	ES-550AB-36 S	S03

### 13.4.1 Harmonics and Voltage Flicker Compliance Information

#### Input Line Current Harmonic Content (PFC)

The power supply shall meet the requirements of EN61000-3-2 Class A and the Guidelines for the Suppression of Harmonics in Appliances and General Use Equipment Class A for harmonic line current content at full rated power.

Table 13.4.1 Harmonic Limits for Class A equipment

	Per: EN 61000-3-2	Per: JEIDA MITI
Harmonic Order <i>n</i>	Maximum permissible Harmonic current at <u>230Vac/50Hz</u> in Amps	Maximum permissible Harmonic current at <u>100Vac/50Hz</u> in Amps
<i>Odd harmonics</i>		
3	2.3	5.29
5	1.14	2.622
7	0.77	1.771
9	0.4	0.92
11	0.33	0.759
13	0.21	0.483
$15 \leq n \leq 39$	$0.15x (15/n)$	$0.345x (15/n)$
<i>Even harmonics</i>		
2	1.08	2.484
4	0.43	0.989
6	0.3	0.69
$8 \leq n \leq 40$	$0.23x (8/n)$	$0.529x (8/n)$

### 13.5 Other Safety Requirement Notations

#### 13.5.1 Certification Conditions

Safety certifications shall not be contingent to any unusual or difficult Conditions of Acceptability such as mandatory additional cooling or power de-rating

#### 13.5.2 Isolation between Primary - Secondary

Reinforced insulation must be used between primary and secondary circuits

#### 13.5.3 Creepage & Clearance Requirements

Creepage and Clearance distances must comply with those specified by safety standards  
Creepage distances require meeting 5000M attitude to comply with China GB4943.1-2011

 <b>台達電子工業股份有限公司</b> <b>DELTA ELECTRONICS, INC.</b>				DESCRIPTION :	
				電氣規格 (Electrical Specification)	
THESE DRAWINGS AND SPECIFICATIONS ARE THE PROPERTY OF DELTA ELECTRONICS, INC. AND SHALL NOT BE REPRODUCED OR USED AS THE BASIS FOR THE MANUFACTURE OR SELL OF APPARATUSES OR DEVICES WITHOUT PERMISSION.				MODEL NO. :	
				DPS-550AB-36 S	
Date	Drawn	Design (EE)	Design (ME)	DOCUMENT NAME. :	REV.
10/18/'21	金雨霞	陳雨	賈曉東	ES-550AB-36 S	S03

#### 13.5.4 Leakage Current Maximums

Maximum leakage current to ground shall be less than 1.3mA 240VAC/50HZ

#### 13.5.5 Max Surface Temperatures

The temperature of the power supply chassis shall not exceed 70 °C under all circumstances. Otherwise, a UL international HOT SURFACE label is required. If this HOT SURFACE label is required, it shall be placed in such a manner that when the power supply is extracted from the system, the label shall be visible before the operator has a chance to touch the hot surface of the power supply.

#### 13.5.6 Date Coded Serial Numbers

Power supply shall be marked with a date-coded number for traceability purposes and to comply with CSA 950 marking requirements

#### 13.5.7 Power Input Electrical Ratings

Power supply shall be tested to allow Nominal AC input operating voltages (100-127VAC and 200-240 VAC) and current rating. 127V is required for countries such as Mexico  
The earth safety conductor shall be color-coded green/yellow and suitable sized for the max current of the power supply.

#### 13.5.8 Maximum Allowable Temperatures on Inlet Receptacles

The inlet receptacle shall be suitably rated for the maximum operating temperature to the power supply, when installed in a rack environment.

#### 13.5.9 Maximum Allowable Temperatures on Power Cords

The exhaust air of the power supply shall not impose temperatures that will exceed the maximum allowable temperature of the power cord.

#### 13.5.10 China GB4943.1-2011 Tropical Environment

The power supply shall be tested and meet the Tropical Environmental requirements per China GB4943.1-2011

#### 13.5.11 Insulation resistance

Primary to safety ground: 500Vdc, 30M ohms min

### 13.6 Power Supply, Cage & Module Regulatory & Safety Markings

The power supply vendor shall mark the power supply with the following product regulation markings. The Barcode shall follow code 39 format.

### 13.7 Other Safety / Regulatory Marks on Power Supplies

#### 13.7.1 Power Supply Model Designation

The power supply model designation must be marked on the power supply. All regulatory certifications and documents must carry the same model designation for traceability purposes.

#### 13.7.2 Electrical Input & Output Ratings

 台達電子工業股份有限公司 <b>DELTA ELECTRONICS, INC.</b>				DESCRIPTION : 電氣規格 (Electrical Specification)	
THESE DRAWINGS AND SPECIFICATIONS ARE THE PROPERTY OF DELTA ELECTRONICS, INC. AND SHALL NOT BE REPRODUCED OR USED AS THE BASIS FOR THE MANUFACTURE OR SELL OF APPARATUSES OR DEVICES WITHOUT PERMISSION.				MODEL NO. : <b>DPS-550AB-36 S</b>	
Date	Drawn	Design (EE)	Design (ME)	DOCUMENT NAME. :	REV.
10/18/'21	金雨霞	陳雨	賈曉東	<b>ES-550AB-36 S</b>	<b>S03</b>

The AC or DC electrical input ratings (V, A, Hz), and secondary electrical output ratings (V, A, W >total output power<) must be marked on the power supply.  
 If possible, the end system input electrical ratings should also be marked on the power supply. These markings need to be visible to the outside of the end system. These electrical rating for the end system may be different than the ones for the power supply – this is acceptable. Marking the power supply with the end system electrical ratings, provides flexibility if the end system may be configured with various power supplies. This ultimately reduces the need to change the end system electrical rating label each time the system is configured with a different power supply.

**13.7.3 Shock Hazard & Service Only Warning**

The power supply module shall be marked with the international label shown below to indicate that no user serviceable parts are contained in the power supply. This label shall be printed on bright yellow vinyl label stock with black symbols.

**Example Only**

*Size may vary depending on room and location on power supply*

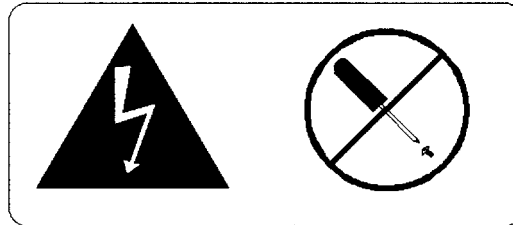

**13.7.4 Caution Hot Surface Warning**

The power supply shall be marked with a Caution Hot Surface Warning label. The label shall be located in such that when servicing takes place the service person will first see the label. For redundant type modules, the label should be seen first as the module is being extracted from the power supply cage.

**13.7.5 Protective Earth Ground Symbol**

The IEC 417, No 5091a protective earth symbol, shall be marked adjacent to the protective earth termination.



**13.7.6 Line & Neutral Terminal Markings**

The Line and Neutral Terminals coming into the power supply shall be marked with the “L” for Line and “N” for Neutral. Typically these markings are silk screened on the power supply printed wiring board adjacent to the Line and Neutral terminals

**13.7.7 Fuse Markings**

DELTA CONFIDENTIAL

 <b>台達電子工業股份有限公司</b> <b>DELTA ELECTRONICS, INC.</b>				DESCRIPTION : 電氣規格 (Electrical Specification)	
THESE DRAWINGS AND SPECIFICATIONS ARE THE PROPERTY OF DELTA ELECTRONICS, INC. AND SHALL NOT BE REPRODUCED OR USED AS THE BASIS FOR THE MANUFACTURE OR SELL OF APPARATUSES OR DEVICES WITHOUT PERMISSION.				MODEL NO. : <b>DPS-550AB-36 S</b>	
Date	Drawn	Design (EE)	Design (ME)	DOCUMENT NAME. :	REV.
10/18/'21	金雨霞	陳雨	賈曉東	<b>ES-550AB-36 S</b>	<b>S03</b>

The AC fuse (line and/or neutral) shall be marked with the fuse electrical rating and type, adjacent to the fuse(s). Also the fuse component designation shall be marked adjacent to the fuse.

Example: F1, 250V, 10A, SB.

## 14 Firmware Description

### 14.1 PMBus command for Smart On

#### 14.1.1 Hardware Connection

Before enabling Smart On function, make sure pin B22 (SMART ON) on output golden finger of each PSU is connected together.

#### 14.1.2 Configuring Smart On with SMART\_ON\_CONFIG (D0h)

The PMBus manufacturer specific command MFR\_SPECIFIC\_00 is used to configure the operating state of the power supply related to Smart On. We will call the command SMART\_ON\_CONFIG (D0h). Below is the definition of the values used with the Read-Write Byte SMBus protocol with PEC.

The power supplies setup to be the Smart standby power supplies; shall change to standard redundancy mode (D0h = 00h) whenever the SMART\_ON# is pulled low.

Table 14.1.2: SMART\_ON\_CONFIG command

SMART_ON_CONFIG (D0h)		
Value	State	Description
00h	Standard Redundancy (default power on state)	Turns the power supply ON into standard redundant load sharing mode.
01h	Smart on Active	Defines this power supply to be the one that is always ON in a Smart On configuration.
02h	Smart Standby	Defines the power supply that is first to turn on in a Smart On configuration as the load increases.

The default state of power supply is in Standard Redundancy mode. Power supply need to be re-specified a state whenever initial power on or any power supply in the system is in fault situation.

The SMART\_ON\_CONFIG command will reset to 00h (Standard Redundancy) when any fault or over current happened. The faults include AC loss, over hot spot temperature, over ambient temperature, +12V short internally (under voltage), +12V over voltage, fan locked.

#### 14.1.3 Smart Standby Power Supply Operating State

A power supply is put into Smart Standby whenever PSON# is asserted, SMART\_ON# is de-asserted, and SMART\_ON\_CONFIG value is set to 02h. In the Smart Standby mode the power supply must:

1. Power ON when SMART\_ON bus is driven LOW
2. Keep PWOK asserted
3. No PMBus fault or warning conditions reported via STATUS commands
4. LED is green blinking

 <b>台達電子工業股份有限公司</b> <b>DELTA ELECTRONICS, INC.</b>				DESCRIPTION : 電氣規格 (Electrical Specification)	
THESE DRAWINGS AND SPECIFICATIONS ARE THE PROPERTY OF DELTA ELECTRONICS, INC. AND SHALL NOT BE REPRODUCED OR USED AS THE BASIS FOR THE MANUFACTURE OR SELL OF APPARATUSES OR DEVICES WITHOUT PERMISSION.				MODEL NO. : <b>DPS-550AB-36 S</b>	
Date	Drawn	Design (EE)	Design (ME)	DOCUMENT NAME. :	REV.
10/18/'21	金雨霞	陳雨	賈曉東	<b>ES-550AB-36 S</b>	<b>S03</b>

#### 14.1.4 Powering on Smart Standby supplies to maintain best efficiency

Power supplies in Smart Standby state shall monitor the shared voltage level of the load share signal to sense when it needs to power on. Depending upon which position the system defines that power supply to be in the Smart Standby configuration; will slightly change the load share threshold that the power supply shall power on at.

#### 14.1.5 Powering on Smart Standby supplies during a fault or over current condition

12V output shutdown due to any fault will cause SMART\_ON# driven low.

When an active power supply asserts its SMART\_ON# signal, all parallel power supplies in Smart Standby mode shall power on immediately.

The trigger condition:

1. 12V OC warning/ fault happens
2. 12V OVP fault
3. OTP warning/ fault
4. Fan speed fault
5. AC loss (lower than 75V +/-5V)
6. Send 00h to PMBus D0h command

When an active power supply asserts its SMART\_ON# signal, all parallel power supplies in Smart Standby mode shall power on immediately.

#### 14.2 Data Formats

The data format for current, voltage, power, temperature, and fan speed shall use the PMBus Literal format.

Literal data format:  $X = Y \cdot 2^N$

X = the sensor value in volts, amps, watts, degrees C, or RPM

Y = mantissa

The mantissa is the variable components that changes as the sensor value changes.

Y is a 16 bit unsigned value for the READ\_VOUT command. For all other READ commands Y is a 11 bit signed 2's compliment value.

N = exponent. The exponents are fixed for each power supply and define the resolution for each sensor.

#### 14.3 VOUT\_MODE

For reading output voltages the power supply shall support the VOUT\_MODE command to report the output voltage formatting for the READ\_VOUT command. The VOUT\_MODE shall be set to Linear and the exponent (N) shall be set to -9.

Table 11: VOUT\_MODE settings for reading output voltage(s).

Mode	Bit[7:5]	Bit[4:0]
Linear	000b	10111b(-9)



台達電子工業股份有限公司  
DELTA ELECTRONICS, INC.

DESCRIPTION :

電氣規格 (Electrical Specification)

THESE DRAWINGS AND SPECIFICATIONS ARE THE PROPERTY OF DELTA ELECTRONICS, INC. AND SHALL NOT BE REPRODUCED OR USED AS THE BASIS FOR THE MANUFACTURE OR SELL OF APPARATUSES OR DEVICES WITHOUT PERMISSION.

MODEL NO. :

DPS-550AB-36 S

Date

Drawn

Design (EE)

Design (ME)

DOCUMENT NAME. :

REV.

10/18/'21

金雨霞

陳雨

賈曉東

ES-550AB-36 S

S03



## 14.4 READ\_EIN

The READ\_EIN commands are used to return information the host can use to calculate the input power consumption of a PMBus device. The information provided by this command is independent of any device specific averaging period, sampling frequency, or calculation algorithm.

Each command returns six data bytes. The first two bytes are the output of an accumulator that continuously sums samples of the instantaneous input power (the product of the samples of the input voltage and input current). The accumulator value is scaled so that the units are “watt-samples”. The PMBus device product literature shall clearly state which format the device uses.

The next data byte is a ROLLOVER\_COUNT for the accumulator. This byte is an unsigned integer. The ROLLOVER\_COUNT will periodically roll over from its maximum positive value to zero. It is up to the host to keep track of the state of the ROLLOVER\_COUNT and account for the rollovers.

The other three data bytes are a 24 bit unsigned integer that counts the number of samples of the instantaneous input power. This value will also roll over periodically from its maximum positive value to zero. It is up to the host to keep track of the sample count and account for the rollovers.

The format of the accumulator we used is Direct Format, the calculation of the energy count is as follows.

$$\text{Energy\_Count} = \text{Rollover\_Count} * \text{Maximum\_Direct\_Format\_Value}(m, b, R) + \text{Accumulator\_Value}$$

Where the maximum Direct Format value is a function of the current values of m, b, R:

$$\text{Maximum\_Direct\_Format\_Value}(m, b, R) = \frac{1}{m} \cdot (Y_{MAX} \cdot 10^{-R} - b)$$

And

$$Y_{MAX} = 2^{15} - 1 = 32,767$$

The host calculates the average power since the last reading using the formula:

$$\text{Average\_Power} = \frac{\text{Current\_Energy\_Count} - \text{Last\_Energy\_Count}}{\text{Current\_Sample\_Count} - \text{Last\_Sample\_Count}}$$

Figure 14.4 shows an example of the READ\_EIN command packet format when using Packet Error Checking (PEC)

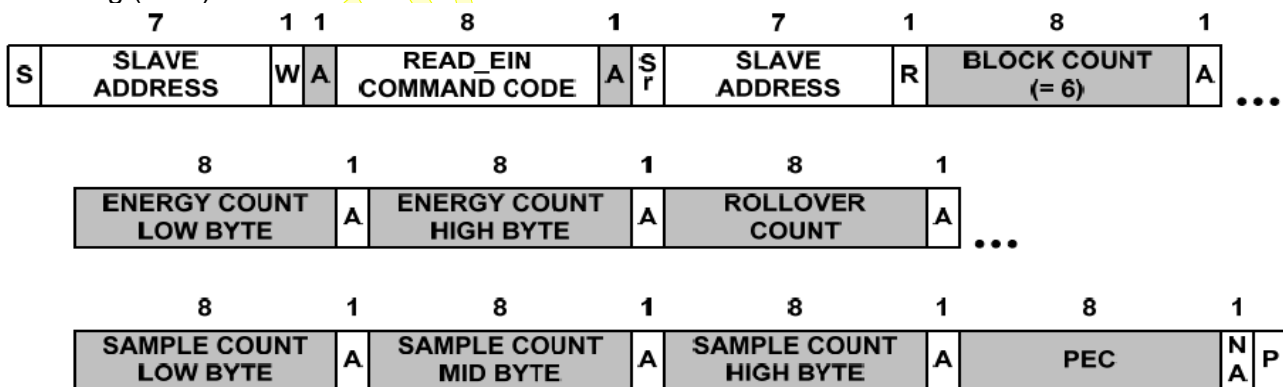



Figure 14.4 READ\_EIN Command Packet Format

 <b>台達電子工業股份有限公司</b> <b>DELTA ELECTRONICS, INC.</b>				DESCRIPTION : 電氣規格 (Electrical Specification)	
THESE DRAWINGS AND SPECIFICATIONS ARE THE PROPERTY OF DELTA ELECTRONICS, INC. AND SHALL NOT BE REPRODUCED OR USED AS THE BASIS FOR THE MANUFACTURE OR SELL OF APPARATUSES OR DEVICES WITHOUT PERMISSION.				MODEL NO. : <b>DPS-550AB-36 S</b>	
Date	Drawn	Design (EE)	Design (ME)	DOCUMENT NAME. :	REV.
10/18/'21	金雨霞	陳雨	賈曉東	ES-550AB-36 S	S03

### 14.5 PMBus Command list

Command Code	Command Name	Number Of Data Bytes	PSU Transaction Type
03h	CLEAR_FAULTS	0	Send Byte
05h	PAGE_PLUS_WRITE		Block Write
06h	PAGE_PLUS_READ		Block Write-Block Read Process Call
19h	CAPABILITY	1	Read Byte
1Ah	QUERY		BW-BR Process Call
1Bh	SMBALERT_MASK		BW-BR Process Call
30h	COEFFICIENTS		BW-BR Process Call
3Ah	FAN_CONFIG	1	Read/Write Byte
3Bh	FAN_COMMAND_1	2	R/W Word
51h	OT_WARN_LIMIT	2	R/W Word
79h	STATUS_WORD	2	Read Word
(Low)bit6	OFF		
bit5	VOUT_OV_FAULT		
bit4	IOUT_OC		
bit2	TEMPERATURE		
bit1	CML		
bit0	NON OF THE ABOVE		
(High)bit7	VOUT		
bit6	IOUT/POUT		
bit5	INPUT		
bit3	POWER_GOOD#		
bit2	FANS		
7Bh	STATUS_IOUT	1	Read Byte
bit7	IOUT_OC_FAULT		
bit5	IOUT_OC_WARNING		
bit0	POUT_OP_WARNING		
7Ch	STATUS_INPUT	1	Read Byte
bit5	VIN_UV_WARNING		
bit4	VIN_UV_FAULT		
bit3	Unit Off For Low Input Voltage		
bit1	IIN_OC_WARNING		
bit0	PIN_OP_WARNING		
7Dh	STATUS_TEMPERATURE	1	Read Byte
bit7	OT_FAULT		
bit6	OT_WARNING		
81h	STATUS_FANS_1_2	1	Read Byte

 <b>台達電子工業股份有限公司</b> <b>DELTA ELECTRONICS, INC.</b>				DESCRIPTION :	
				電氣規格 (Electrical Specification)	
THESE DRAWINGS AND SPECIFICATIONS ARE THE PROPERTY OF DELTA ELECTRONICS, INC. AND SHALL NOT BE REPRODUCED OR USED AS THE BASIS FOR THE MANUFACTURE OR SELL OF APPARATUSES OR DEVICES WITHOUT PERMISSION.				MODEL NO. :	
				DPS-550AB-36 S	
Date	Drawn	Design (EE)	Design (ME)	DOCUMENT NAME. :	REV.
10/18/'21	金雨霞	陳雨	賈曉東	ES-550AB-36 S	S03

bit7	Fan 1 fault		
bit5	Fan 1 Warning		
86h	READ_EIN	5	Block Read
87h	READ_EOUT	5	Block Read
88h	READ_VIN	2	Read Word
89h	READ_IIN	2	Read Word
8Bh	READ_VOUT	2	Read Word
8Ch	READ_IOUT	2	Read Word
8Dh	READ_TEMPERATURE_1	2	Read Word
8Eh	READ_TEMPERATURE_2	2	Read Word
8Fh	READ_TEMPERATURE_3	2	Read Word
90h	READ_FAN_SPEED_1	2	Read Word
96h	READ_POUT	2	Read Word
97h	READ_PIN	2	Read Word
98h	PMBUS_REVISION	1	Read Byte
99h	MFR_ID	5	Read Byte
9Ah	MFR_MODEL	14	Read Byte
9Bh	MFR_REVISION	2	Read Byte
9Ch	MFR_PN	14	Read Byte
9Eh	MFR_SN	16	Read Byte
9Fh	APP_PROFILE_SUPPORT	1	Read Byte
A6h	MFR_IOUT_MAX	2	Read Word
A7h	MFR_POUT_MAX	2	Read Word
C0h	MFR_MAX_TEMP_1	2	Read Word
C1h	MFR_MAX_TEMP_2	2	Read Word
D0h	SMART_ON_CONFIG	1	R/W Byte

DELTA CONFIDENTIAL

 <b>台達電子工業股份有限公司</b> <b>DELTA ELECTRONICS, INC.</b>				DESCRIPTION :	
THESE DRAWINGS AND SPECIFICATIONS ARE THE PROPERTY OF DELTA ELECTRONICS, INC. AND SHALL NOT BE REPRODUCED OR USED AS THE BASIS FOR THE MANUFACTURE OR SELL OF APPARATUSES OR DEVICES WITHOUT PERMISSION.				電氣規格 (Electrical Specification)	
				MODEL NO. :	
				DPS-550AB-36 S	
Date	Drawn	Design (EE)	Design (ME)	DOCUMENT NAME. :	REV.
10/18/'21	金雨霞	陳雨	賈曉東	ES-550AB-36 S	S03

Mfg Data &amp; Time

2021/09/24

15:12:00

## DPS-550AB-36 S FRU MEMORY MAP

ITEM	ADDRESS	VALUE		DESCRIPTION	BLOCK TITLE
		DEC	HEX		
1	0x00	1	1	Common Header Format Version	Common Header
2	0x01	1	1	Internal Use Area Starting Offset	
3	0x02	0	0	Chassis Info Area Starting Offset	
4	0x03	0	0	Board Area Starting Offset	
5	0x04	3	3	Product Info Area Starting Offset	
6	0x05	11	B	MultiRecord Area Starting Offset	
7	0x06	0	0	PAD, write as 00h	
8	0x07	245	F5	Common Header Checksum (zero checksum)	
1	0x08	1	1		
2	0x09	35	23		
3	0x0A	0	0		
4	0x0B	0	0		
5	0x0C	0	0		
6	0x0D	100	64		
7	0x0E	2	2		
8	0x0F	0	0		
9	0x10	0	0		
10	0x11	0	0		
11	0x12	0	0		
12	0x13	0	0		
13	0x14	0	0		
14	0x15	0	0		
15	0x16	18	12		
16	0x17	2	2		
1	0x18	1	1	Product Area Format Version	Product information Area
2	0x19	8	8	Product Area Length	
3	0x1A	25	19	Language Code	
4	0x1B	197	C5	Manufacturers Name Type/Length	
5	0x1C	68	44	D	
6	0x1D	69	45	E	



台達電子工業股份有限公司

DELTA ELECTRONICS, INC.

DESCRIPTION :

電氣規格 (Electrical Specification)

THESE DRAWINGS AND SPECIFICATIONS ARE THE PROPERTY OF DELTA ELECTRONICS, INC. AND SHALL NOT BE REPRODUCED OR USED AS THE BASIS FOR THE MANUFACTURE OR SELL OF APPARATUSES OR DEVICES WITHOUT PERMISSION.

MODEL NO. :

DPS-550AB-36 S

Date

Drawn

Design (EE)

Design (ME)

DOCUMENT NAME. :

REV.

10/18/'21

金雨霞

陳雨

賈曉東

ES-550AB-36 S

S03

7	0x1E	76	4C	L	
8	0x1F	84	54	T	
9	0x20	65	41	A	
10	0x21	206	CE	Product Name Type/Length	
11	0x22	68	44	D	
12	0x23	80	50	P	
13	0x24	83	53	S	
14	0x25	45	2D	-	
15	0x26	53	35	5	
16	0x27	53	35	5	
17	0x28	48	30	0	
18	0x29	65	41	A	
19	0x2A	66	42	B	
20	0x2B	45	2D	-	
21	0x2C	51	33	3	
22	0x2D	54	36	6	
23	0x2E	32	20		
24	0x2F	83	53	S	
25	0x30	202	CC	Product Part/Model Number type/length	
26	0x31	68	44	D	
27	0x32	80	50	P	
28	0x33	83	53	S	
29	0x34	53	35	5	
30	0x35	53	35	5	
31	0x36	48	30	0	
32	0x37	65	41	A	
33	0x38	66	42	B	
34	0x39	51	33	3	
35	0x3A	54	36	6	
36	0x3B	83	53	S	
37	0x3C	32	20		
38	0x3D	195	C3	Product Version No.Type/Length	
39	0x3E	88	58	X	To be updated
40	0x3F	88	58	X	To be updated
41	0x40	70	46	F	
42	0x41	206	CE	Product Serial No.Type/Length	
43	0x42	88	58	X	To be updated
44	0x43	88	58	X	To be updated
45	0x44	88	58	X	To be updated
46	0x45	88	58	X	To be updated

 <b>台達電子工業股份有限公司</b> <b>DELTA ELECTRONICS, INC.</b>				<b>DESCRIPTION :</b> <b>電氣規格 (Electrical Specification)</b>	
<small>THESE DRAWINGS AND SPECIFICATIONS ARE THE PROPERTY OF DELTA ELECTRONICS, INC. AND SHALL NOT BE REPRODUCED OR USED AS THE BASIS FOR THE MANUFACTURE OR SELL OF APPARATUSES OR DEVICES WITHOUT PERMISSION.</small>				<b>MODEL NO. :</b> <b>DPS-550AB-36 S</b>	
<b>Date</b>	<b>Drawn</b>	<b>Design (EE)</b>	<b>Design (ME)</b>	<b>DOCUMENT NAME. :</b>	<b>REV.</b>
10/18/'21	金雨霞	陳雨	賈曉東	<b>ES-550AB-36 S</b>	<b>S03</b>

47	0x46	88	58	X	To be updated
48	0x47	88	58	X	To be updated
49	0x48	88	58	X	To be updated
50	0x49	88	58	X	To be updated
51	0x4A	88	58	X	To be updated
52	0x4B	88	58	X	To be updated
53	0x4C	88	58	X	To be updated
54	0x4D	88	58	X	To be updated
55	0x4E	88	58	X	To be updated
56	0x4F	88	58	X	To be updated
57	0x50	192	C0	Asset Tag type/length byte	
58	0x51	192	C0	FRU File ID type/length byte	
59	0x52	194	C2	FW Version No.Type/Length	
60	0x53	88	58	X	To be updated
61	0x54	88	58	X	To be updated
62	0x55	193	C1	End of Fields	
63	0x56	0	0	PAD(Always Zero)	
64	0x57	164	A4	Product Info Area Checksum (zero checksum)	To be updated
	0x58	0	0	Record Type ID 0x00 = Power Supply Information	Multirecord Header
	0x59	2	2	7:7 – End of list 6:4 – 000b 3:0 – Record Format version = 2	
	0x5A	24	18	Record Length Of Multirecord	
	0x5B	36	24	Record Checksum	
	0x5C	194	C2	Header Checksum	
0	0x5D	38	26	15:12 – Reserved, write as 0000b	550W
1	0x5E	2	2	11:0 - Overall capacity (watts) (LSB First)	
2	0x5F	113	71	Peak VA	625W
3	0x60	2	2	Inrush current	55A
4	0x61	55	37	Inrush interval in ms.	5mS
5	0x62	5	5	Low end Input voltage range 1 (10mV, LSB First )	90V
6	0x63	40	28	High end Input voltage range 1 (10mV, LSB First )	140V
7	0x64	35	23	Low end Input voltage range 2 (10mV, LSB First , Zero if single range)	180V
8	0x65	176	B0		
9	0x66	54	36		
10	0x67	80	50		
11	0x68	70	46		

 <b>台達電子工業股份有限公司</b> <b>DELTA ELECTRONICS, INC.</b>				<b>DESCRIPTION :</b> <b>電氣規格 (Electrical Specification)</b>	
<b>THESE DRAWINGS AND SPECIFICATIONS ARE THE PROPERTY OF DELTA ELECTRONICS, INC. AND SHALL NOT BE REPRODUCED OR USED AS THE BASIS FOR THE MANUFACTURE OR SELL OF APPARATUSES OR DEVICES WITHOUT PERMISSION.</b>				<b>MODEL NO. :</b> <b>DPS-550AB-36 S</b>	
<b>Date</b>	<b>Drawn</b>	<b>Design (EE)</b>	<b>Design (ME)</b>	<b>DOCUMENT NAME. :</b>	<b>REV.</b>
10/18/'21	金雨霞	陳雨	賈曉東	<b>ES-550AB-36 S</b>	<b>S03</b>



12	0x69	32	20	High end Input voltage range 2 (10mV, LSB First , Zero if single range)	264V
13	0x6A	103	67		
14	0x6B	50	32	Low end Input frequency range	50HZ
15	0x6C	60	3C	High end Input frequency range	60HZ
16	0x6D	10	A	Input dropout tolerance in ms	10mS
17	0x6E	31	1F	Binary flags: 7:5 – Reserved, write as 0000b	
				4:4 – Tachometer pulses per rotation/Predictive fail pin polarity	
				3:3 – Hot Swap Support	
				2:2 – Autoswitch	
				1:1 - Power factor correction	
				0:0 - Predictive fail support	
18	0x6F	113	71	15:12 – Hold up time in seconds	10mS
19	0x70	162	A2	11:0 – Peak capacity (watts) (LSB First)	625W
20	0x71	0	0	Combined Wattage Byte 1: 7:4 – Voltage 1 3:0 – Voltage 2	
21	0x72	0	0	Byte 2:3 Total Combined Wattage (LSB First)	
22	0x73	0	0		
23	0x74	13	0D	Predictive fail tachometer lower threshold (RPS)	
	0x75	1	1	DC Output	Multirecord Header
	0x76	2	2	7:7 – End of list 6:4 – 000b 3:0 – Record Format version = 2	
	0x77	13	D	Record Length Of Multirecord	
	0x78	244	F4	Record Checksum	
	0x79	252	FC	Header Checksum	
1	0x7A	1	1	+12V 7 : Standby = 0 , 6-4 - 000b , 3-0 : Output Number = 0001B	+V12
2	0x7B	176	B0	Nominal voltage (10 mV)	12.0V
3	0x7C	4	4		
4	0x7D	116	74	Maximum negative voltage(10 mV)	11.4V
5	0x7E	4	4		
6	0x7F	236	EC	Maximum positive voltage(10 mV)	12.6V
7	0x80	4	4		
8	0x81	120	78	Ripple and Noise pk-pk 10Hz to 30 MHz (mV)	120mV
9	0x82	0	0		
10	0x83	0	0	Minimum current draw (mA)	0A
11	0x84	0	0		

 <b>台達電子工業股份有限公司</b> <b>DELTA ELECTRONICS, INC.</b>				<b>DESCRIPTION :</b> <b>電氣規格 (Electrical Specification)</b>	
THESE DRAWINGS AND SPECIFICATIONS ARE THE PROPERTY OF DELTA ELECTRONICS, INC. AND SHALL NOT BE REPRODUCED OR USED AS THE BASIS FOR THE MANUFACTURE OR SELL OF APPARATUSES OR DEVICES WITHOUT PERMISSION.				<b>MODEL NO. :</b> <b>DPS-550AB-36 S</b>	
Date	Drawn	Design (EE)	Design (ME)	DOCUMENT NAME. :	REV.
10/18/'21	金雨霞	陳雨	賈曉東	ES-550AB-36 S	S03

12	0x85	200	C8	Maximum current draw (mA)	45A
13	0x86	175	AF		
	0x85	1	1	DC Output	Multirecord Header
	0x86	130	82	7:7 – End of list 6:4 – 000b 3:0 – Record Format version = 2	
	0x85	13	D	Record Length Of Multirecord	
	0x8A	174	AE	Record Checksum	
	0x8B	194	C2	Header Checksum	
1	0x8C	130	82	+12VSB 7 : Standby = 1 , 6-4 - 000b , 3-0 : Output Number = 0010B	+12VSB
2	0x8D	176	B0	Nominal voltage (10 mV)	12.0V
3	0x8E	4	4		
4	0x8F	116	74	Maximum negative voltage(10 mV)	11.4V
5	0x90	4	4		
6	0x91	236	EC	Maximum positive voltage(10 mV)	12.6V
7	0x92	4	4		
8	0x93	120	78	Ripple and Noise pk-pk 10Hz to 30 MHz (mV)	120mV
9	0x94	0	0		
10	0x95	0	0	Minimum current draw (mA)	0A
11	0x96	0	0		
12	0x97	52	34	Maximum current draw (mA)	2.1A
13	0x98	8	8		
1	0x99	0	0	Unused Area	
2	0x9A	0	0	Unused Area	
3	0x9B	0	0	Unused Area	
4	0x9C	0	0	Unused Area	
5	0x9D	0	0	Unused Area	
6	0x9E	0	0	Unused Area	
7	0x9F	0	0	Unused Area	
8	0xA0	0	0	Unused Area	
9	0xA1	0	0	Unused Area	
10	0xA2	0	0	Unused Area	
11	0xA3	0	0	Unused Area	
12	0xA4	0	0	Unused Area	
13	0xA5	0	0	Unused Area	
14	0xA6	0	0	Unused Area	
15	0xA7	0	0	Unused Area	
16	0xA8	0	0	Unused Area	
17	0xA9	0	0	Unused Area	

 <b>台達電子工業股份有限公司</b> <b>DELTA ELECTRONICS, INC.</b>				<b>DESCRIPTION :</b> <b>電氣規格 (Electrical Specification)</b>	
<b>THESE DRAWINGS AND SPECIFICATIONS ARE THE PROPERTY OF DELTA ELECTRONICS, INC. AND SHALL NOT BE REPRODUCED OR USED AS THE BASIS FOR THE MANUFACTURE OR SELL OF APPARATUSES OR DEVICES WITHOUT PERMISSION.</b>				<b>MODEL NO. :</b> <b>DPS-550AB-36 S</b>	
<b>Date</b>	<b>Drawn</b>	<b>Design (EE)</b>	<b>Design (ME)</b>	<b>DOCUMENT NAME. :</b>	<b>REV.</b>
10/18/'21	金雨霞	陳雨	賈曉東	<b>ES-550AB-36 S</b>	<b>S03</b>

18	0xAA	0	0	Unused Area	
19	0xAB	0	0	Unused Area	
20	0xAC	0	0	Unused Area	
21	0xAD	0	0	Unused Area	
22	0xAE	0	0	Unused Area	
23	0xAF	0	0	Unused Area	
24	0xB0	0	0	Unused Area	
25	0xB1	0	0	Unused Area	
26	0xB2	0	0	Unused Area	
27	0xB3	0	0	Unused Area	
28	0xB4	0	0	Unused Area	
29	0xB5	0	0	Unused Area	
30	0xB6	0	0	Unused Area	
31	0xB7	0	0	Unused Area	
32	0xB8	0	0	Unused Area	
33	0xB9	0	0	Unused Area	
34	0xBA	0	0	Unused Area	
35	0xBB	0	0	Unused Area	
36	0xBC	0	0	Unused Area	
37	0xBD	0	0	Unused Area	
38	0xBE	0	0	Unused Area	
39	0xBF	0	0	Unused Area	
40	0xC0	0	0	Unused Area	
41	0xC1	0	0	Unused Area	
42	0xC2	0	0	Unused Area	
43	0xC3	0	0	Unused Area	
44	0xC4	0	0	Unused Area	
45	0xC5	0	0	Unused Area	
46	0xC6	0	0	Unused Area	
47	0xC7	0	0	Unused Area	
48	0xC8	0	0	Unused Area	
49	0xC9	0	0	Unused Area	
50	0xCA	0	0	Unused Area	
51	0xCB	0	0	Unused Area	
52	0xCC	0	0	Unused Area	
53	0xCD	0	0	Unused Area	
54	0xCE	0	0	Unused Area	
55	0xCF	0	0	Unused Area	
56	0xD0	0	0	Unused Area	

DRAFT

DRAFT

 <b>台達電子工業股份有限公司</b> <b>DELTA ELECTRONICS, INC.</b>				DESCRIPTION :	
				電氣規格 (Electrical Specification)	
THESE DRAWINGS AND SPECIFICATIONS ARE THE PROPERTY OF DELTA ELECTRONICS, INC. AND SHALL NOT BE REPRODUCED OR USED AS THE BASIS FOR THE MANUFACTURE OR SELL OF APPARATUSES OR DEVICES WITHOUT PERMISSION.				MODEL NO. :	
				DPS-550AB-36 S	
Date	Drawn	Design (EE)	Design (ME)	DOCUMENT NAME. :	REV.
10/18/'21	金雨霞	陳雨	賈曉東	ES-550AB-36 S	S03

57	0xD1	0	0	Unused Area	
58	0xD2	0	0	Unused Area	
59	0xD3	0	0	Unused Area	
60	0xD4	0	0	Unused Area	
61	0xD5	0	0	Unused Area	
62	0xD6	0	0	Unused Area	
63	0xD7	0	0	Unused Area	
64	0xD8	0	0	Unused Area	
65	0xD9	0	0	Unused Area	
66	0xDA	0	0	Unused Area	
67	0xDB	0	0	Unused Area	
68	0xDC	0	0	Unused Area	
69	0xDD	0	0	Unused Area	
70	0xDE	0	0	Unused Area	
71	0xDF	0	0	Unused Area	
72	0xE0	0	0	Unused Area	
73	0xE1	0	0	Unused Area	
74	0xE2	0	0	Unused Area	
75	0xE3	0	0	Unused Area	
76	0xE4	0	0	Unused Area	
77	0xE5	0	0	Unused Area	
78	0xE6	0	0	Unused Area	
79	0xE7	0	0	Unused Area	
80	0xE8	0	0	Unused Area	
81	0xE9	0	0	Unused Area	
82	0xEA	0	0	Unused Area	
83	0xEB	0	0	Unused Area	
84	0xEC	0	0	Unused Area	
85	0xED	0	0	Unused Area	
86	0xEE	0	0	Unused Area	
87	0xEF	0	0	Unused Area	
88	0xF0	0	0	Unused Area	
89	0xF1	0	0	Unused Area	
90	0xF2	0	0	Unused Area	
91	0xF3	0	0	Unused Area	
92	0xF4	0	0	Unused Area	
93	0xF5	0	0	Unused Area	
94	0xF6	0	0	Unused Area	
95	0xF7	0	0	Unused Area	

STIAL

DELTA

 <b>台達電子工業股份有限公司</b> <b>DELTA ELECTRONICS, INC.</b>				<b>DESCRIPTION :</b> 電氣規格 (Electrical Specification)	
THESE DRAWINGS AND SPECIFICATIONS ARE THE PROPERTY OF DELTA ELECTRONICS, INC. AND SHALL NOT BE REPRODUCED OR USED AS THE BASIS FOR THE MANUFACTURE OR SELL OF APPARATUSES OR DEVICES WITHOUT PERMISSION.				<b>MODEL NO. :</b> <b>DPS-550AB-36 S</b>	
<b>Date</b>	<b>Drawn</b>	<b>Design (EE)</b>	<b>Design (ME)</b>	<b>DOCUMENT NAME. :</b>	<b>REV.</b>
10/18/'21	金雨霞	陳雨	賈曉東	<b>ES-550AB-36 S</b>	<b>S03</b>

96	0xF8	0	0	Unused Area	
97	0xF9	0	0	Unused Area	
98	0xFA	0	0	Unused Area	
99	0xFB	0	0	Unused Area	
100	0xFC	0	0	Unused Area	
101	0xFD	0	0	Unused Area	
102	0xFE	0	0	Unused Area	
103	0xFF	0	0	Unused Area	

DELTA CONFIDENTIAL

 <b>台達電子工業股份有限公司</b> <b>DELTA ELECTRONICS, INC.</b>				DESCRIPTION :	
				電氣規格 (Electrical Specification)	
<small>THESE DRAWINGS AND SPECIFICATIONS ARE THE PROPERTY OF DELTA ELECTRONICS, INC. AND SHALL NOT BE REPRODUCED OR USED AS THE BASIS FOR THE MANUFACTURE OR SELL OF APPARATUSES OR DEVICES WITHOUT PERMISSION.</small>				MODEL NO. :	
				DPS-550AB-36 S	
Date	Drawn	Design (EE)	Design (ME)	DOCUMENT NAME. :	REV.
10/18/'21	金雨霞	陳雨	賈曉東	ES-550AB-36 S	S03

## FRU DATA FOLLOW WITH SPEC LABEL

Table showing DPS-550AB-36 S HEX information.

2021/09/24

Rev.V00

Addr	0	1	2	3	4	5	6	7	8	9	A	B	C	D	E	F
0	01	01	00	00	03	0B	00	F0	01	23	00	00	00	64	02	00
1	00	00	00	00	00	00	12	02	01	08	19	C5	44	45	4C	54
2	41	CE	44	50	53	2D	35	35	30	41	42	2D	33	36	20	53
3	CC	44	50	53	35	35	30	41	42	33	36	53		C3	58	58
4	46	CE	58	58	58	58	58	58	58	58	58	58	58	58	58	58
5	C0	C0	C2	58	58	C1	00	XX	00	02	18	24	C2	26	02	71
6	02	37	05	28	23	B0	36	50	46	20	67	32	3C	0A	1F	71
7	A2	00	00	00	0D	01	02	0D	F4	FC	01	B0	04	74	04	EC
8	04	78	00	00	00	C8	AF	01	82	0D	AE	C2	82	B0	04	74
9	04	EC	04	78	00	00	00	34	08	00	00	00	00	00	00	00
A	00	00	00	00	00	00	00	00	00	00	00	00	00	00	00	00
B	00	00	00	00	00	00	00	00	00	00	00	00	00	00	00	00
C	00	00	00	00	00	00	00	00	00	00	00	00	00	00	00	00
D	00	00	00	00	00	00	00	00	00	00	00	00	00	00	00	00
E	00	00	00	00	00	00	00	00	00	00	00	00	00	00	00	00
F	00	00	00	00	00	00	00	00	00	00	00	00	00	00	00	00

DELTA CONFIDENTIAL

 <b>台達電子工業股份有限公司</b> <b>DELTA ELECTRONICS, INC.</b>				DESCRIPTION :	
THESE DRAWINGS AND SPECIFICATIONS ARE THE PROPERTY OF DELTA ELECTRONICS, INC. AND SHALL NOT BE REPRODUCED OR USED AS THE BASIS FOR THE MANUFACTURE OR SELL OF APPARATUSES OR DEVICES WITHOUT PERMISSION.				電氣規格 (Electrical Specification)	
				MODEL NO. :	
				DPS-550AB-36 S	
Date	Drawn	Design (EE)	Design (ME)	DOCUMENT NAME. :	
10/18/'21	金雨霞	陳雨	賈曉東	ES-550AB-36 S	
				REV.	S03



# CHECK LIST

All data written to EEPROM should be ASCII code in hexadecimal format

Notes : All of the check Sum are Calculated by Zero Check Sum

NO.	Item	Address	Byte	Decription	Value
1	Checksum1	07H	1	100H-(LowByte Sum(00H~06H))	F0
2	Checksum2	57H	1	100H-(LowByte Sum(08H~46H))	Update
3	Checksum3	5BH	1	100H-(LowByte Sum(4DH~64H))	24
4	Checksum4	5CH	1	100H-(LowByte Sum(48H~4BH))	C2
5	Checksum5	78H	1	100H-(LowByte Sum(6AH~76H))	F4
6	Checksum6	79H	1	100H-(LowByte Sum(65H~68H))	FC
7	Checksum7	8AH	1	100H-(LowByte Sum(7CH~88H))	AE
8	Checksum8	8BH	1	100H-(LowByte Sum(77H~7AH))	C2
9	Manufacturer Name	1CH~20H	5	Use the ASCII Code	"DELTA"
10	Product Name	22H~2FH	14	Use the ASCII Code	"DPS-550AB-36 S"
11	PART/Model NO.	31H~3CH	12	Use the ASCII Code	DPS550AB36S
12	Product Version	3EH~40H	3	Use the ASCII Code	Update
13	Product Serial NO.	42H~4FH	14	Use the ASCII Code	Update
14	FW Version	53H~54H	2	Use the ASCII Code	Update
15	Unused Area	99H~FFH			0

DELTA CONFIDENTIAL

 <b>台達電子工業股份有限公司</b> <b>DELTA ELECTRONICS, INC.</b>				DESCRIPTION :	
				電氣規格 (Electrical Specification)	
THESE DRAWINGS AND SPECIFICATIONS ARE THE PROPERTY OF DELTA ELECTRONICS, INC. AND SHALL NOT BE REPRODUCED OR USED AS THE BASIS FOR THE MANUFACTURE OR SELL OF APPARATUSES OR DEVICES WITHOUT PERMISSION.				MODEL NO. :	
				DPS-550AB-36 S	
Date	Drawn	Design (EE)	Design (ME)	DOCUMENT NAME. :	REV.
10/18/'21	金雨霞	陳雨	賈曉東	ES-550AB-36 S	S03