

DK Composite Carbon Factory 2024-2025 Carbon Rims Catalogue



CATALOG

01 - 06	25MM Width Road Rims	17	32MM Gravel Road Rims Asymmetric
07	26 MM Width Road Rims	18	36MM Outer Width Gravel Rims(700C)
08	28MM Width Road Rims	19	30MM Width Gravel MTB Rims
09	21MM Inner Width Rims T700/T800 Series	20	MTB Rims Super Light Series
10 - 12	28MM Width Wave Shape Road Rims	21 - 24	MTB Rims Symmetric Series
13	25MM Width Road Rims Asymmetric	25 -28	MTB Rims Asymmetric Series
14 - 15	28MM Width Road Rims Asymmetric	29	MTB Wave Shape Rims
16	31MM Outer Width Gravel Rims(700C)	30	BMX Rims Series
	31MM Outer Width Gravel Wave Rims(700C)	31	Fatbike Rims Series

► 25mm Road Rims Clincher U-Shape

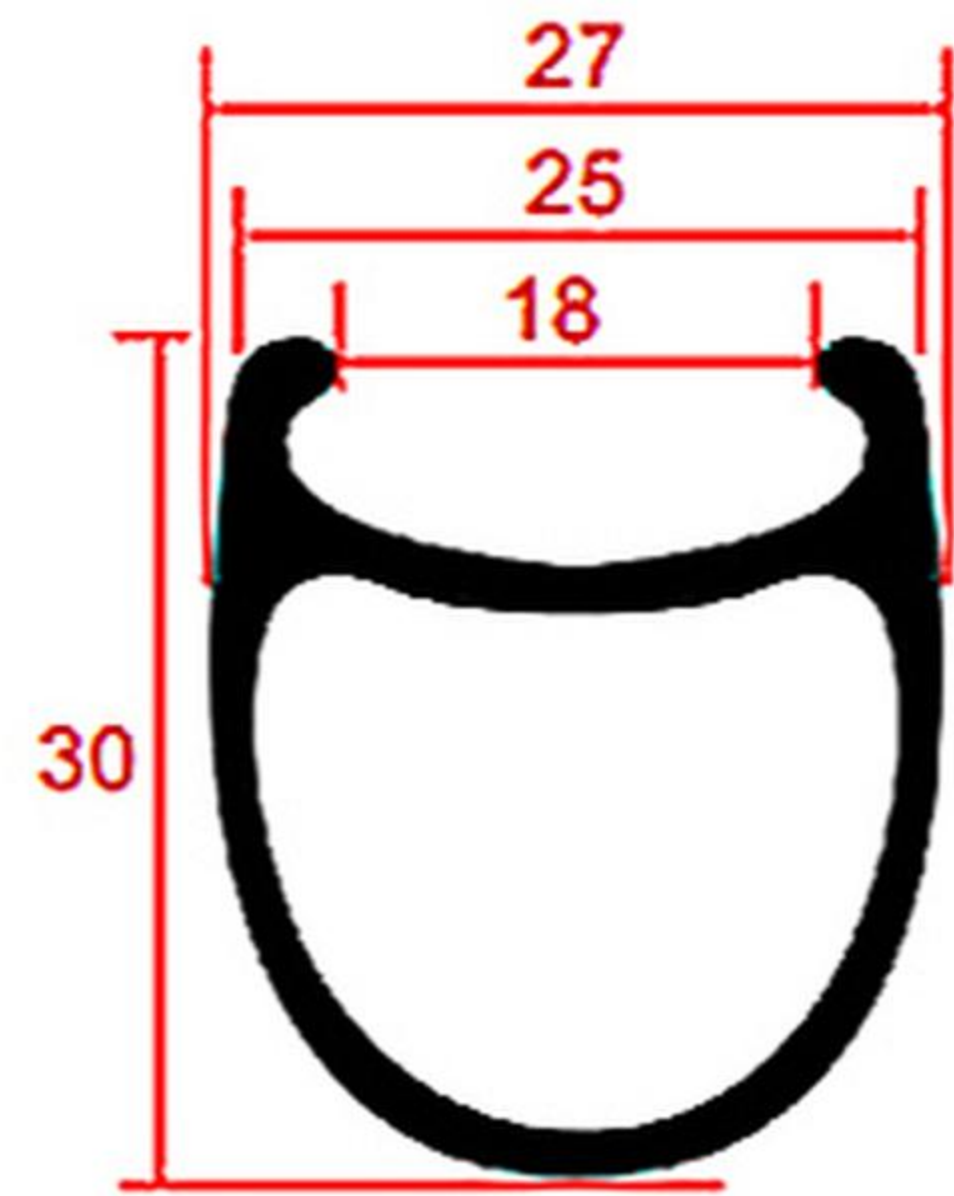

Model: R30C-25
Weight: T700:425+/-15g
T800:365+/-15g
ERD: 583

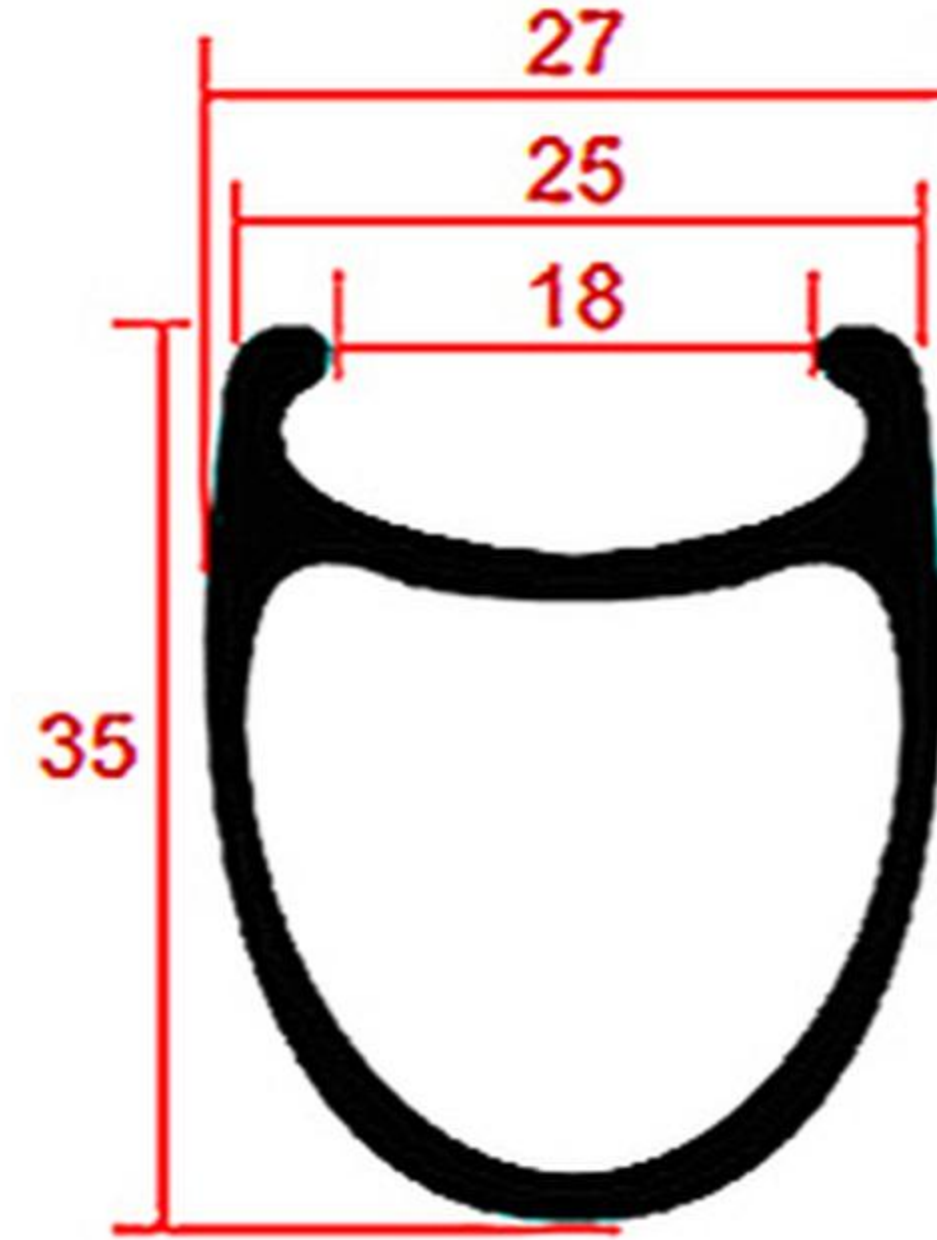

Model: R35C-25
Weight: T700:440/-15g
T800:375+/-15g
ERD: 573

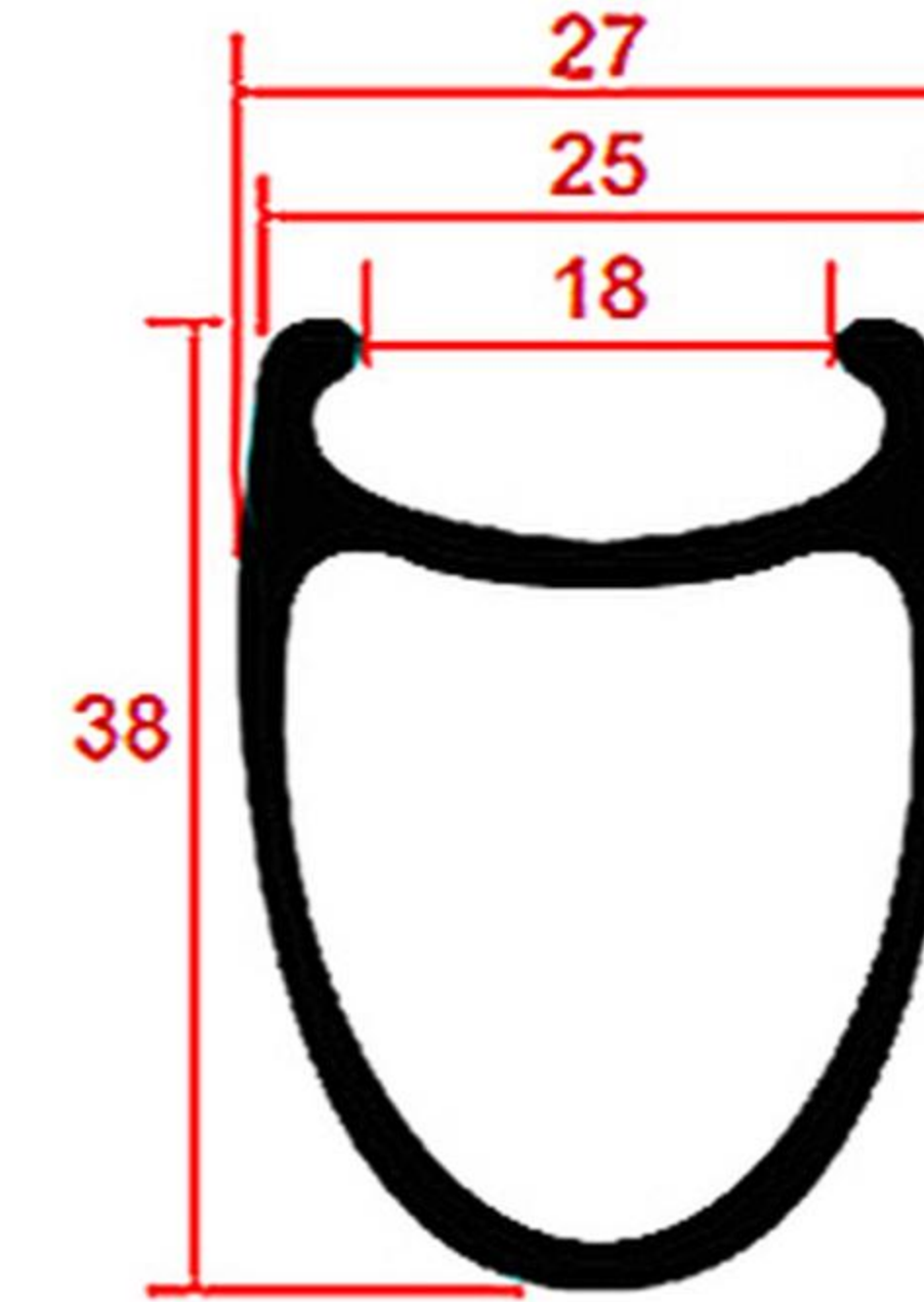

Model: R38C-25
Weight: T700:455+/-15g
T800:390+/-15g
ERD: 567

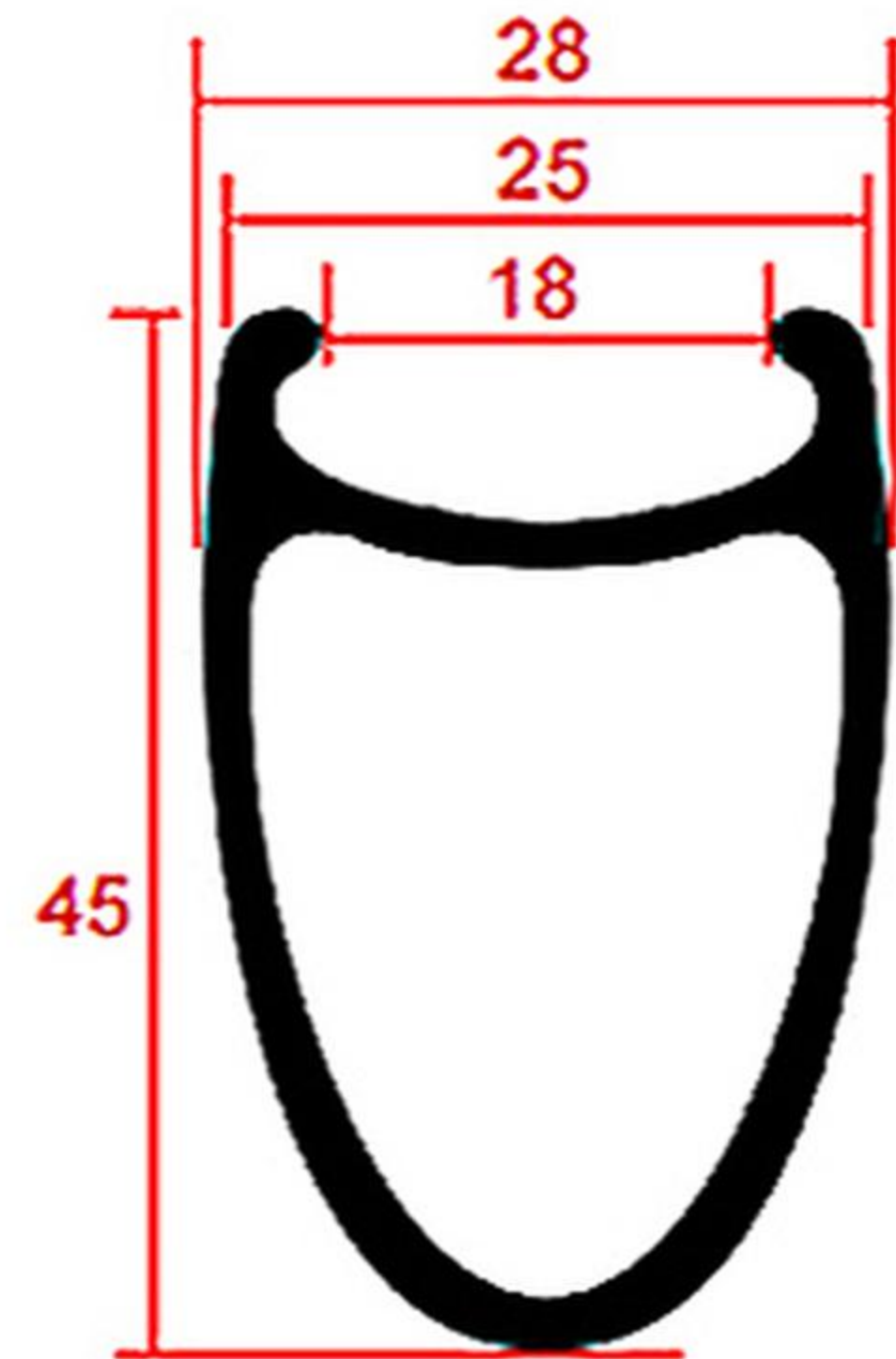

Model: R45C-25
Weight: T700:470+/-15g
T800:415+/-15g
ERD: 553

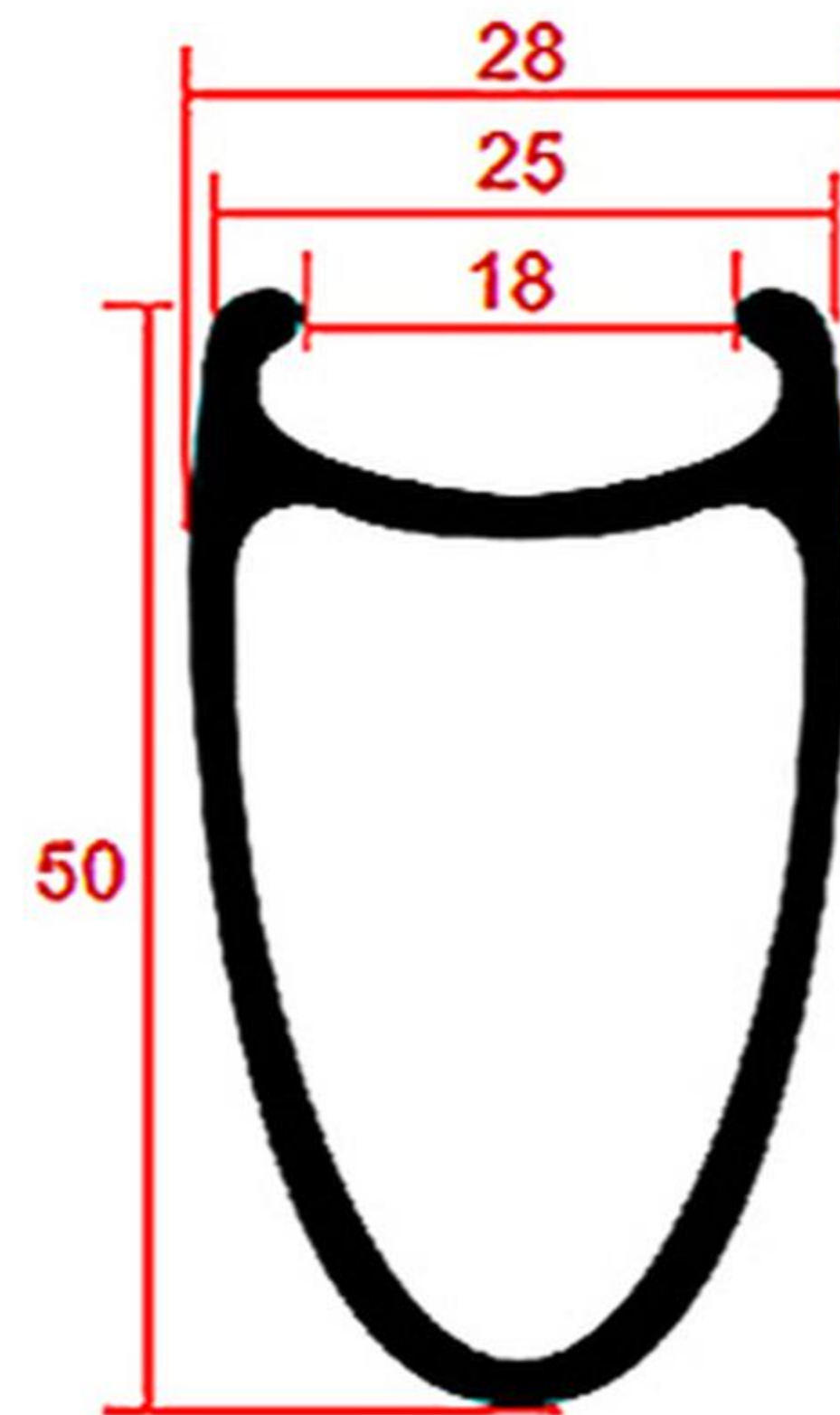

Model: R50C-25
Weight: T700:490+/-15g
T800:430+/-15g
ERD: 543

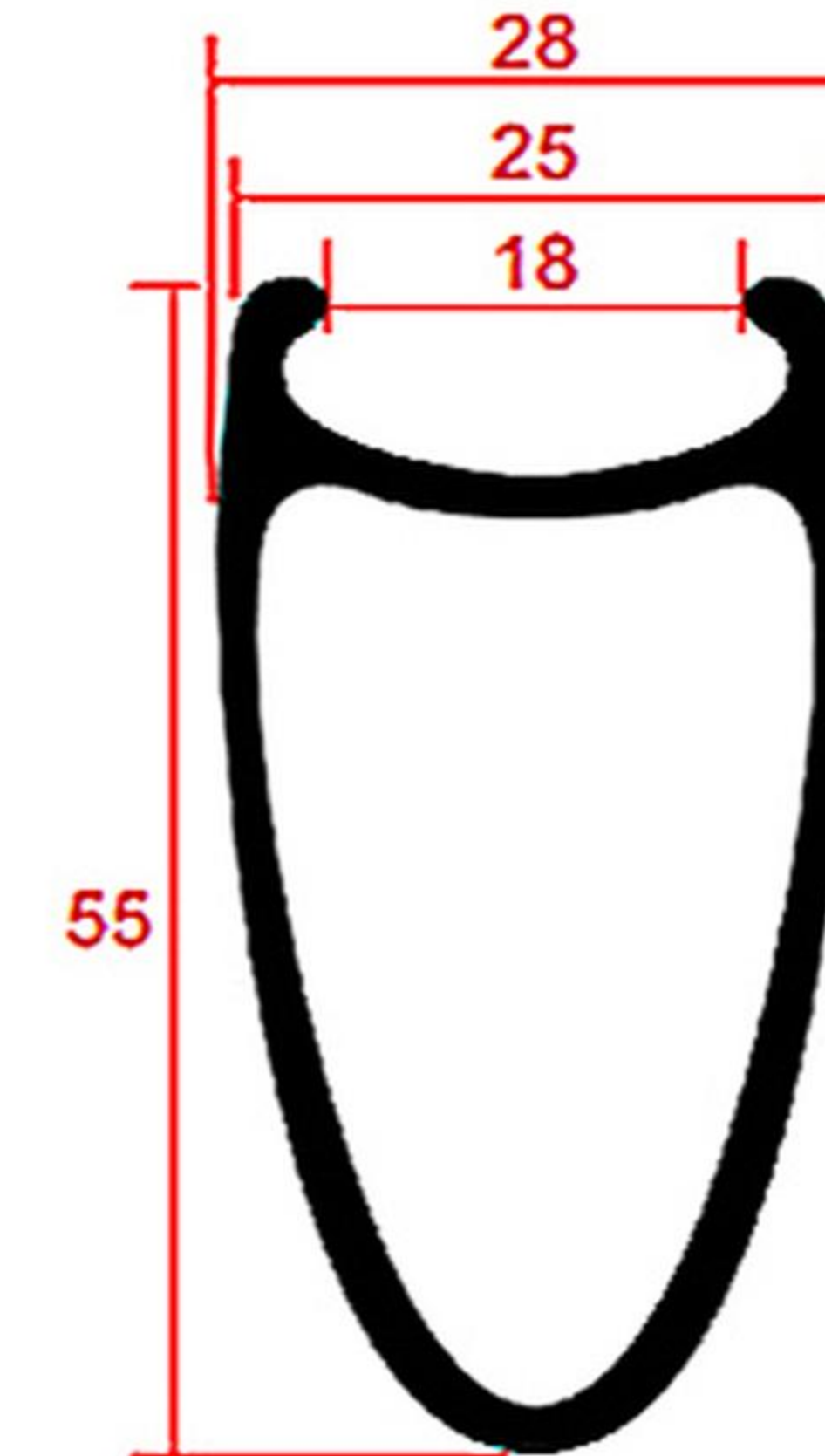

Model: R55C-25
Weight: T700:520+/-15g
T800:460+/-15g
ERD: 533

▶ 25mm Road Rims Clincher U-Shape

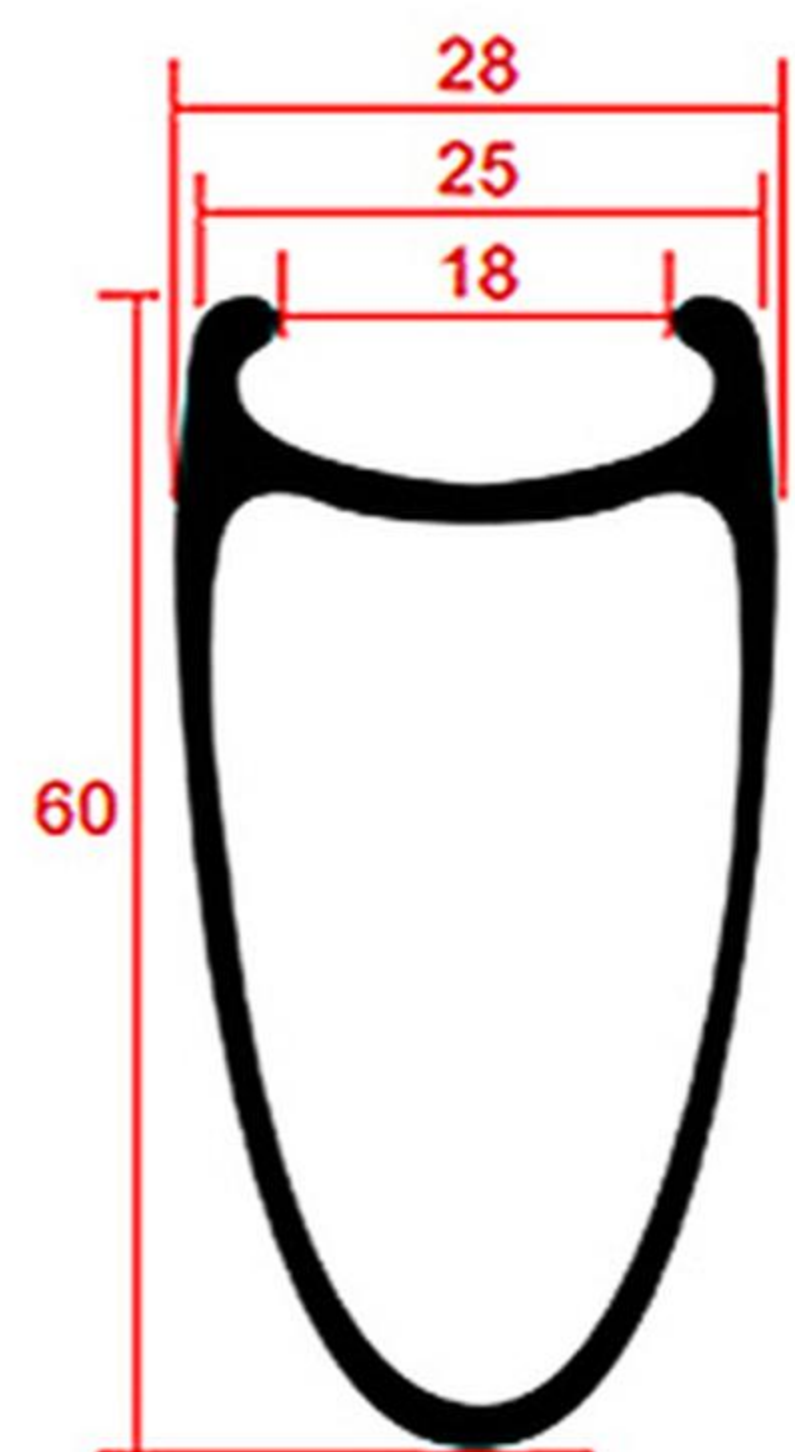

Model: R60C-25
Weight: T700:540+/-15g
T800:480+/-15g
ERD: 523

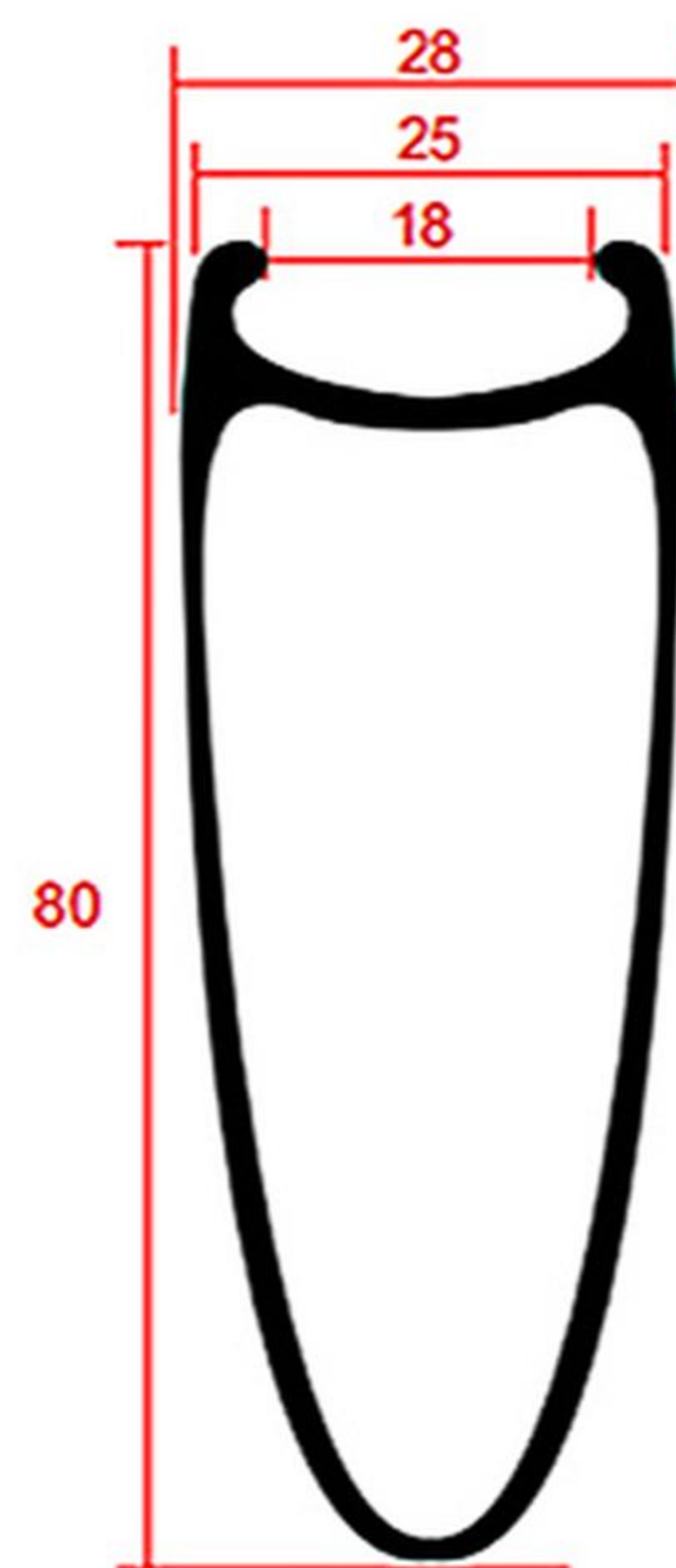

Model: R80C-25
Weight: 630+/-15g
ERD: 480

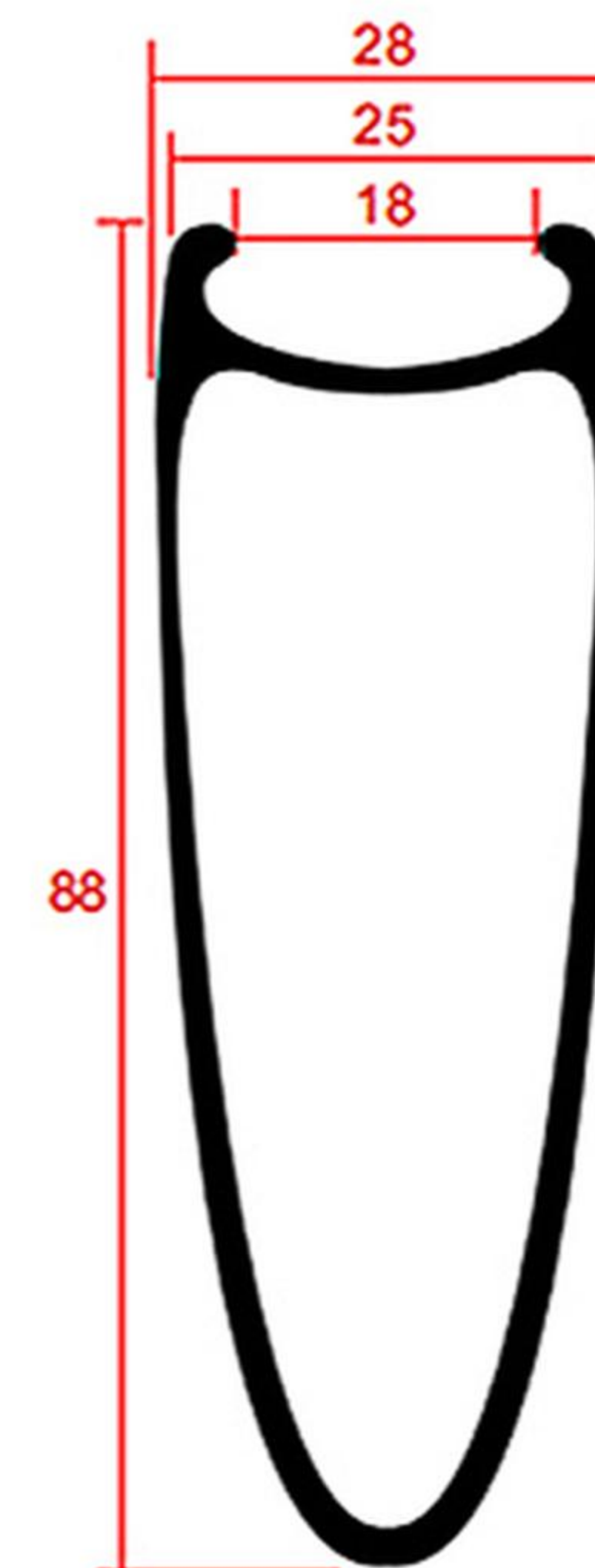

Model: R88C-25
Weight: 680+/-15g
ERD: 469

► 25mm Road Rims Tubular U-Shape

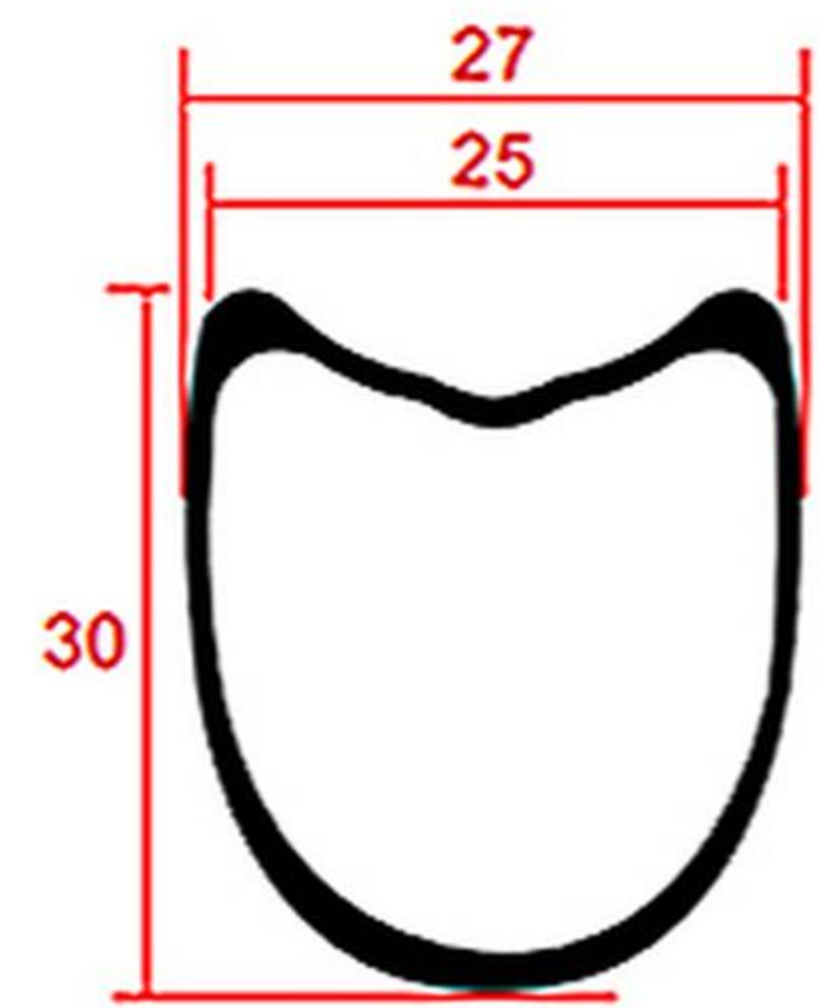

Model: R30T-25
Weight: T700:330+/-15g
T800:285+/-15g
ERD: 583

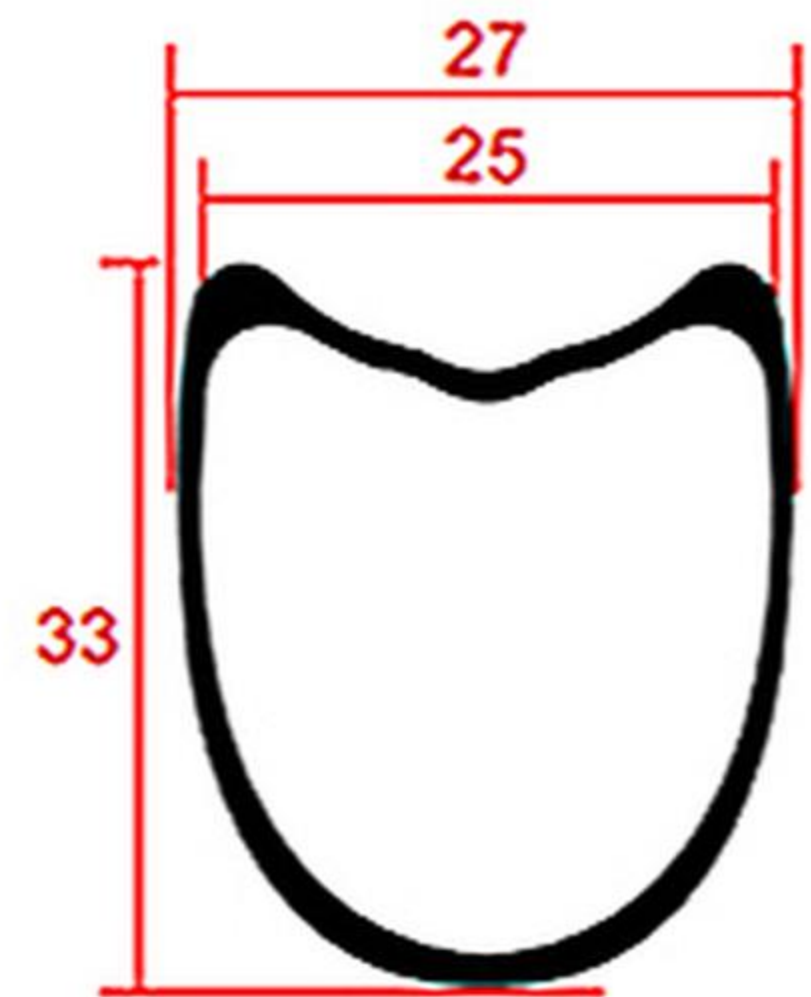

Model: R33T-25
Weight: T700:350+/-15g
T800:310+/-15g
ERD: 573.5

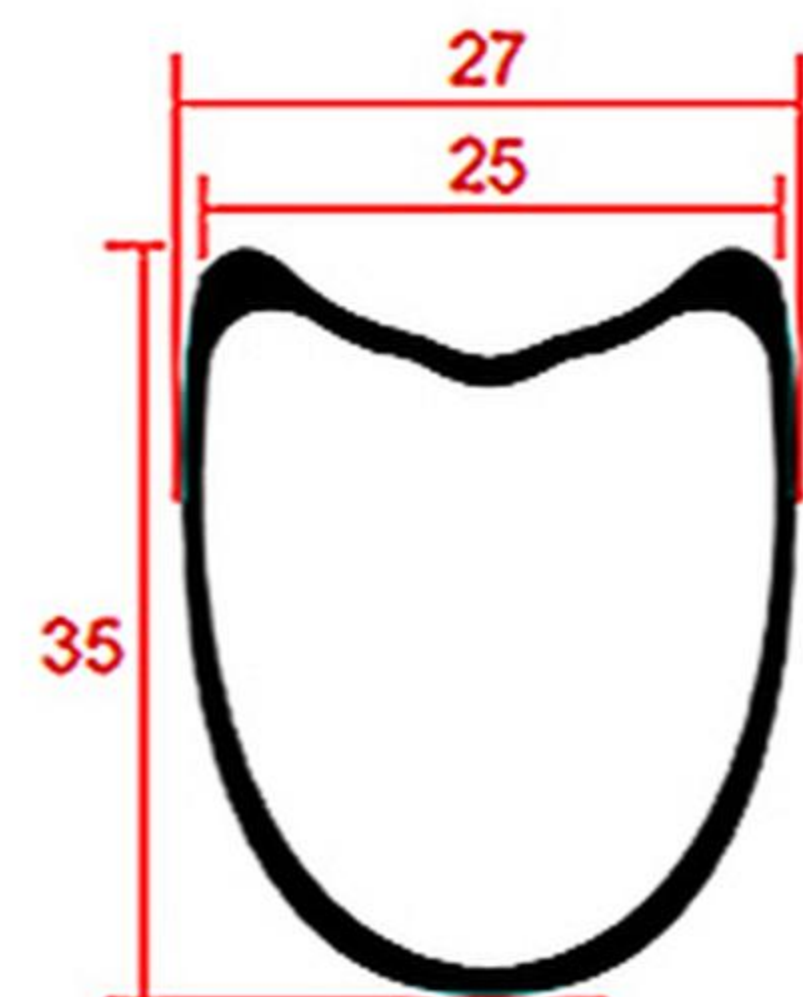

Model: R35T-25
Weight: T700:345+/-15g
T800:300+/-15g
ERD: 573

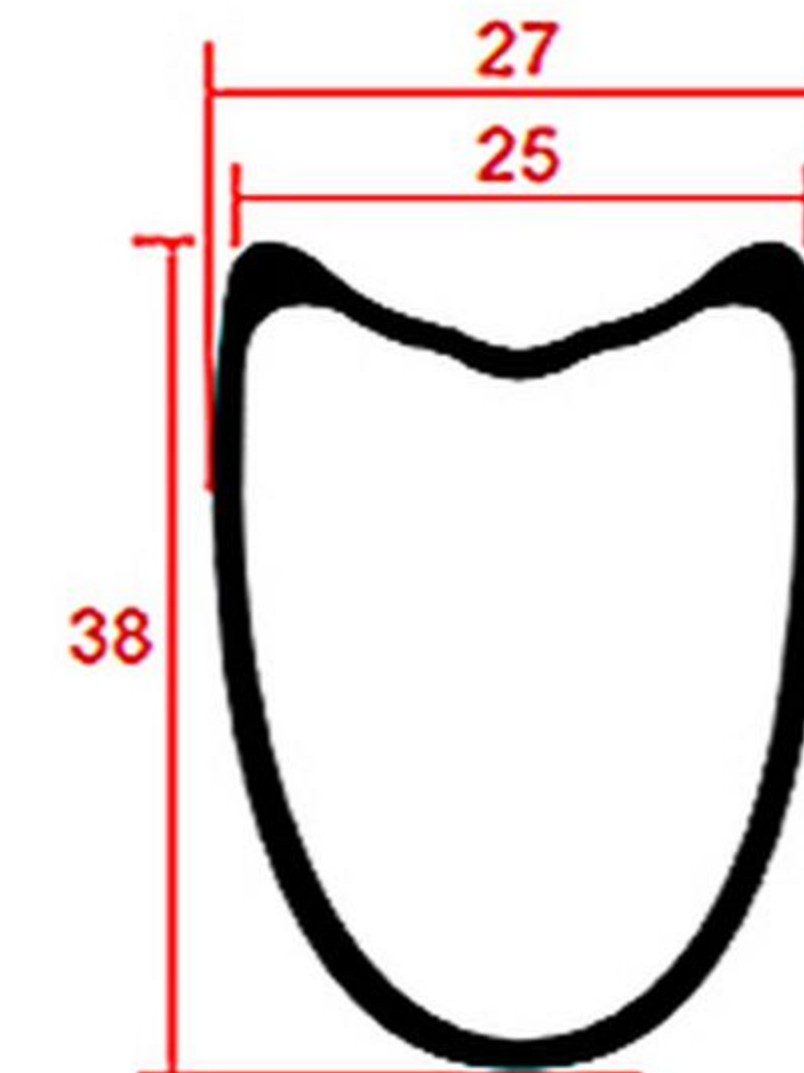

Model: R38T-25
Weight: T700:355+/-15g
T800:305+/-15g
ERD: 567

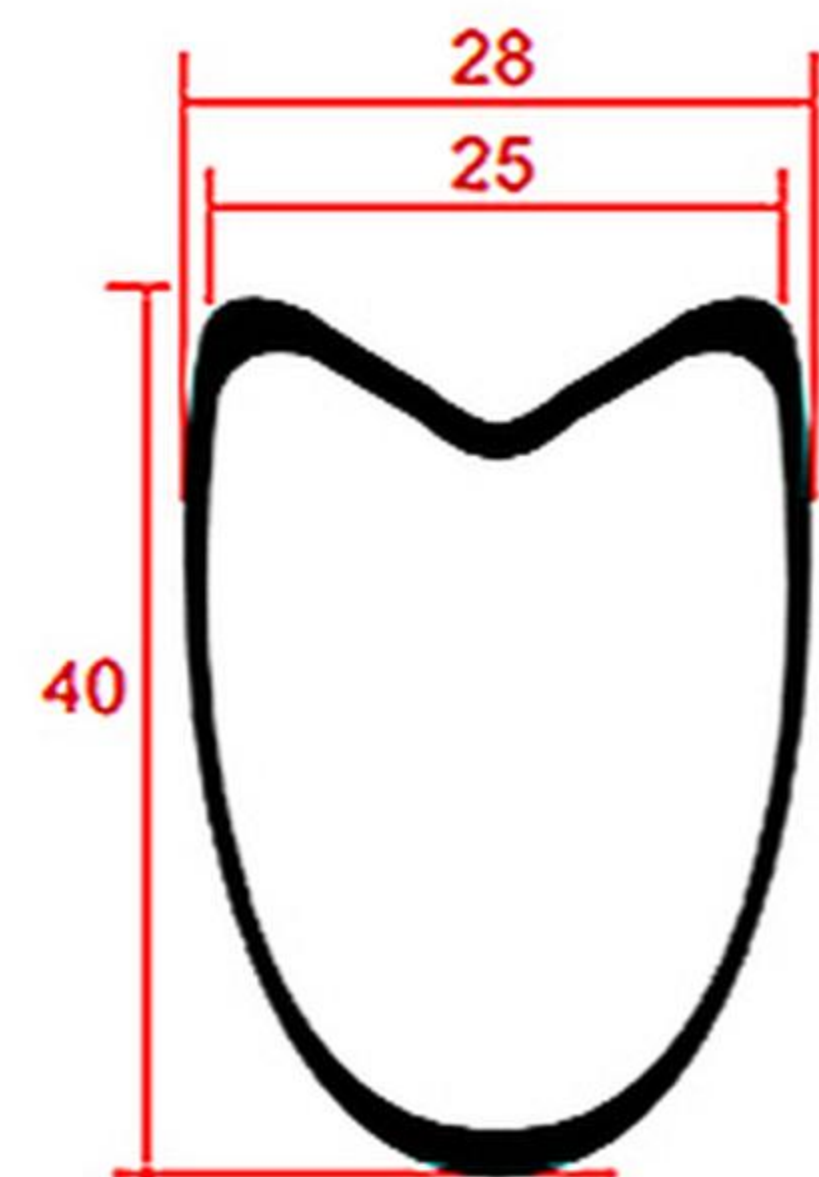

Model: R40T-25
Weight: T700:360+/-15g
T800:305+/-15g
ERD: 566.5

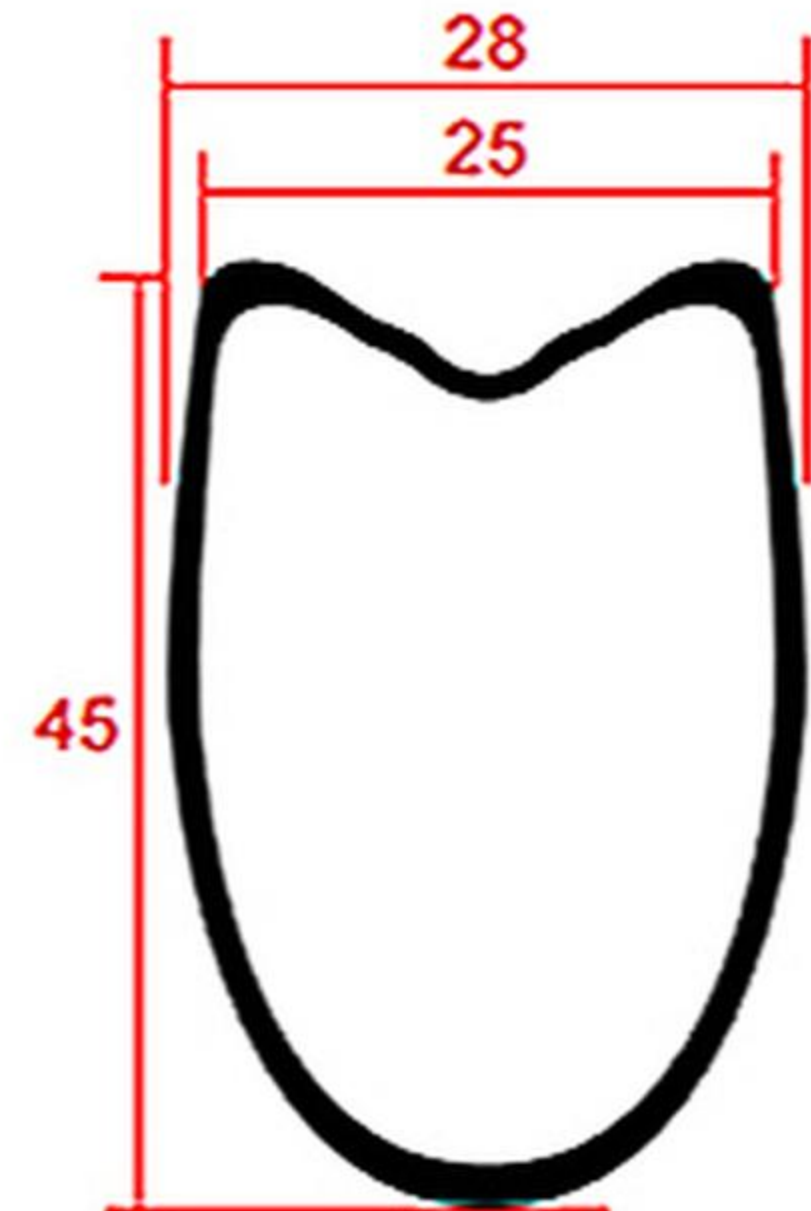

Model: R45T-25
Weight: T700:380+/-15g
T800:335+/-15g
ERD: 553

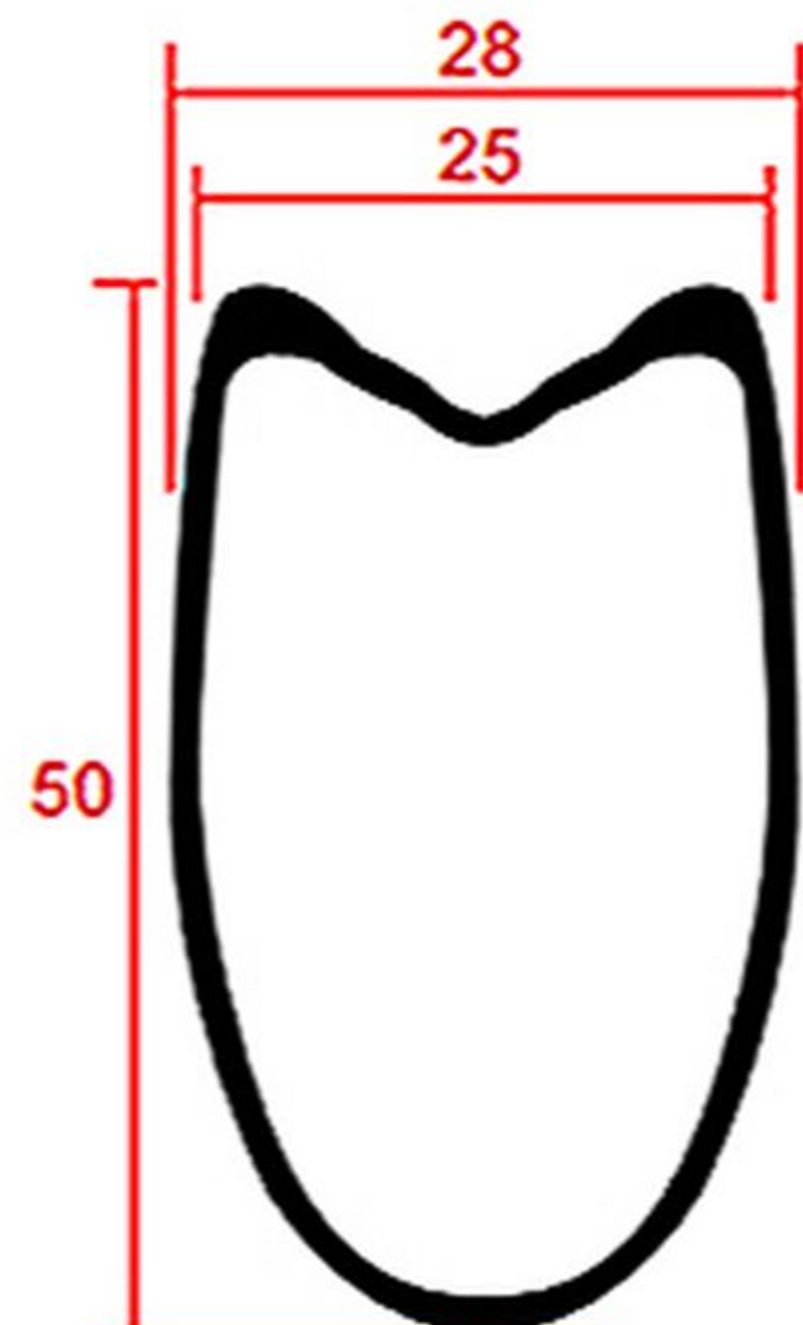

Model: R50T-25
Weight: T700:390+/-15g
T800:350+/-15g
ERD: 543

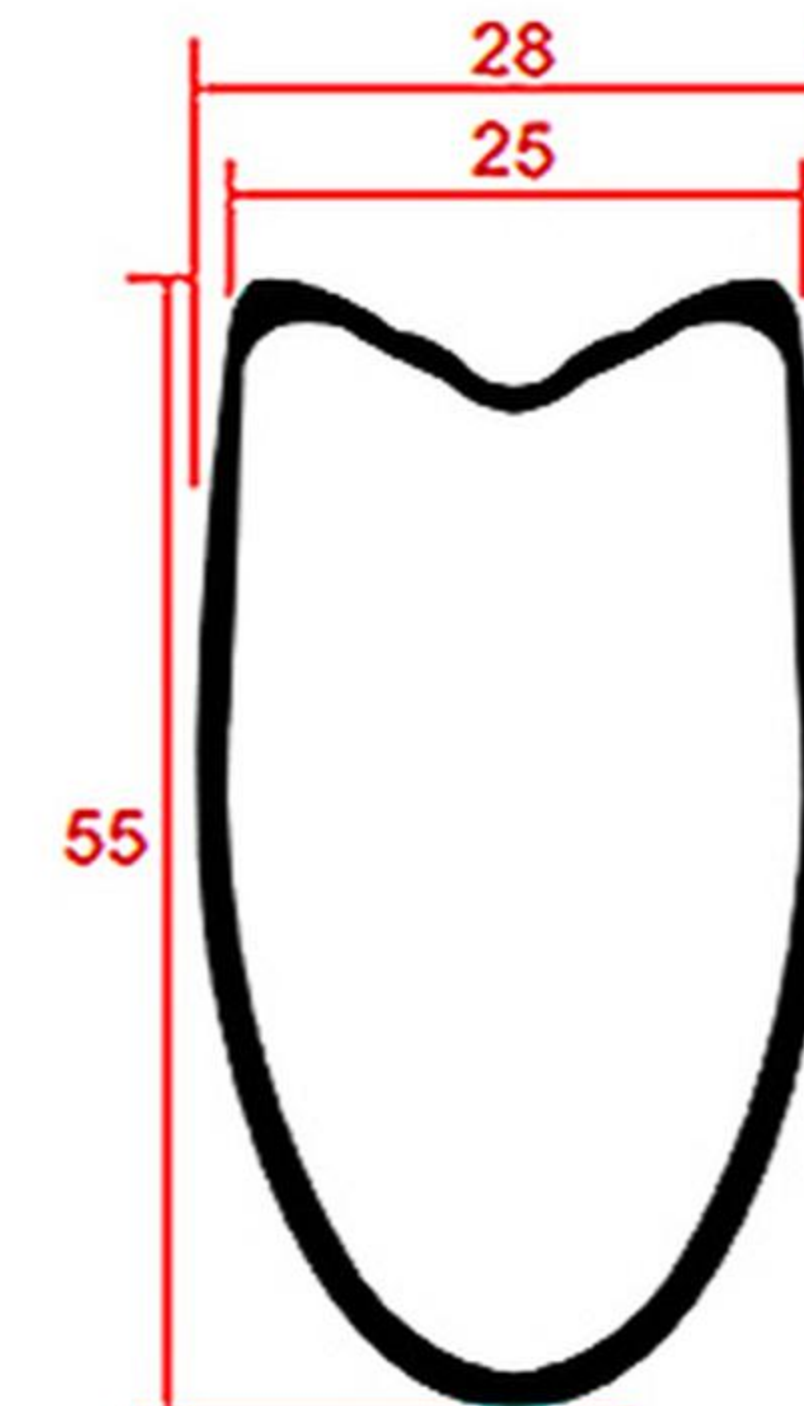

Model: R55T-25
Weight: T700:445+/-15g
T800:405+/-15g
ERD: 533

▶ 25mm Road Rims Tubular U-Shape

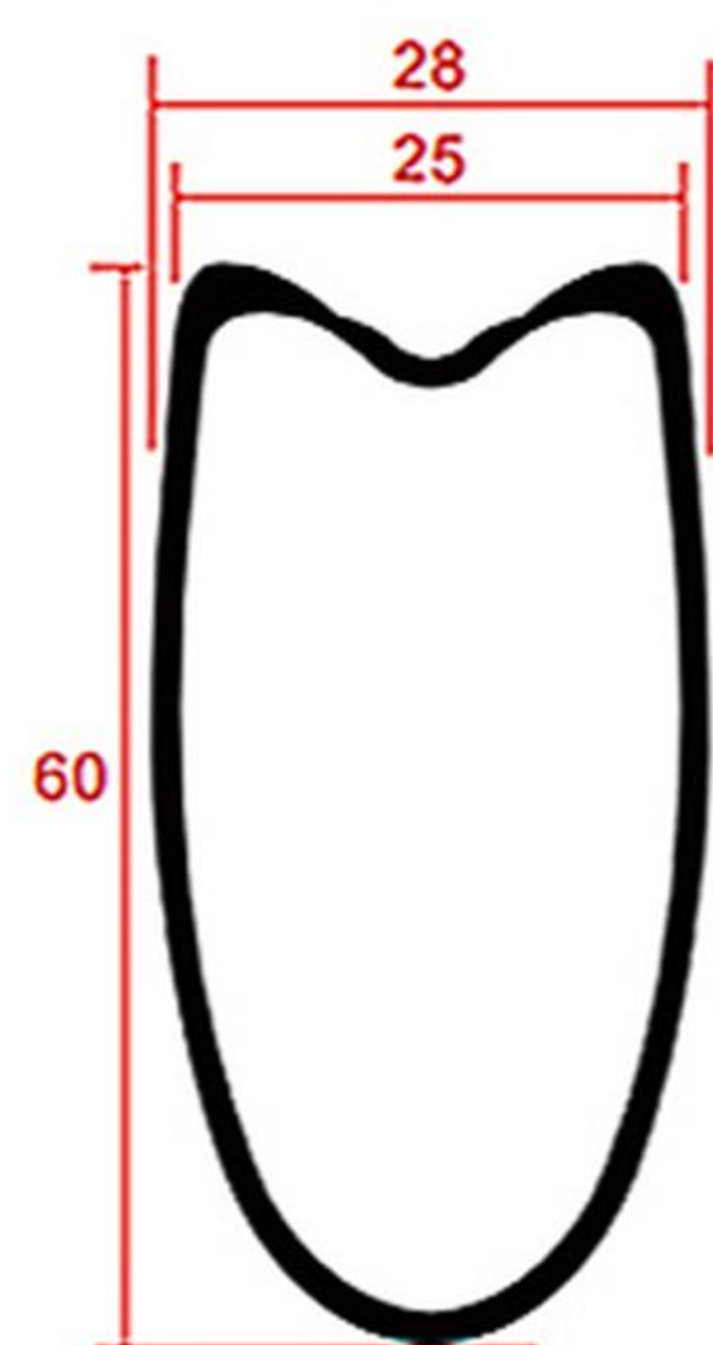

Model: R60T-25
Weight: T700:455+/-15g
 T800:420+/-15g
ERD: 523

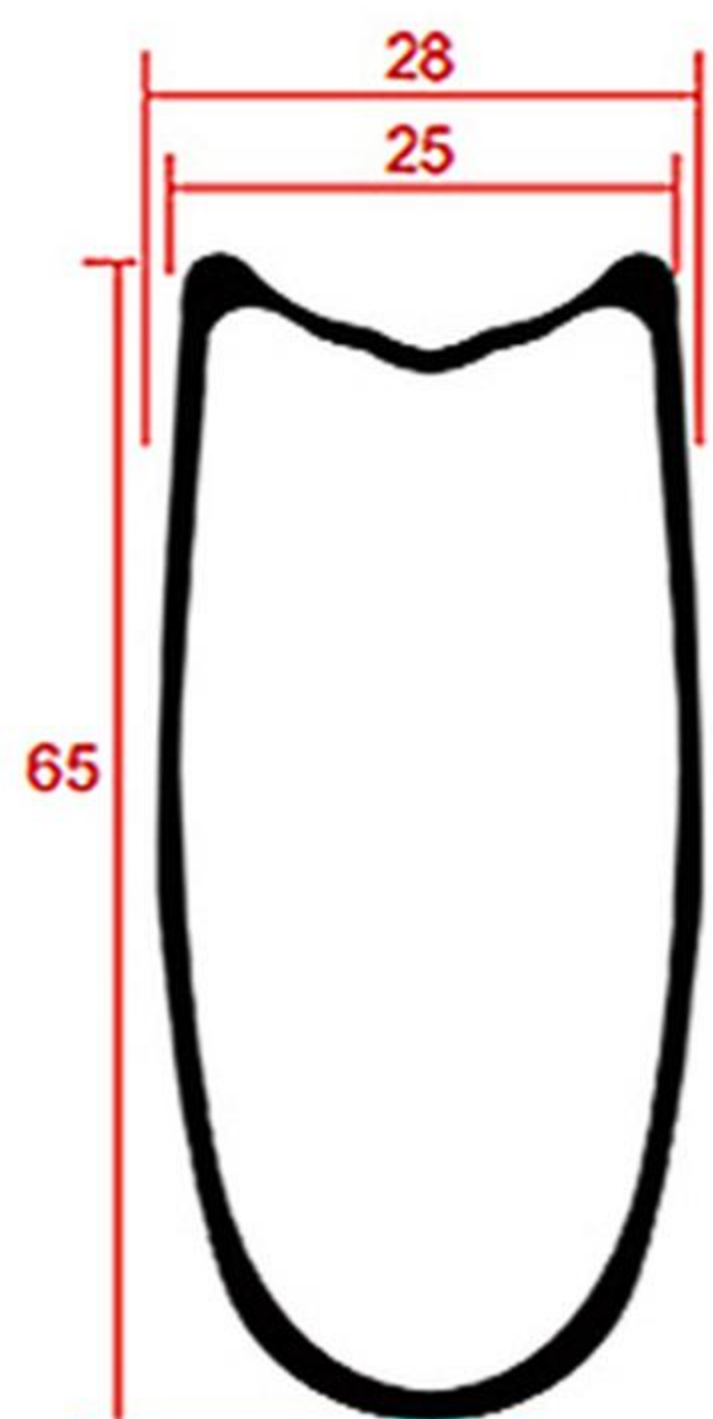

Model: R65T-25
Weight: T700:470+/-15g
 T800:430+/-15g
ERD: 509.5

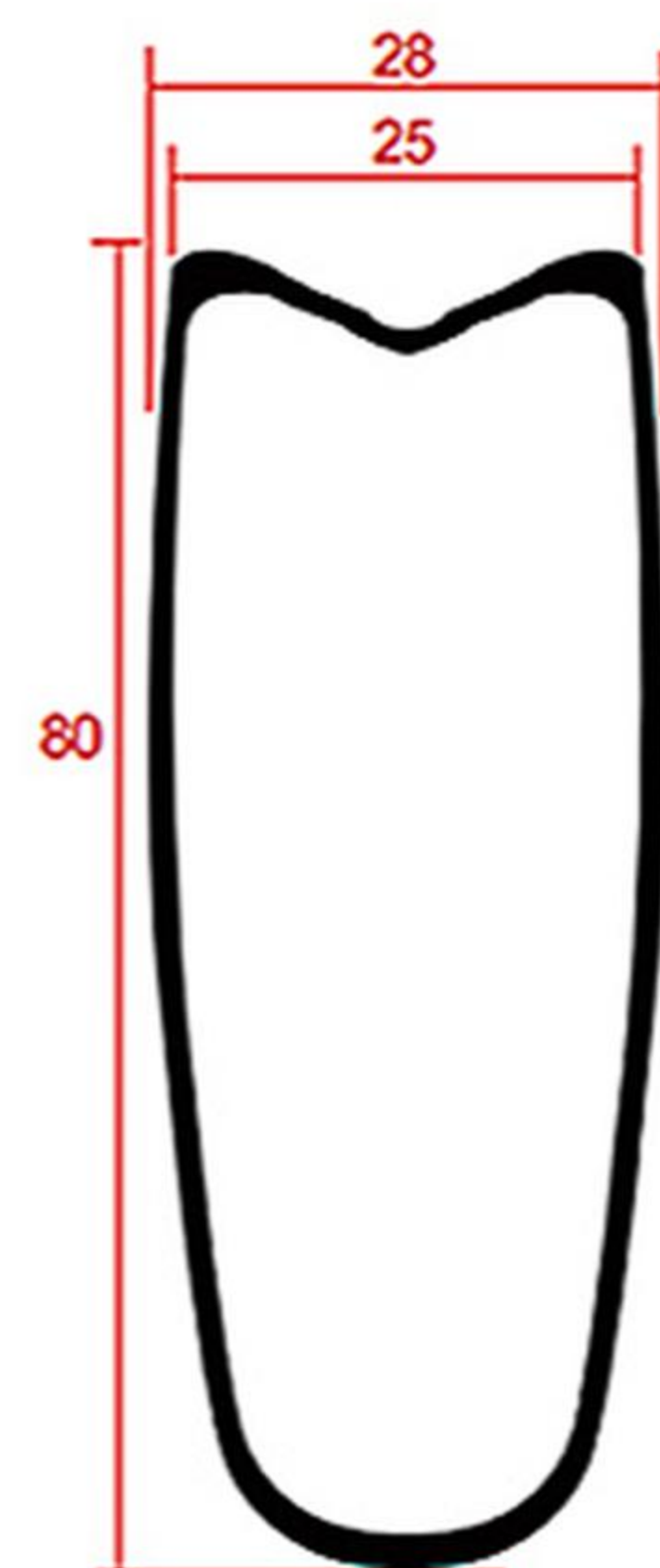

Model: R80T-25
Weight: 560+/-15g
ERD: 480

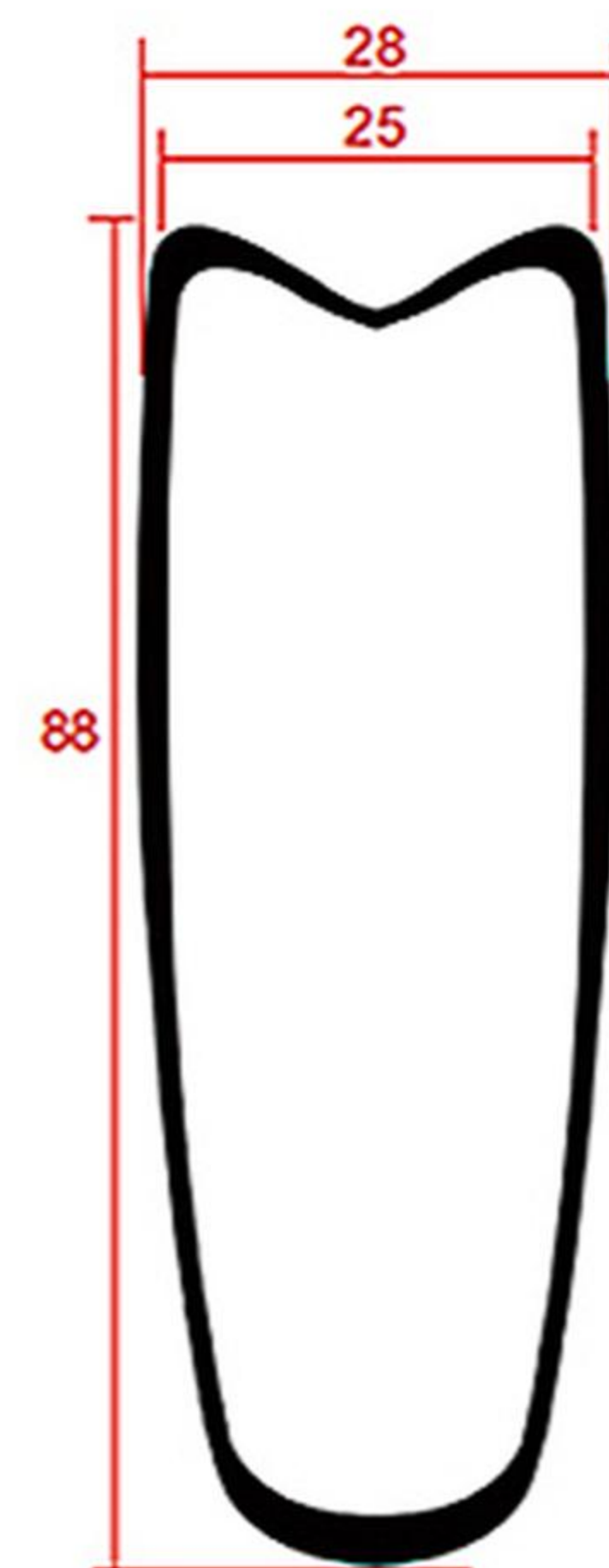

Model: R88T-25
Weight: T700:520+/-15g
 T800:480+/-15g
ERD: 469

▶ 25mm Road Rims Tubeless U-Shape

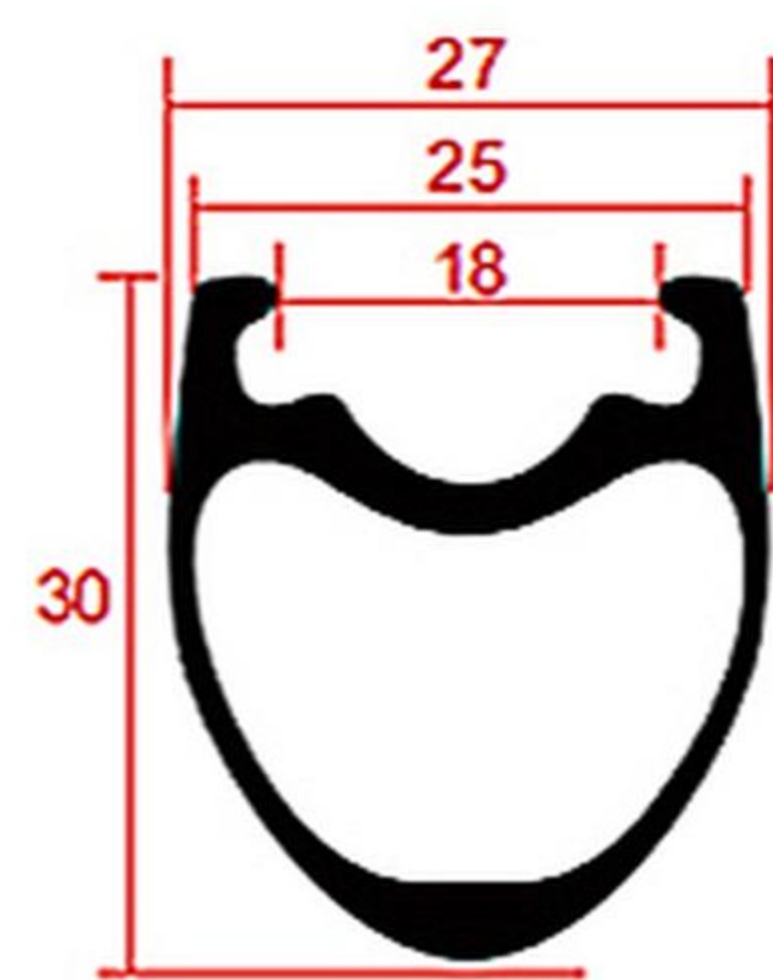

Model: R30TL-25
Weight: T700:425+/-15g
T800:365+/-15g
ERD: 583

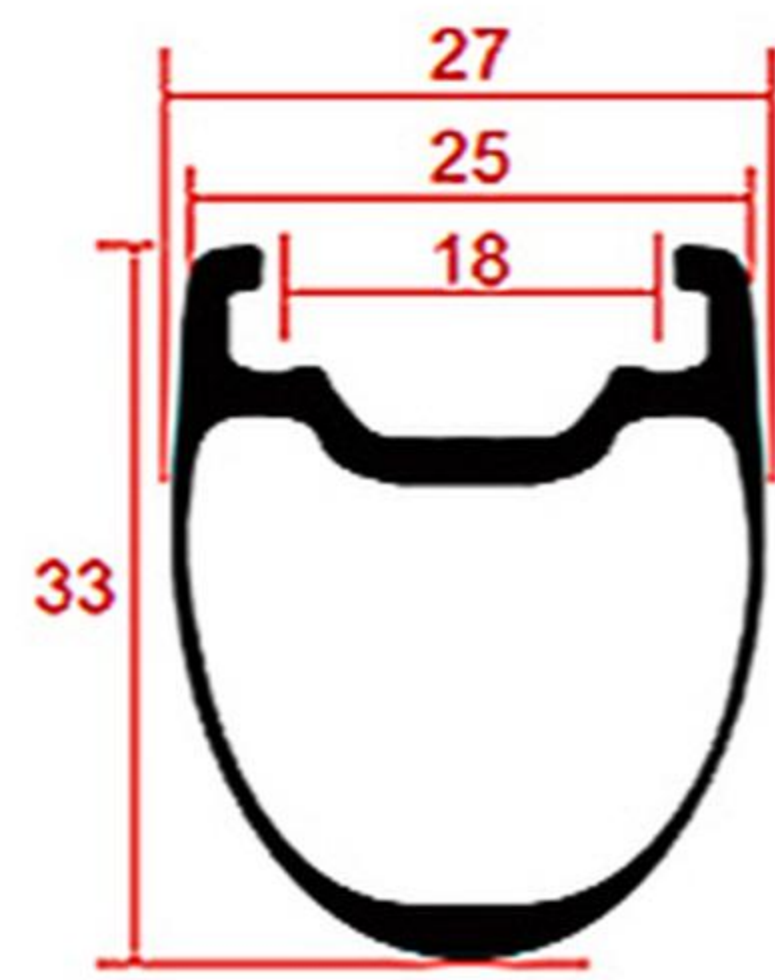

Model: R33TL-25
Weight: T700:430+/-15g
T800:390+/-15g
ERD: 573.5

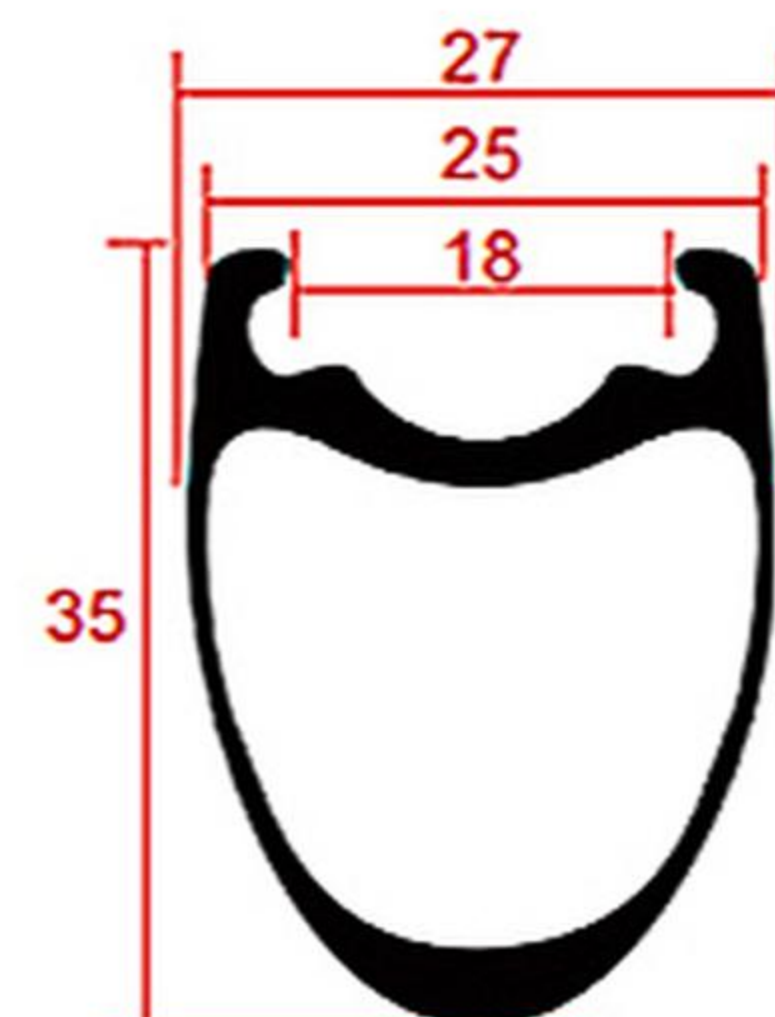

Model: R35TL-25
Weight: T700:440+/-15g
T800:375+/-15g
ERD: 573

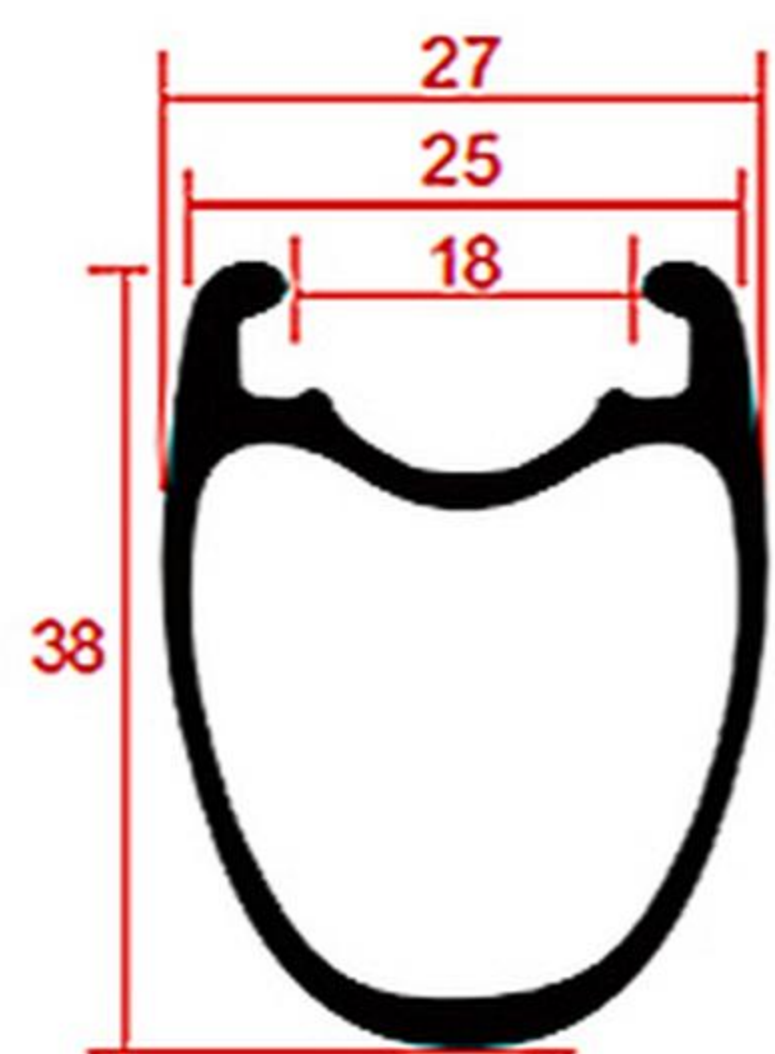

Model: R38TL-25
Weight: T700:455+/-15g
T800:390+/-15g
ERD: 567

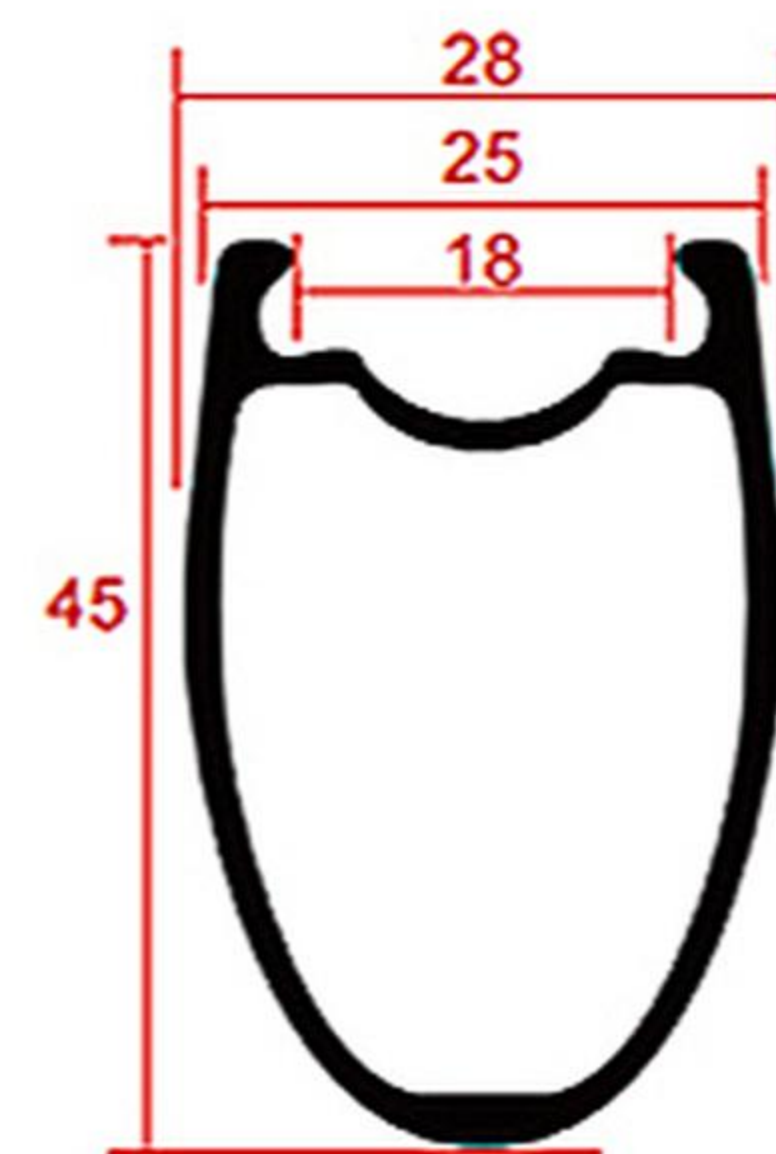

Model: R45TL-25
Weight: T700:475+/-15g
T800:415+/-15g
ERD: 553

► 25mm Road Rims Tubeless U-Shape

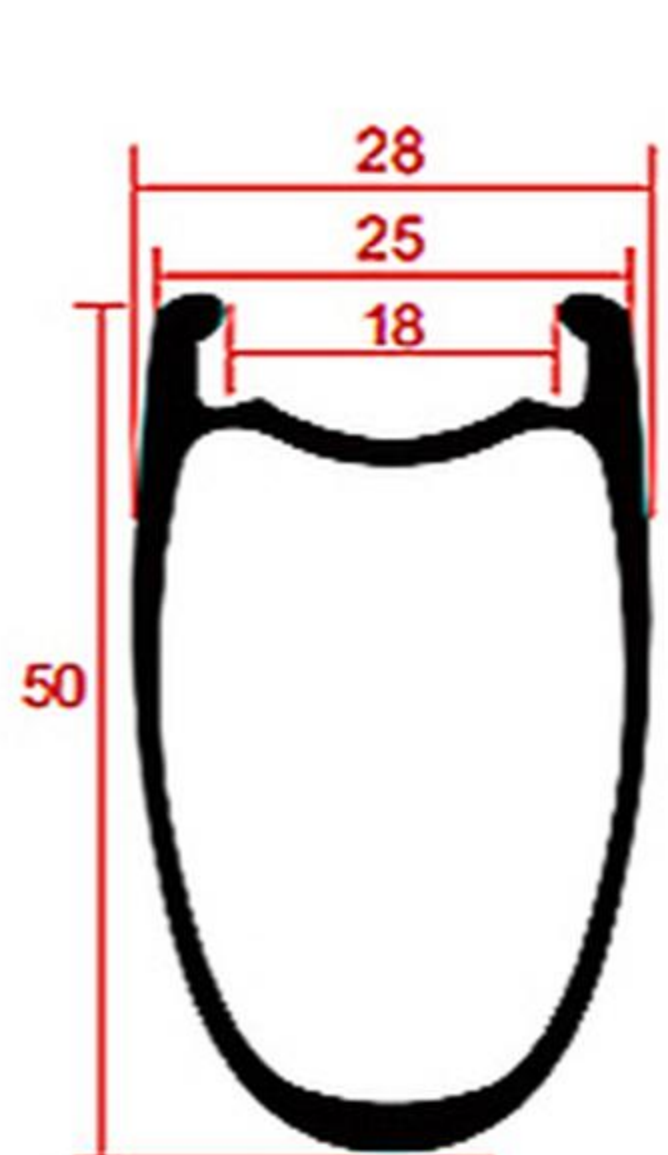

Model: R50TL-25
Weight: T700:490+/-15g
T800:430+/-15g
ERD: 543

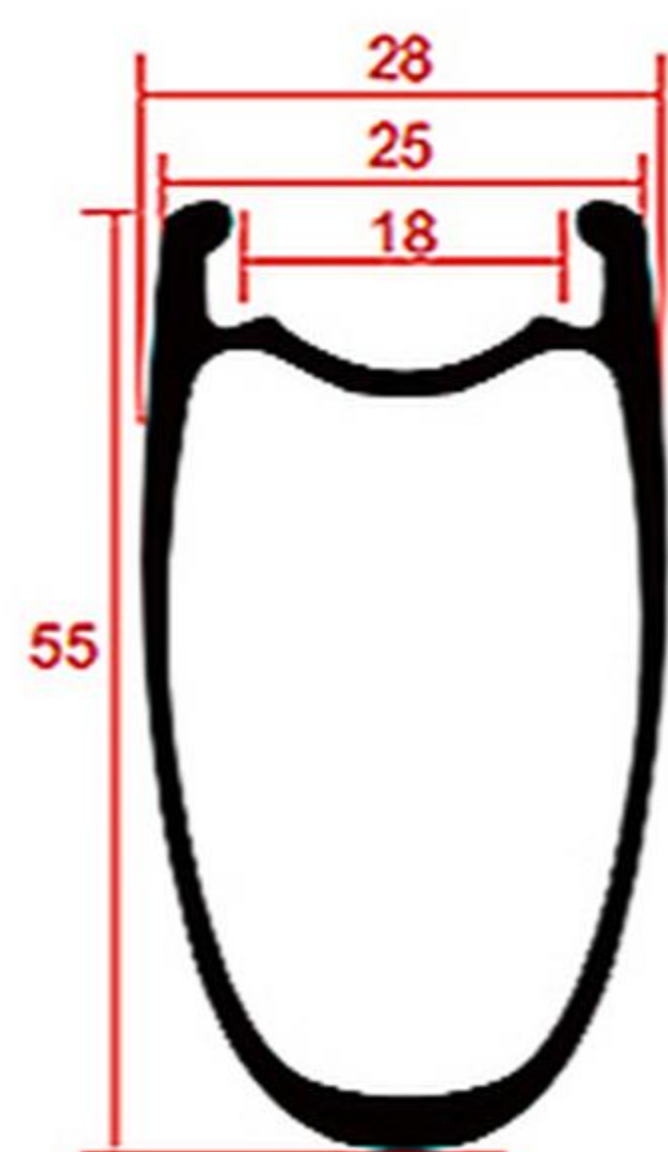

Model: R55TL-25
Weight: T700:520+/-15g
T800:460+/-15g
ERD: 533

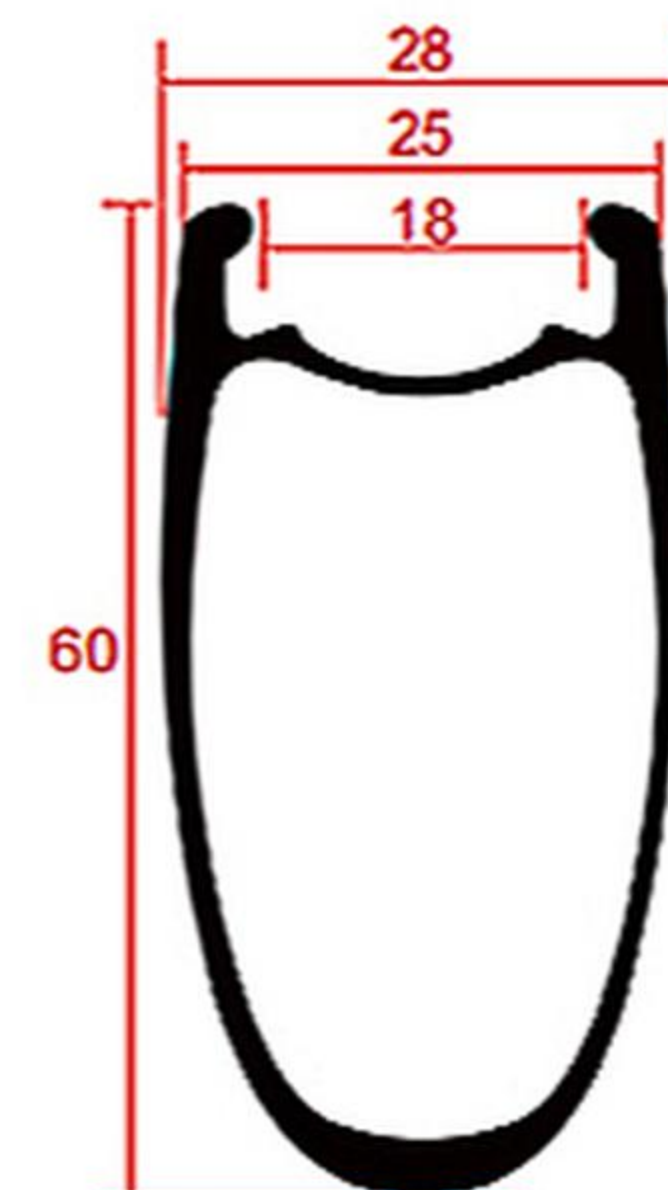

Model: R60TL-25
Weight: T700:540+/-15g
T800:480+/-15g
ERD: 523

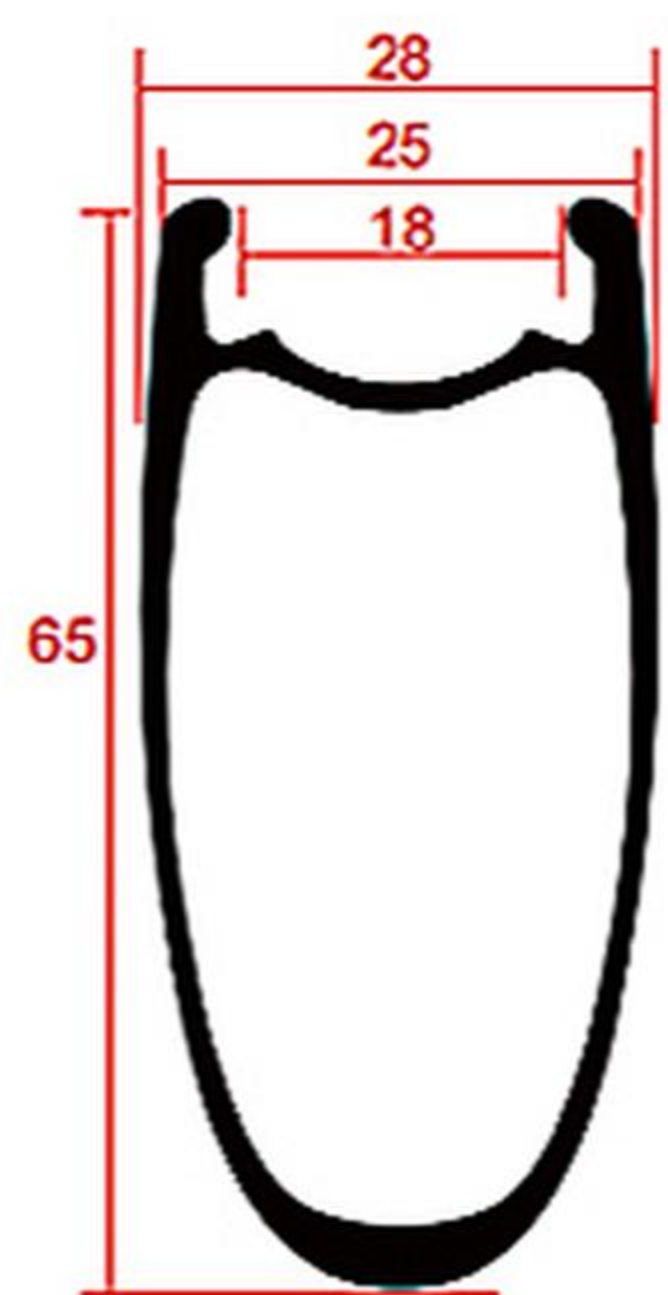

Model: R65TL-25
Weight: T700:570+/-15g
T800:490+/-15g
ERD: 509.5

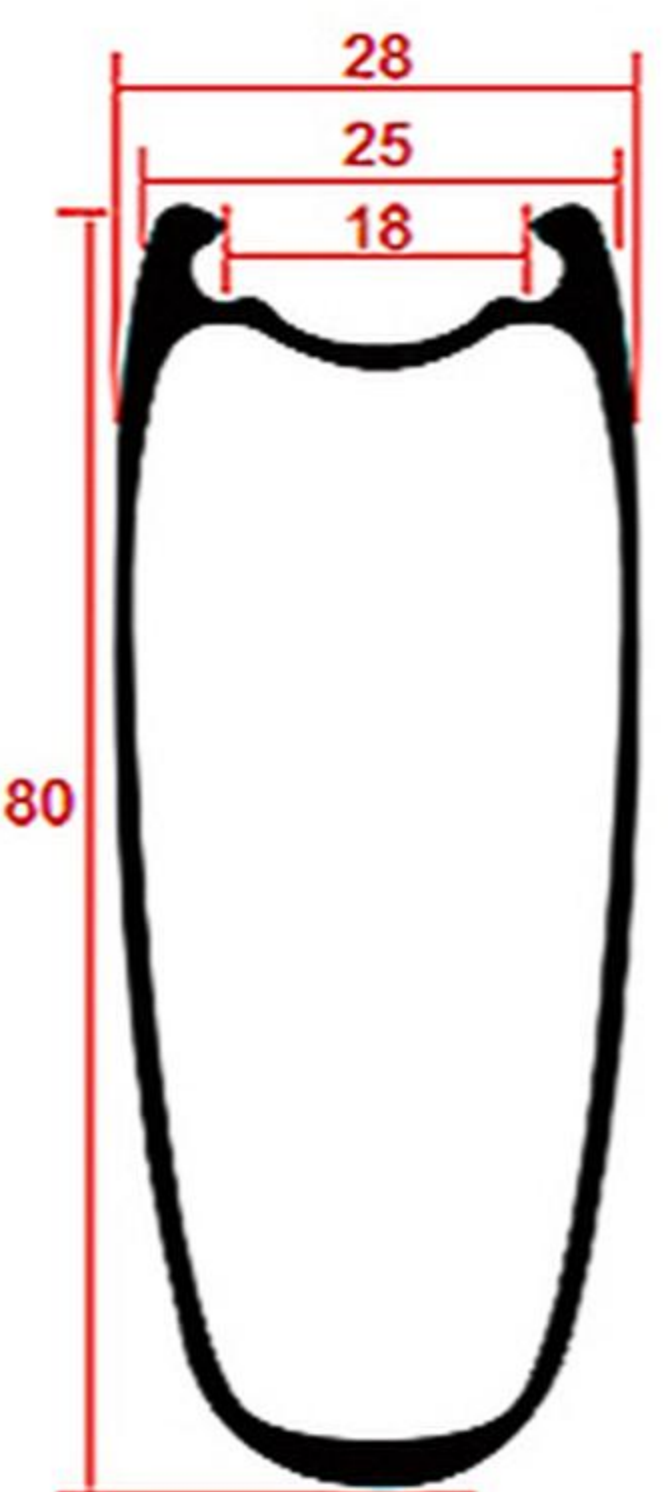

Model: R80TL-25
Weight: T700:670+/-15g
T800:640+/-15g
ERD: 480

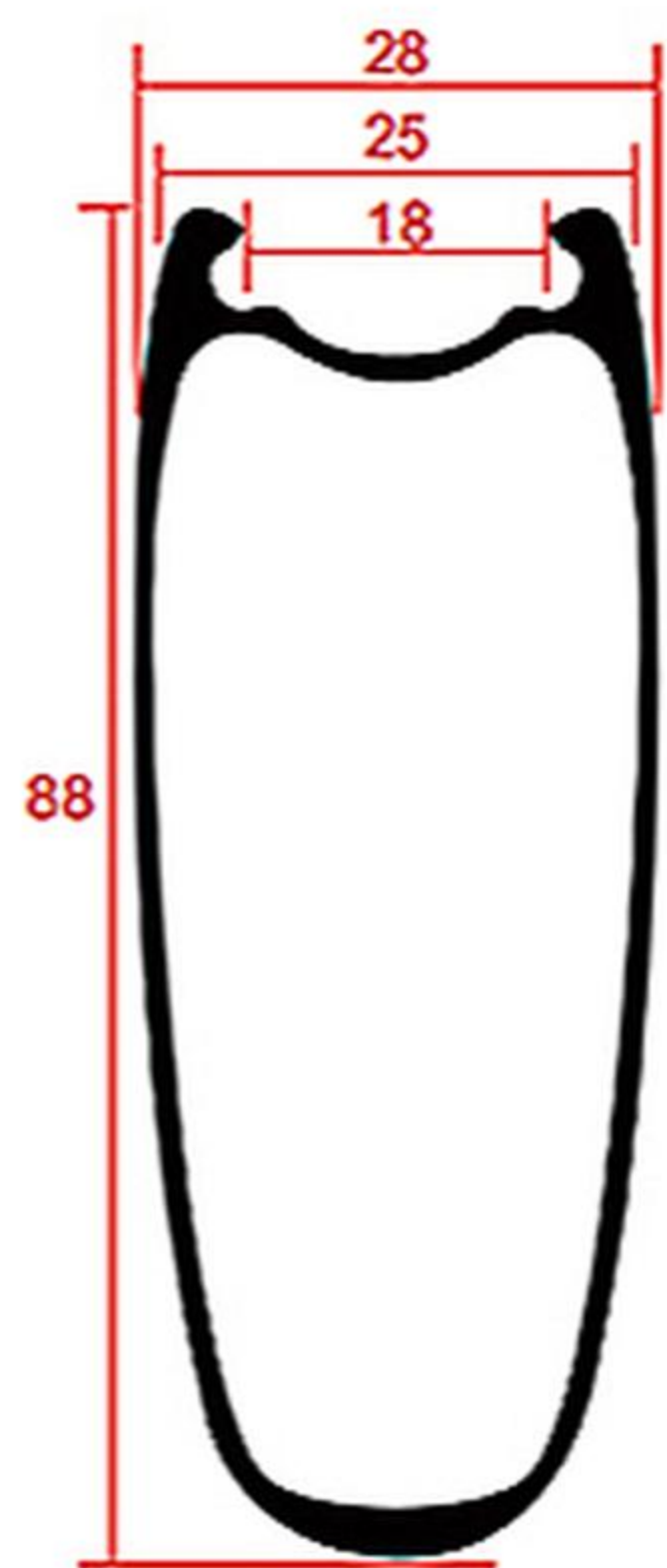

Model: R88TL-25
Weight: T700:680+/-15g
T800:650+/-15g
ERD: 469

► 26MM Width Road Rims

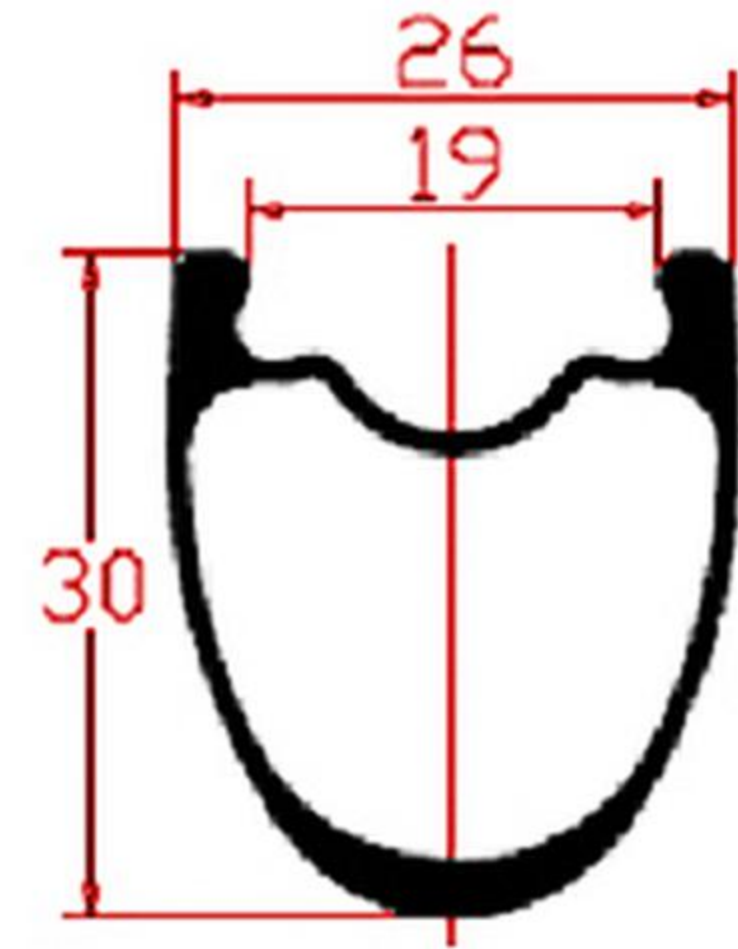

Model: R30TL-26
Weight: 400±15g(T700)
360±15g(T800)
320±15g(T800 UL)
ERD: 579mm

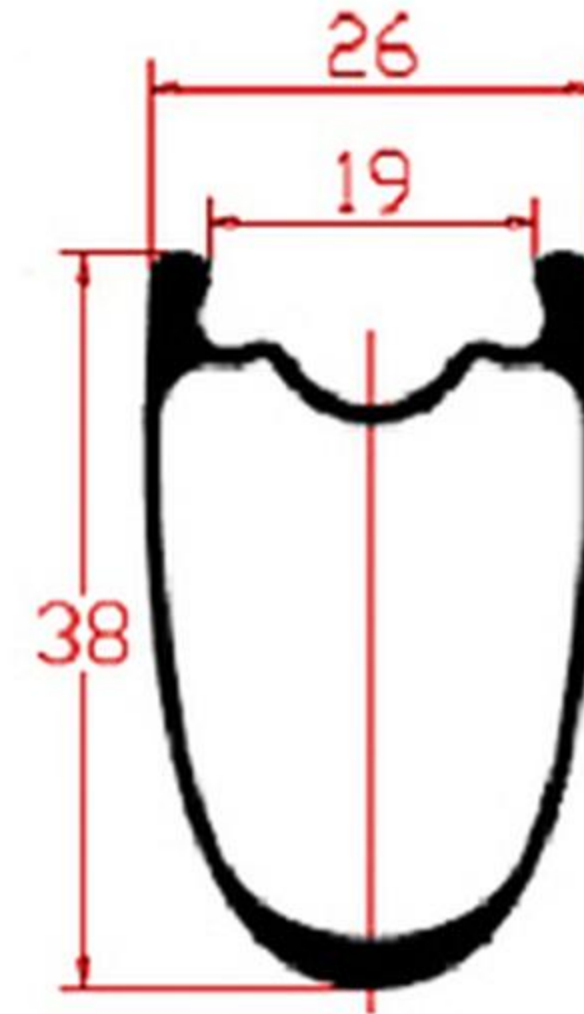

Model: R38TL-26
Weight: 440±15g(T700)
400±15g(T800)
340±15g(T800 UL)
ERD: 563mm

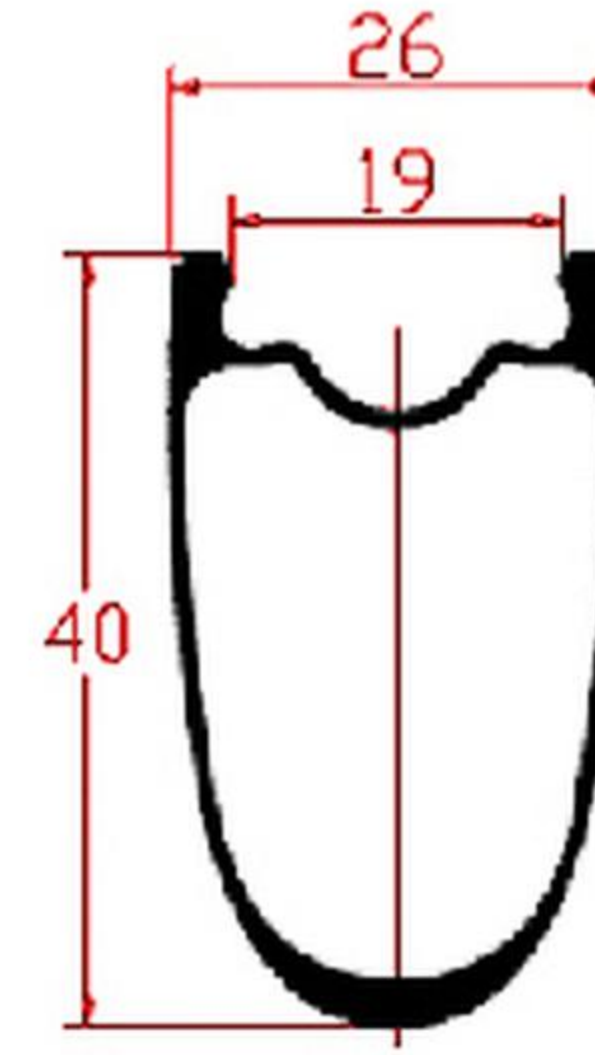

Model: R38TL-26
Weight: 440±15g(T700)
400±15g(T800)
340±15g(T800 UL)
ERD: 563mm

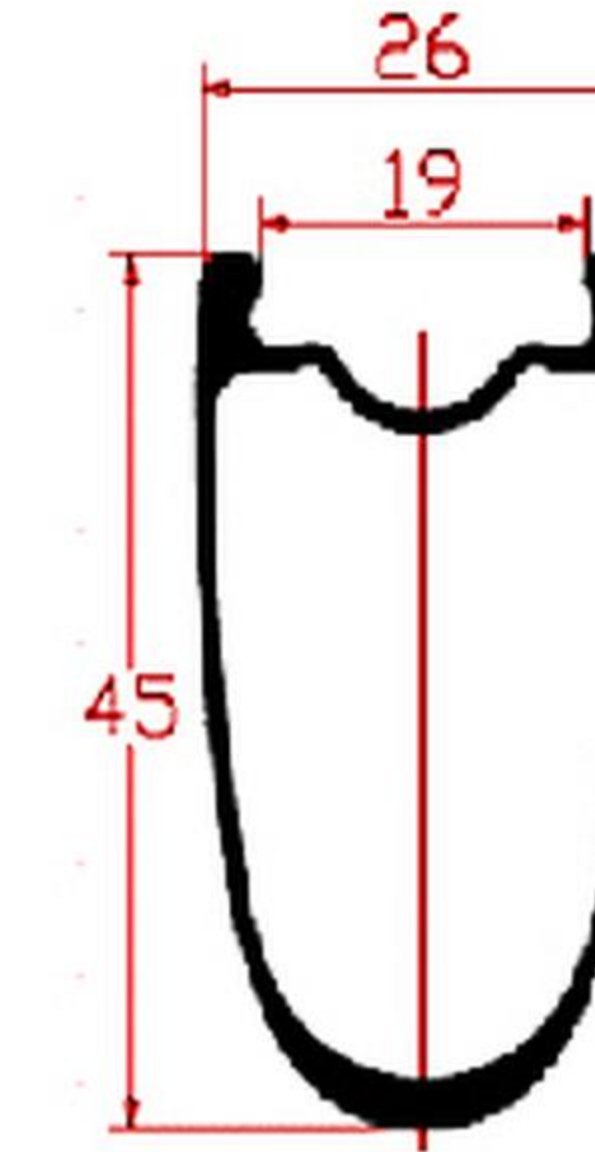

Model: R45TL-26
Weight: 460±15g(T700)
420±15g(T800)
370±15g(T800 UL)
ERD: 549mm

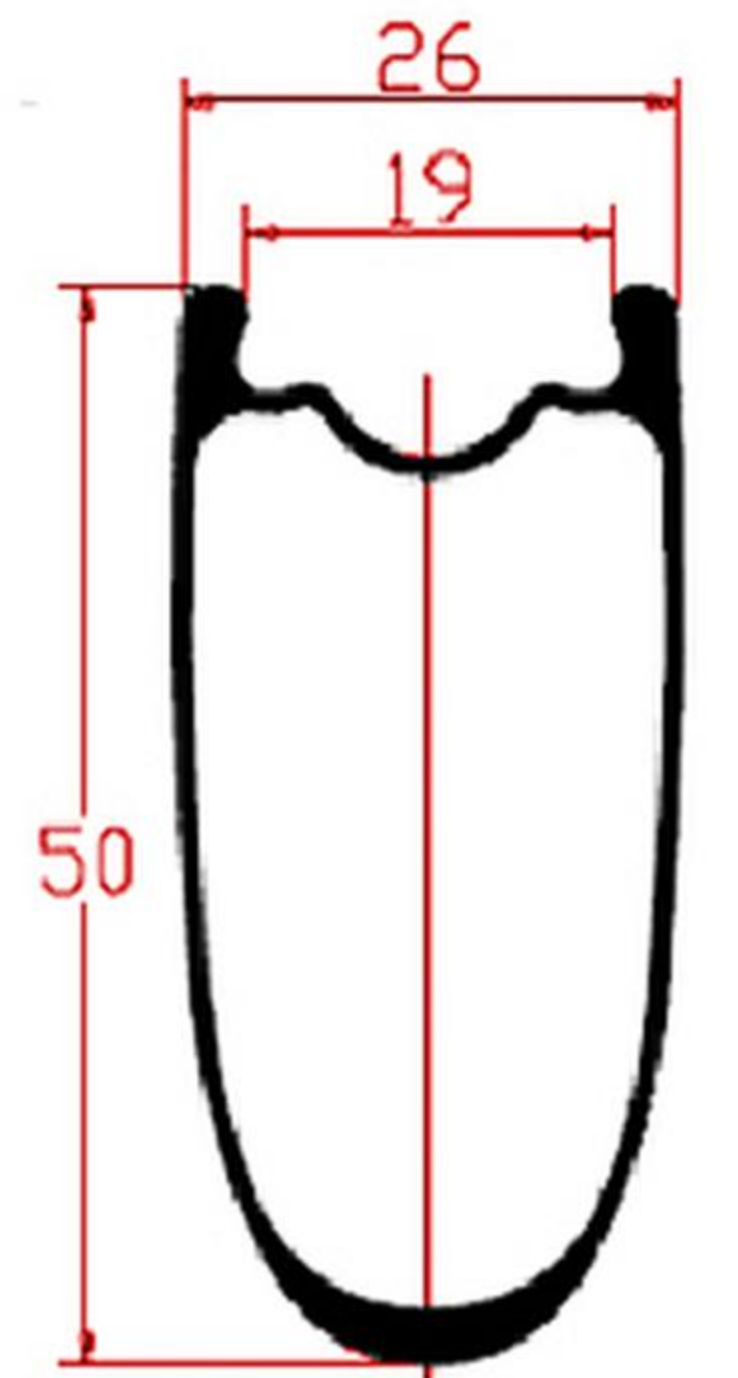

Model: R50TL-26
Weight: 4840±15g(T700)
440±15g(T800)
380±15g(T800 UL)
ERD: 539mm

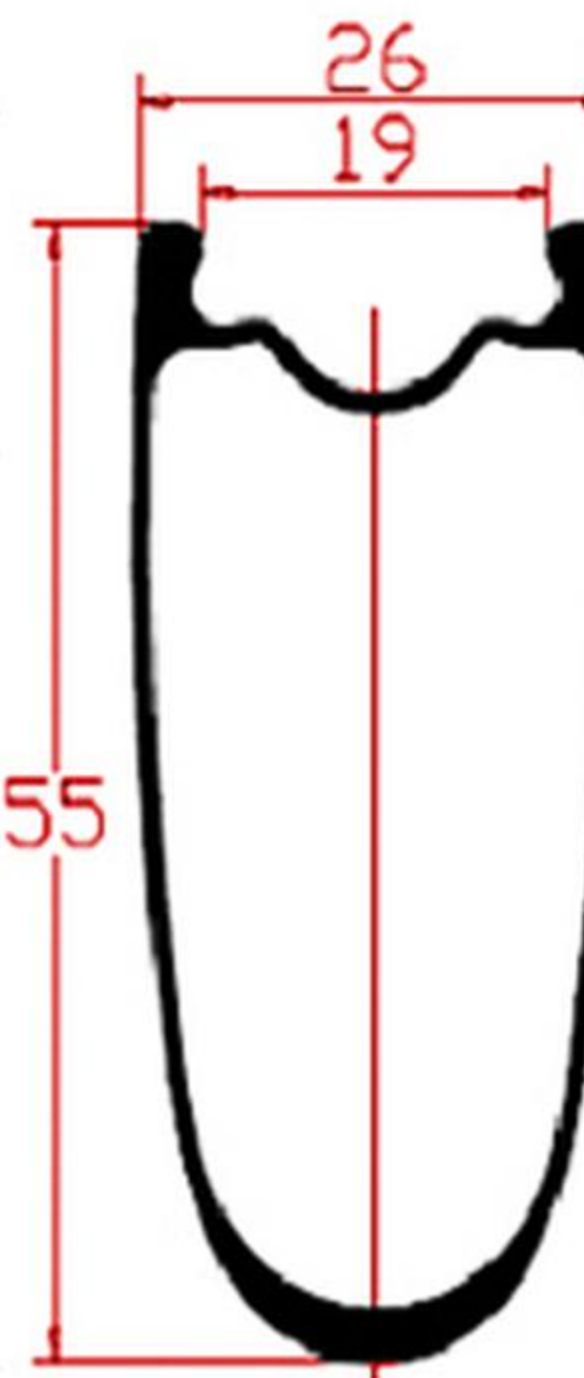

Model: R55TL-26
Weight: 520±15g(T700)
480±15g(T800)
420±15g(T800 UL)
ERD: 529mm

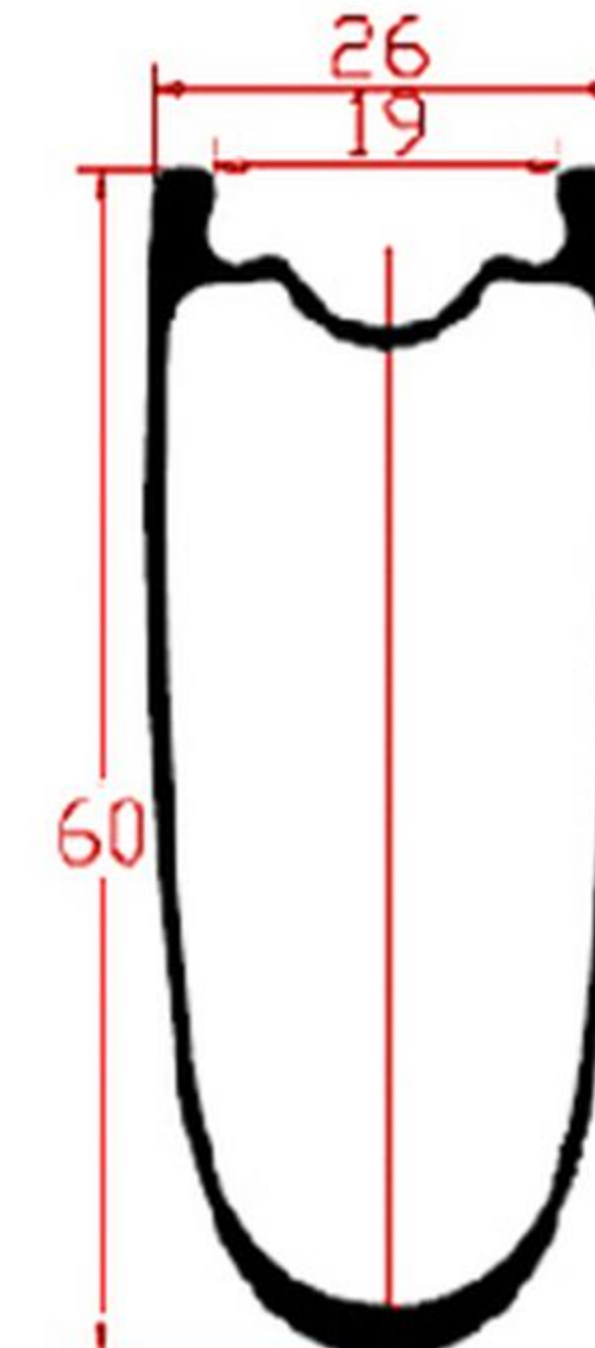

Model: R60TL-26
Weight: 540±15g(T700)
500±15g(T800)
450±15g(T800 UL)
ERD: 519mm

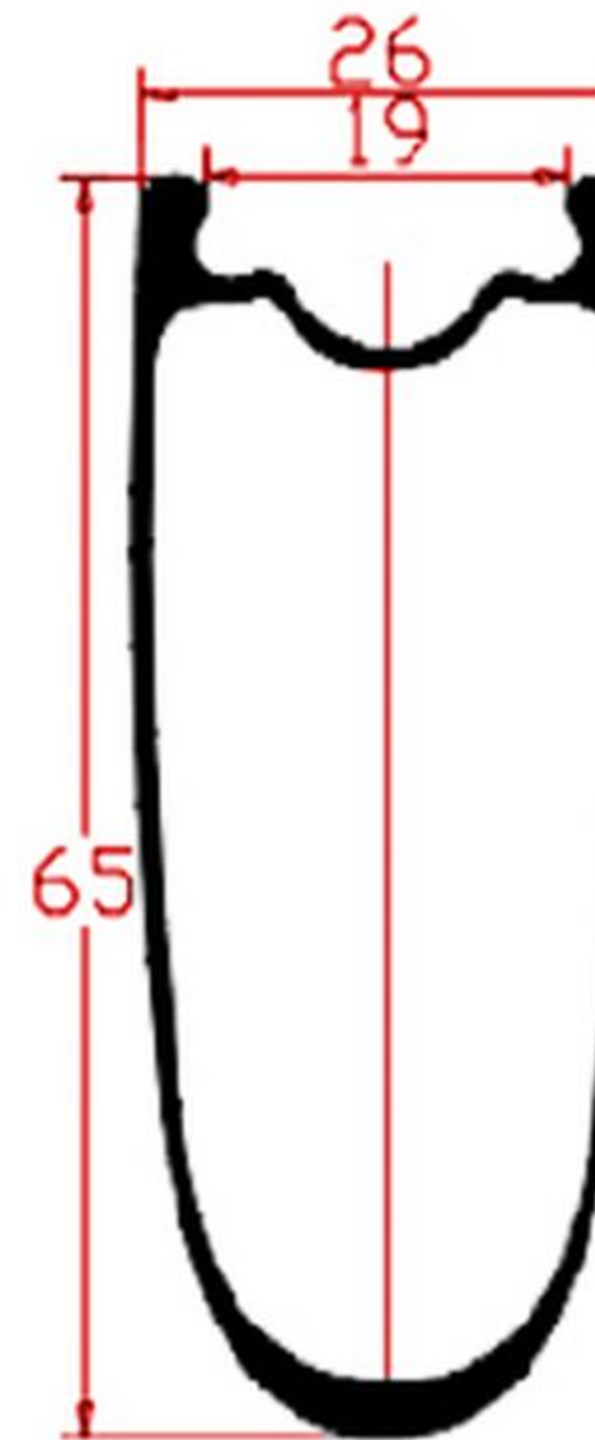

Model: R65TL-26
Weight: 560±15g(T700)
520±15g(T800)
480±15g(T800 UL)
ERD: 509mm

► 28mm Road Rims Tubular U-Shape

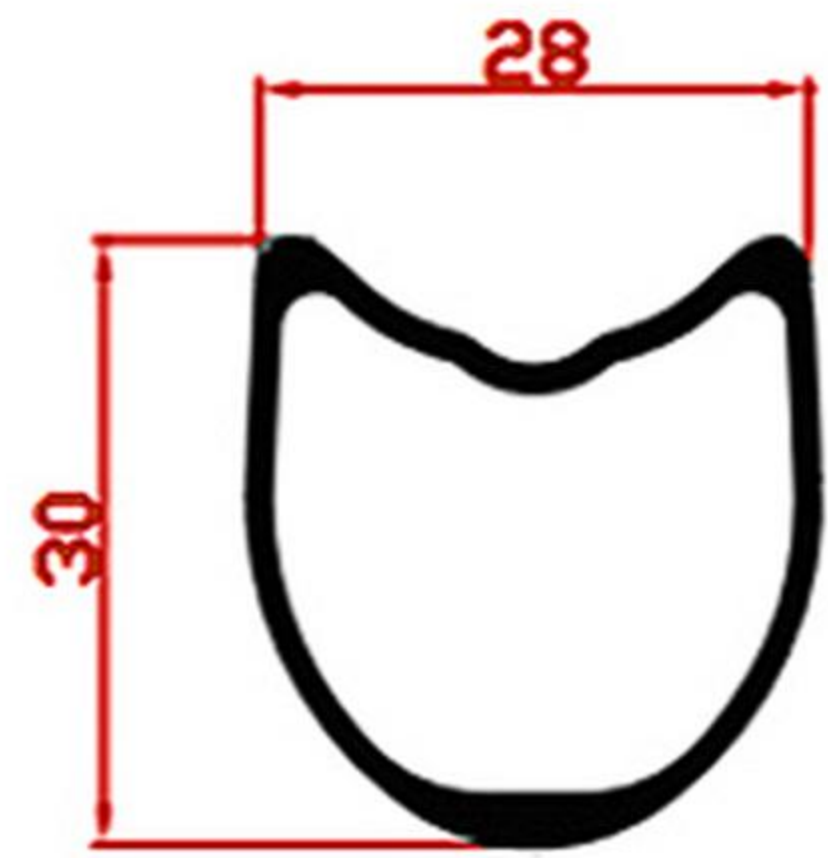

Model: R30T-28
Weight: T700: 340±15g
T800: 310±10g
ERD: 583

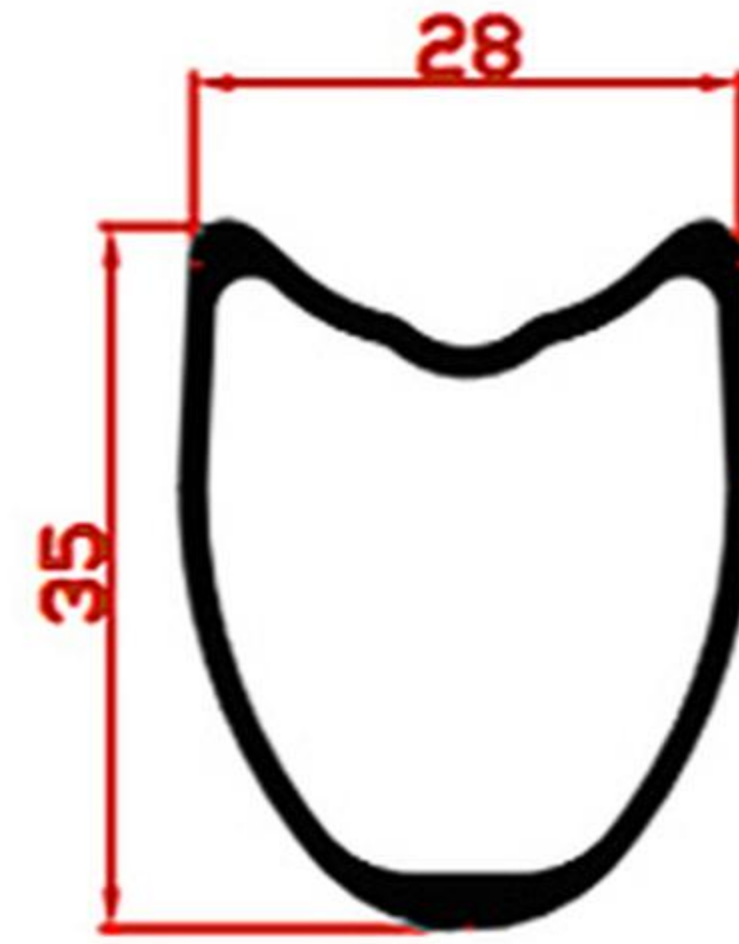

Model: R35T-28
Weight: T700: 360±15g
T800: 330±10g
ERD: 573

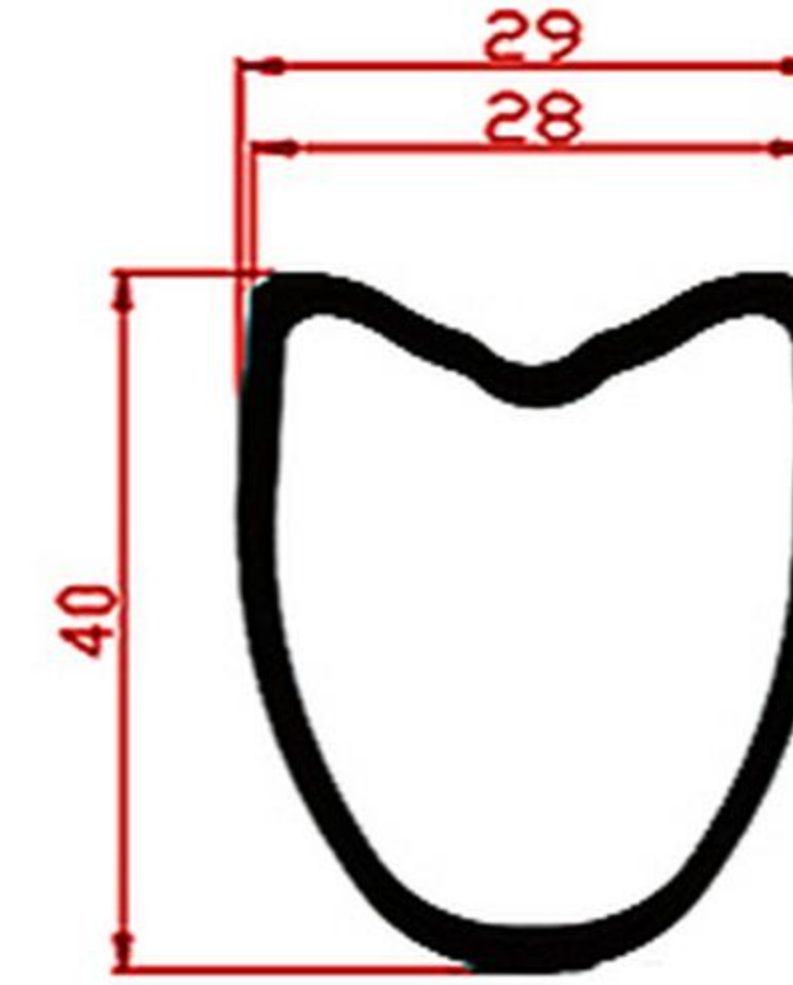

Model: R40T-28
Weight: T700: 380±15g
T800: 350±10g
ERD: 564

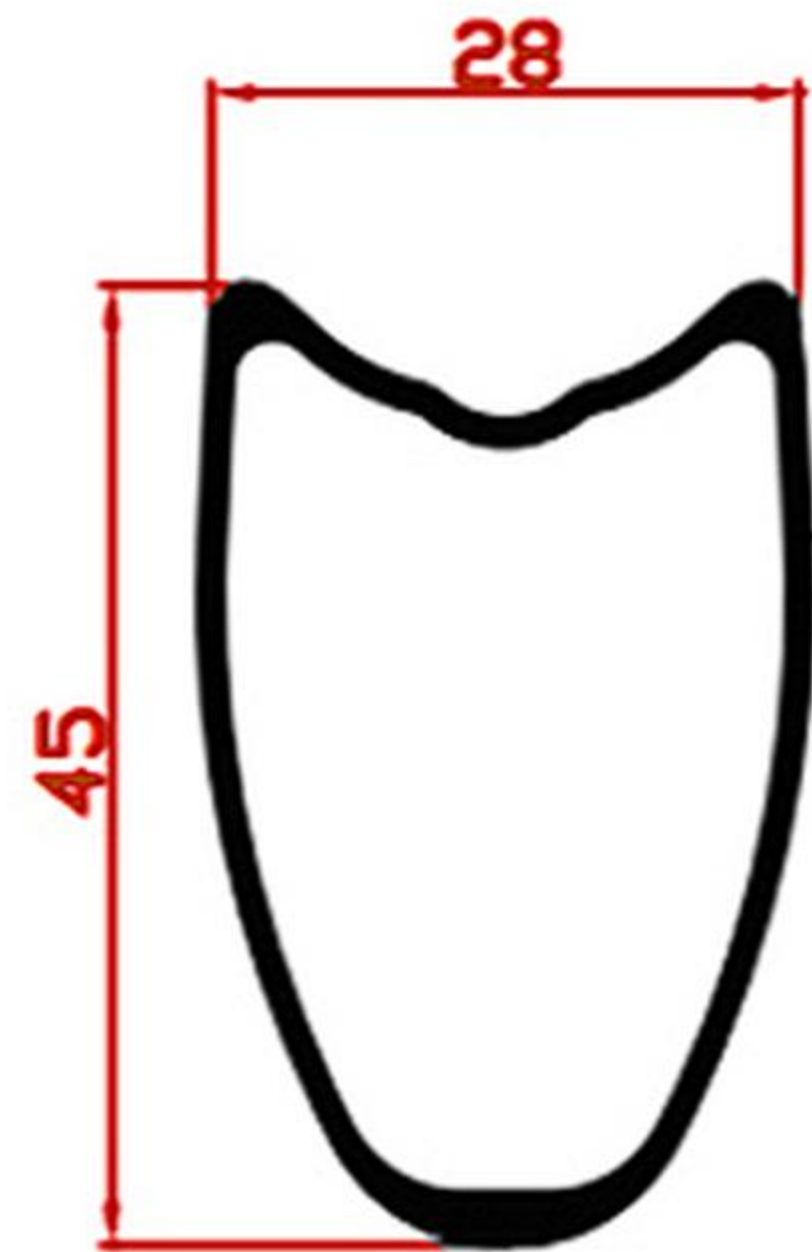

Model: R45T-28
Weight: T700: 400±15g
T800: 360±15g
ERD: 553

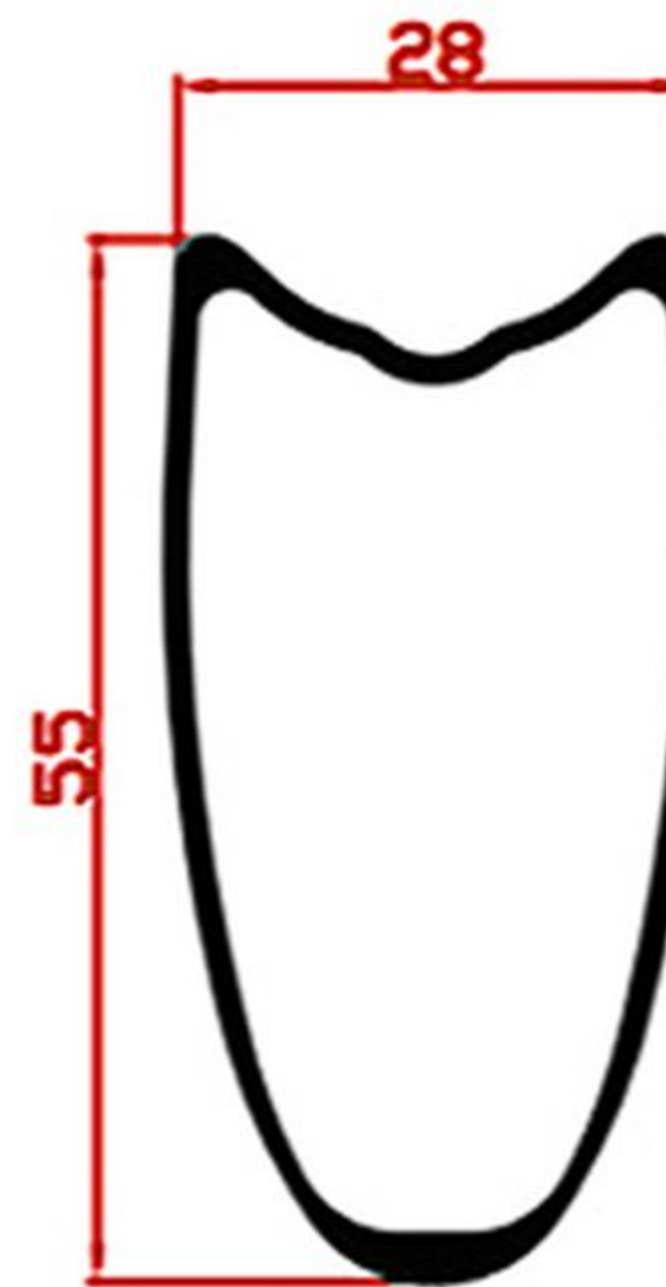

Model: R55T-28
Weight: T700: 440±15g
T800: 400±10g
ERD: 533

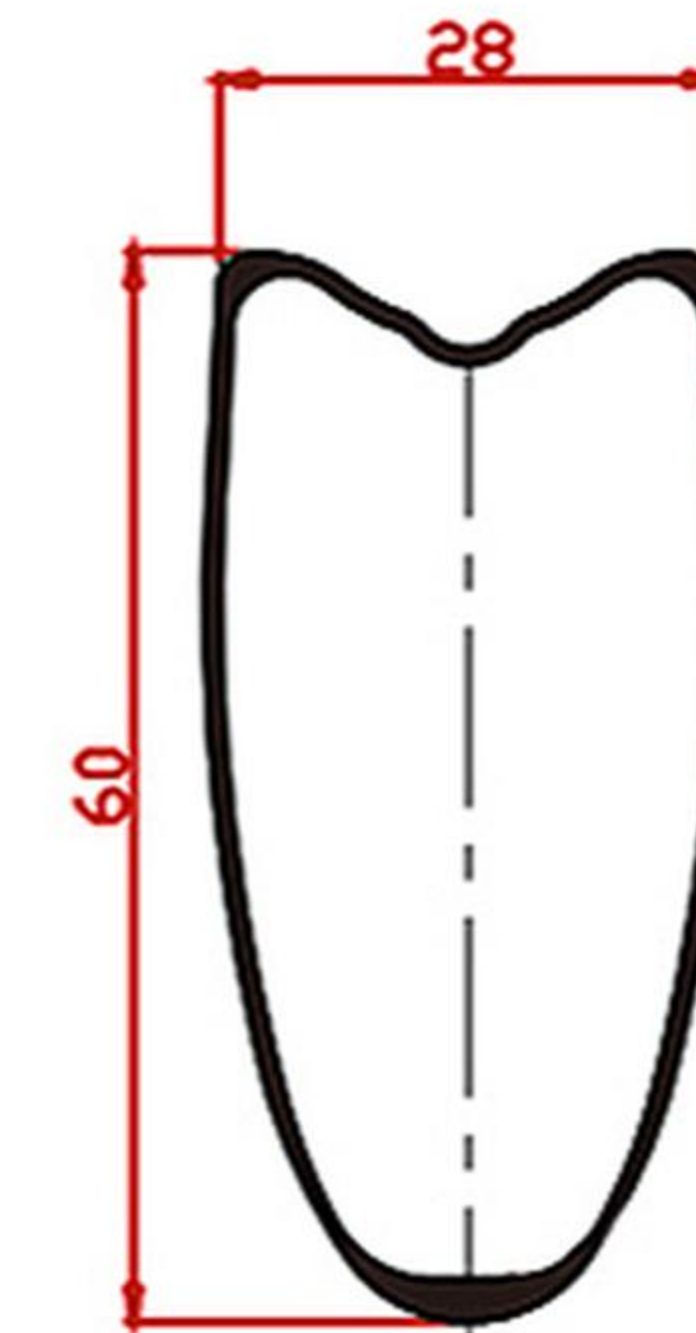

Model: R60T-28
Weight: T700: 465±15g
T800: 430±10g
ERD: 524

► 21mm Inner Width Rims T700/T800 Series

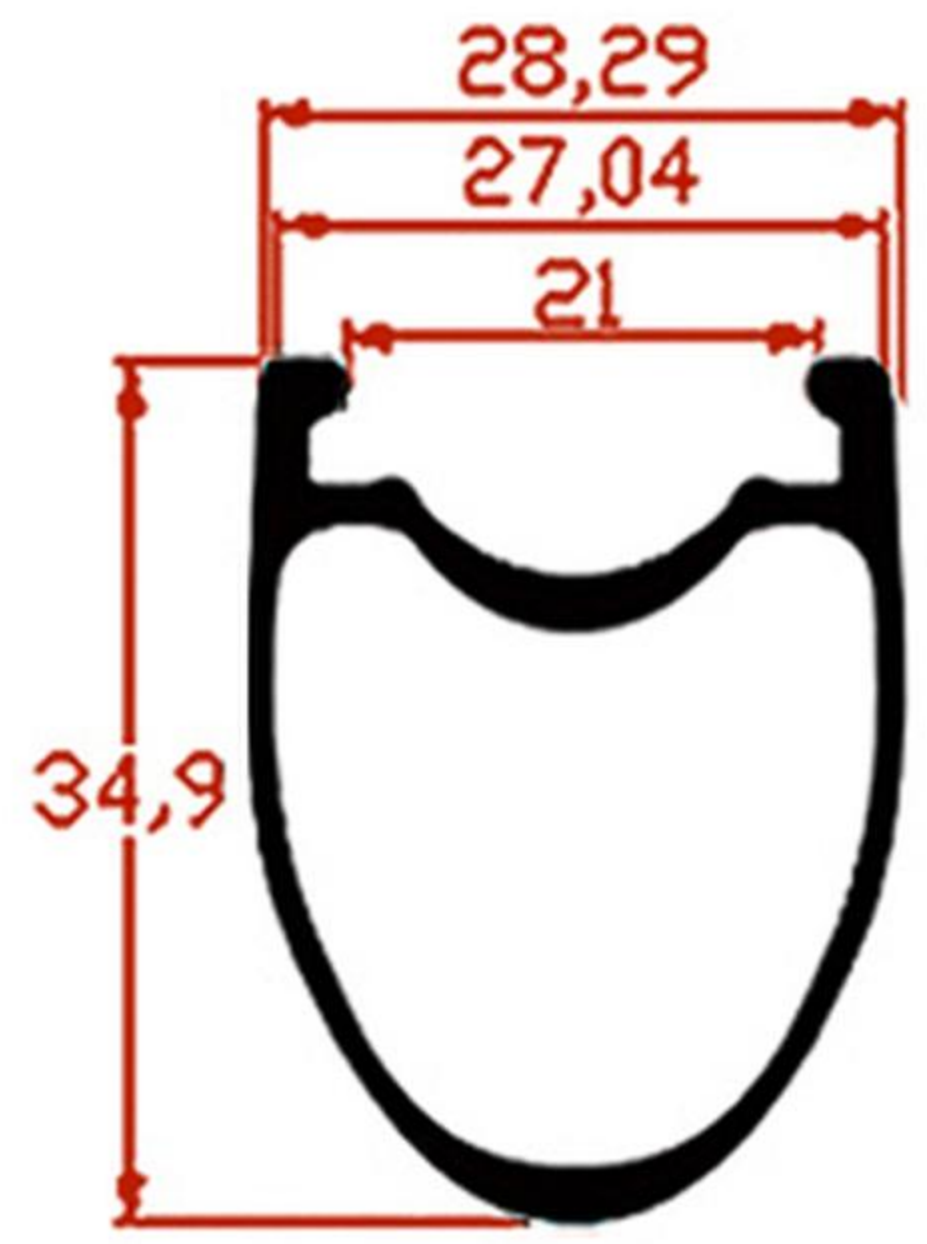

Model: R35TL-28-UL
Weight: 320±10g
ERD: 569

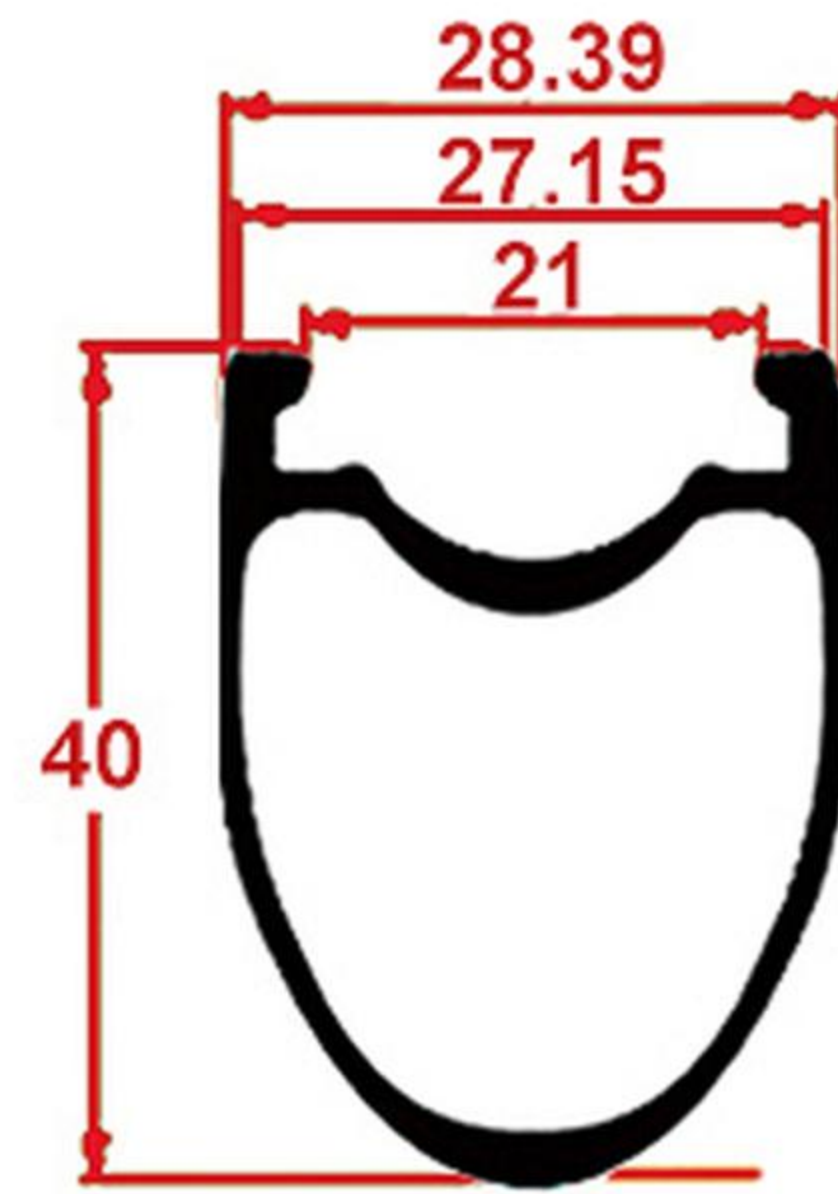

Model: R40TL-28-UL
Weight: 340±15g
ERD: 559

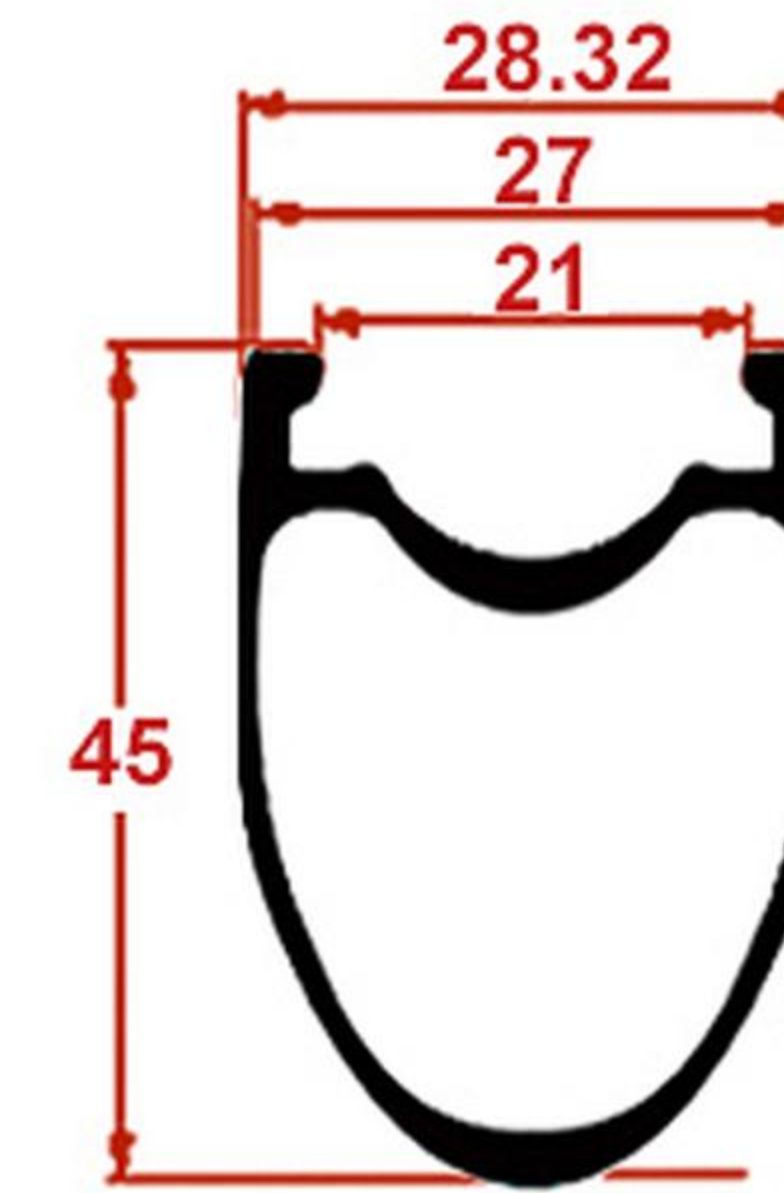

Model: R45TL-28-UL
Weight: 360±15g
ERD: 549

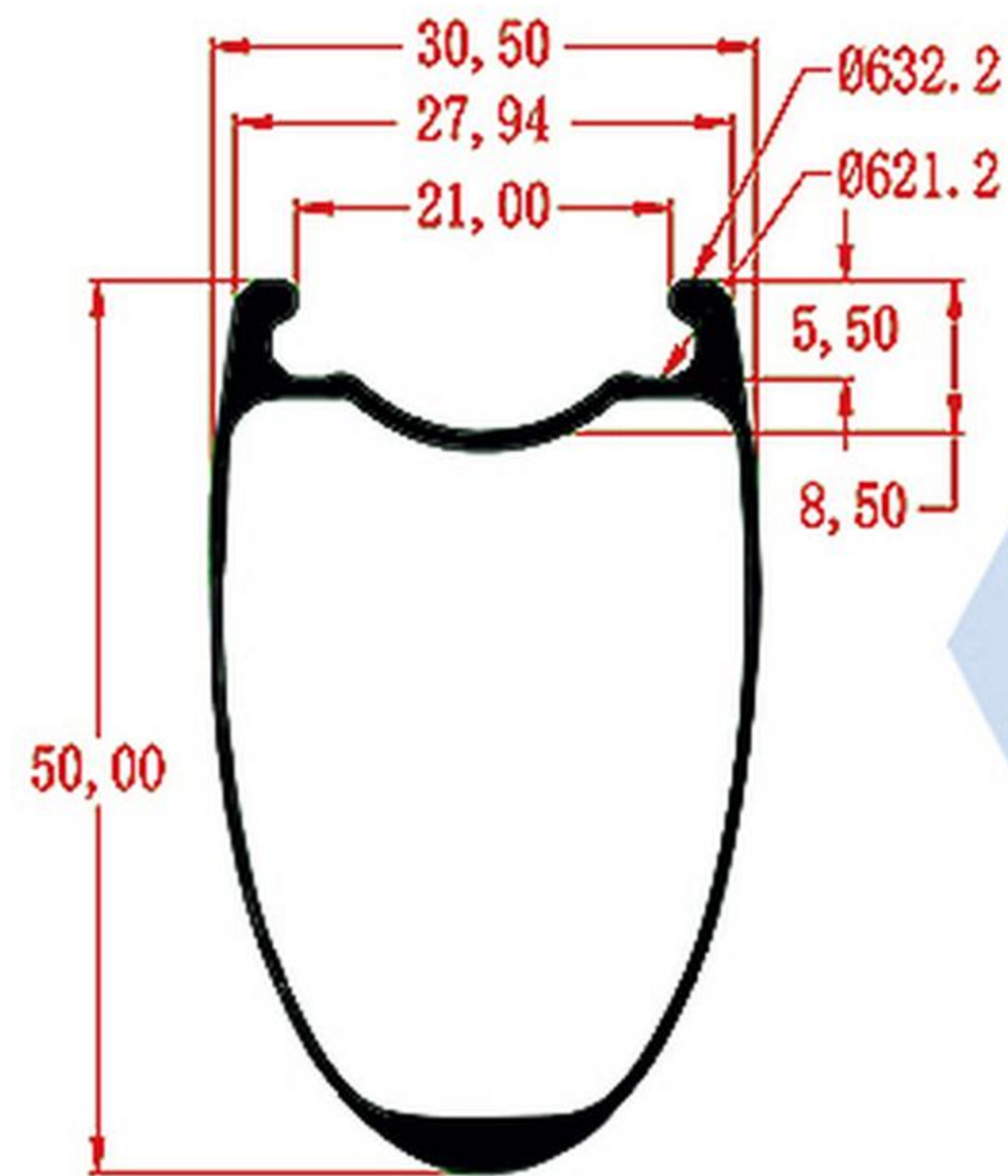

Model: R50TL-28-UL
Weight: 385±15g
ERD: 539

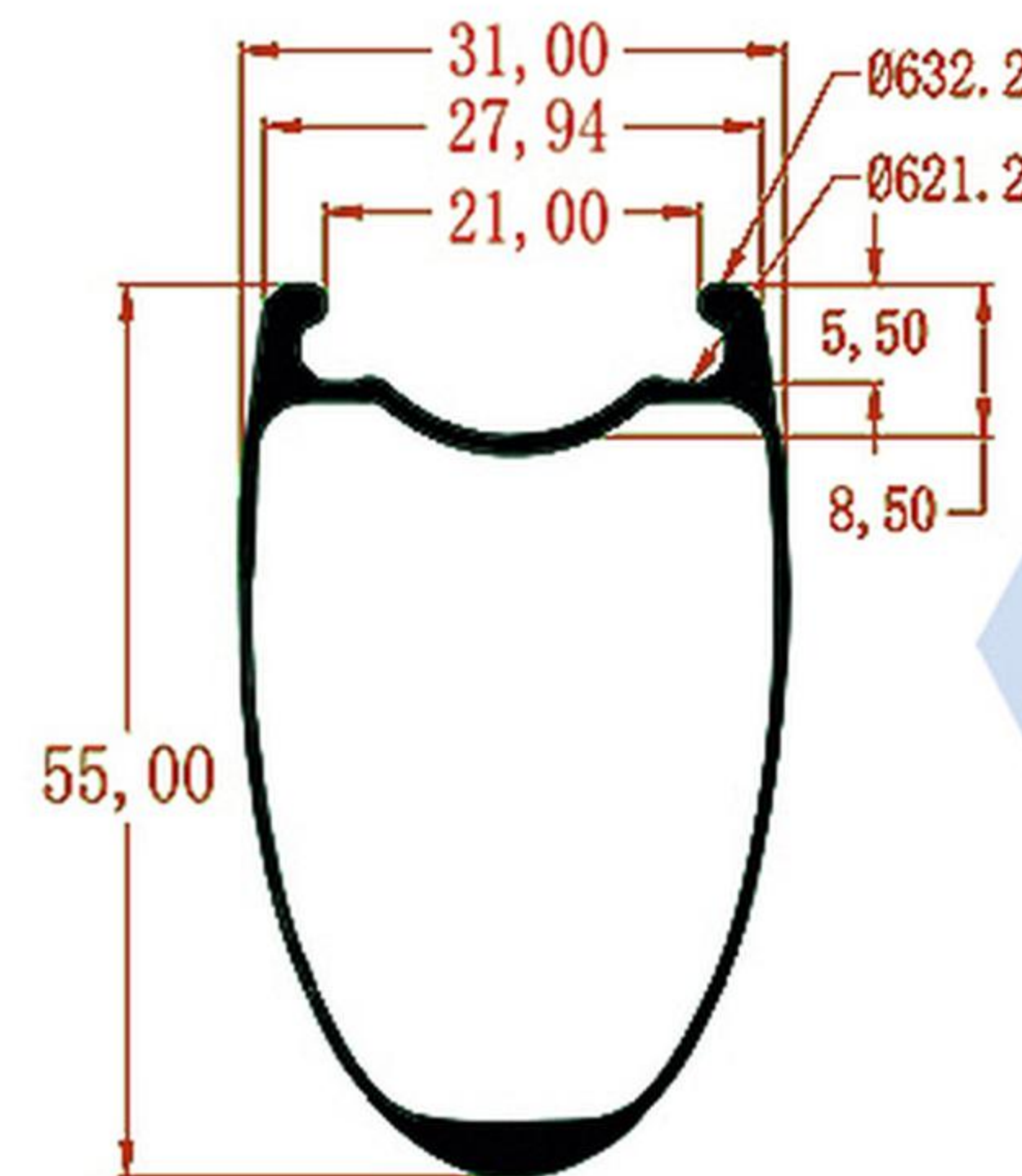

Model: R55TL-28-UL
Weight: 420±15g
ERD: 529

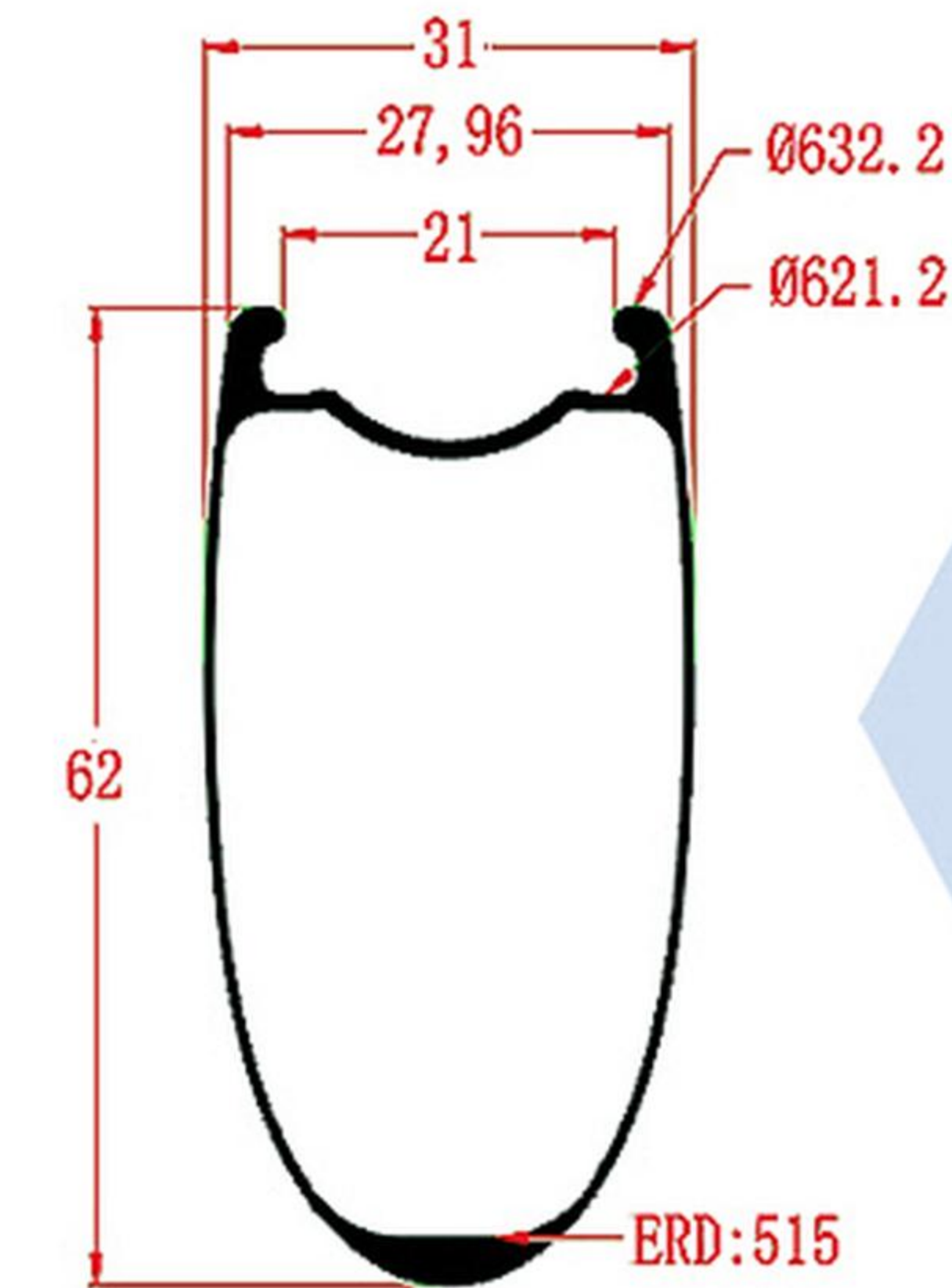

Model: R62TL-28-UL
Weight: 450±15g
ERD: 515

► 28mm Road Rims Tubeless Wave Shape

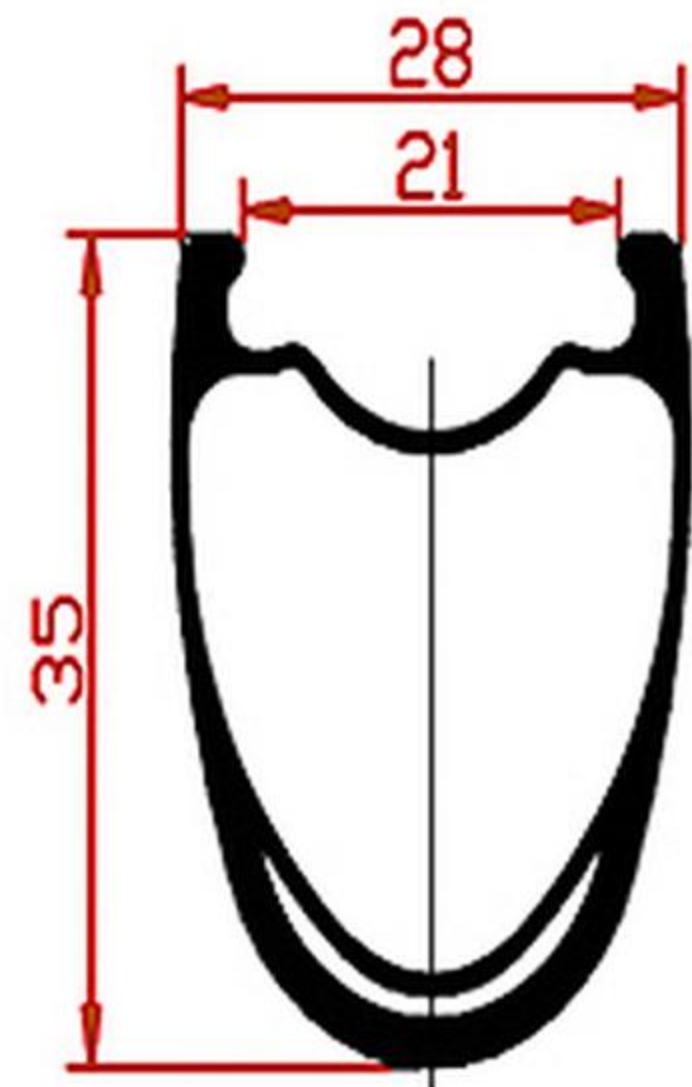

Model: W35TL-28
 Weight: T700: 420±15g
 T800: 380±15g
 ERD: 569

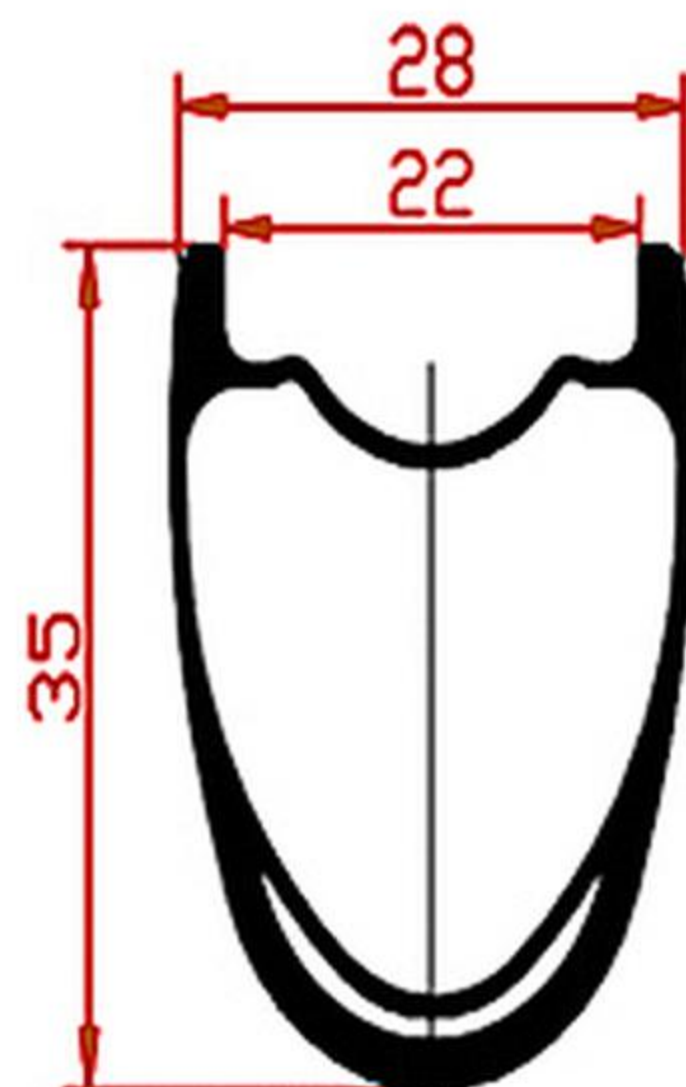

Model: W35HL-28
 Weight: T700: 400±15g
 T800: 360±15g
 ERD: 569

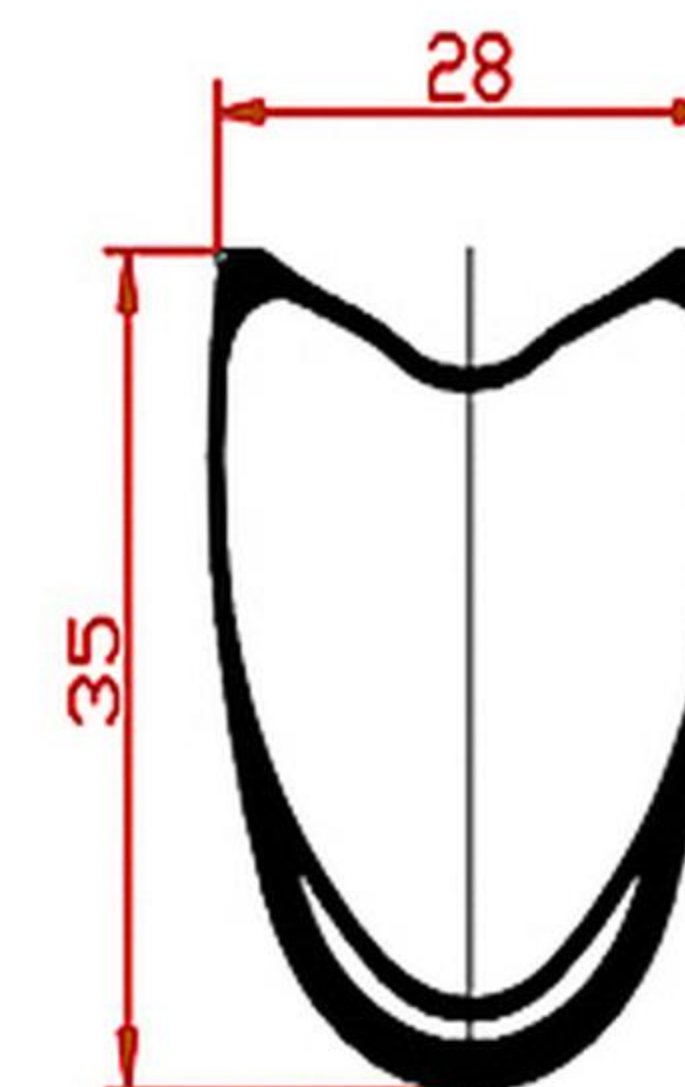

Model: W35T-28
 Weight: T700: 360±15g
 T800: 320±15g
 ERD: 569

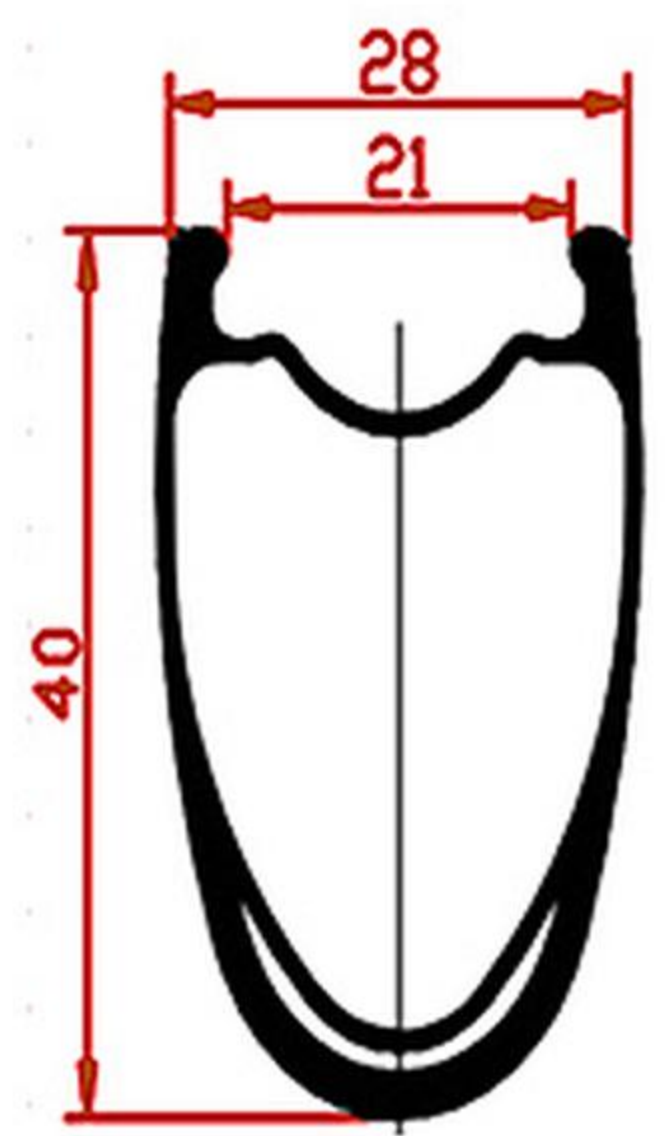

Model: W40TL-28
 Weight: T700: 440±15g
 T800: 400±15g
 ERD: 559

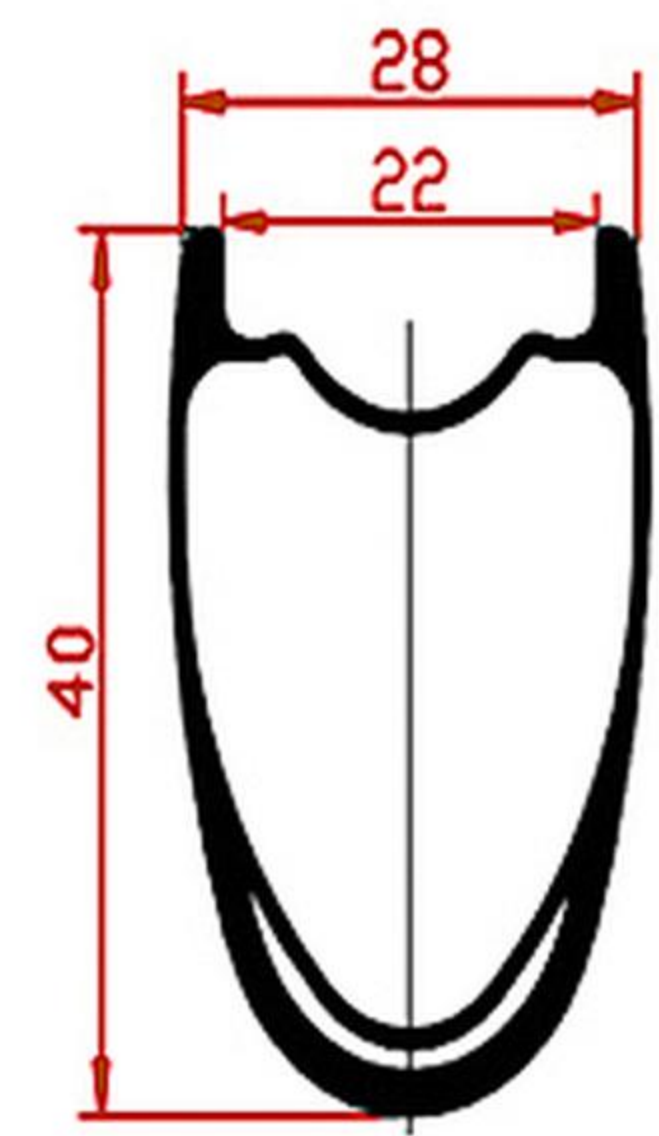

Model: W40HL-28
 Weight: T700: 420±15g
 T800: 380±15g
 ERD: 559

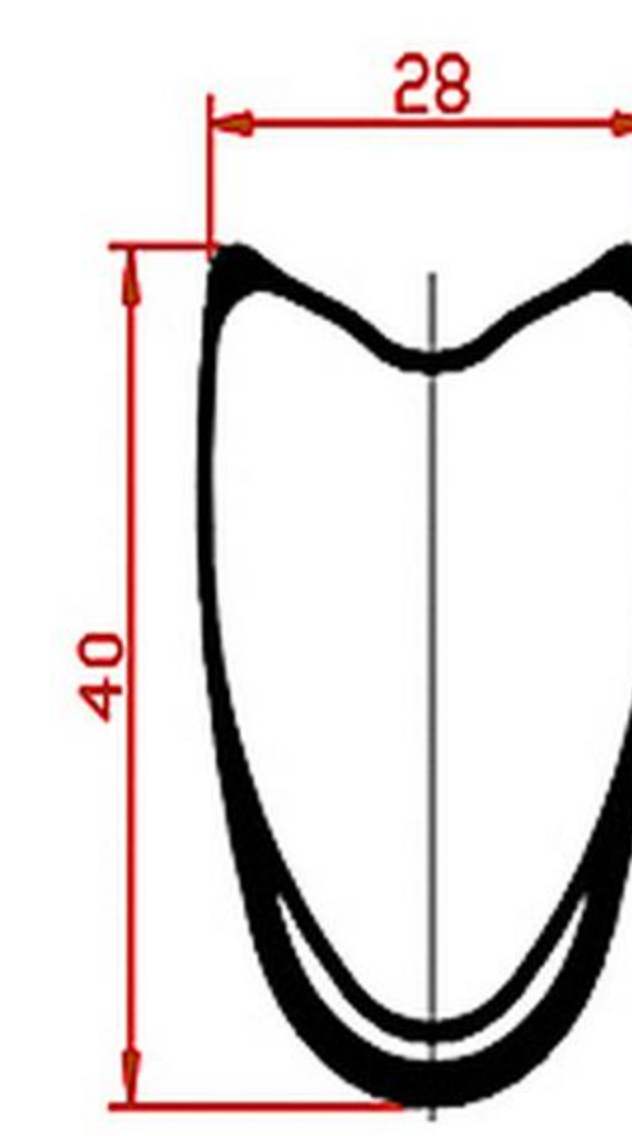

Model: W40T-28
 Weight: T700: 380±15g
 T800: 340±15g
 ERD: 559

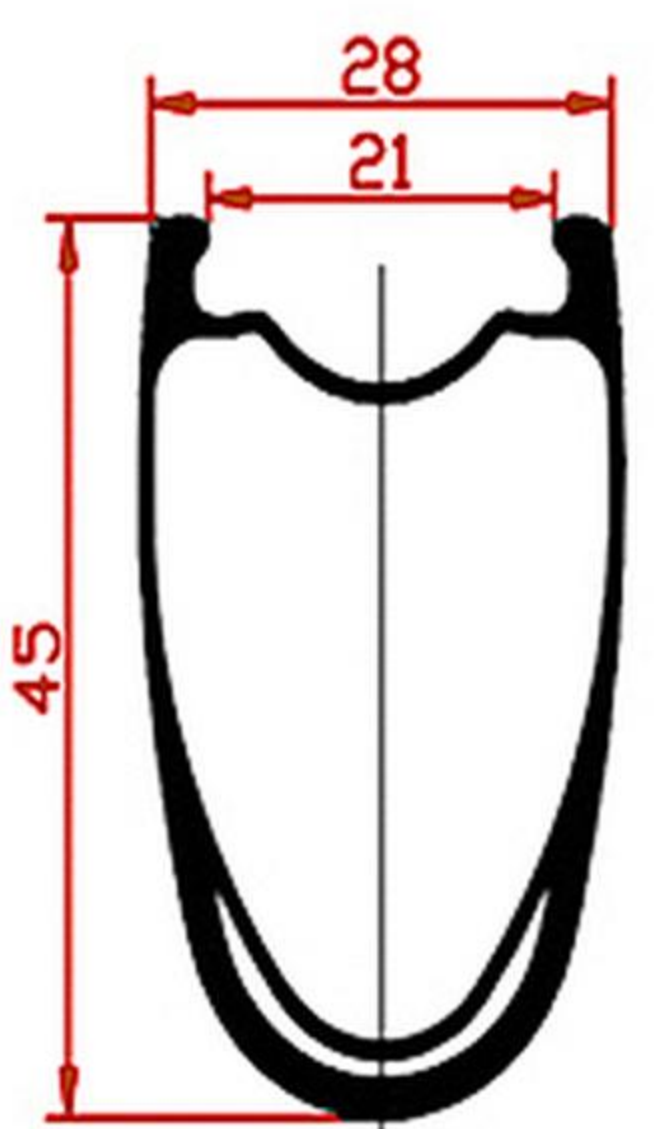

Model: W45TL-28
 Weight: T700: 460±15g
 T800: 420±15g
 ERD: 549

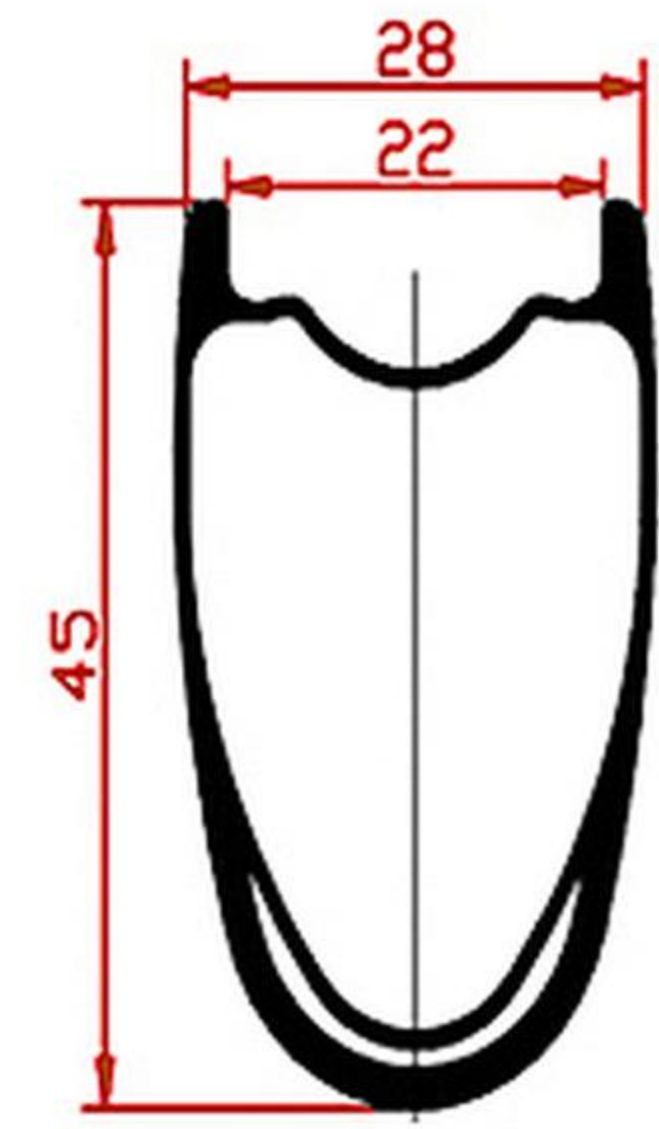

Model: W45HL-28
 Weight: T700: 440±15g
 T800: 400±15g
 ERD: 549

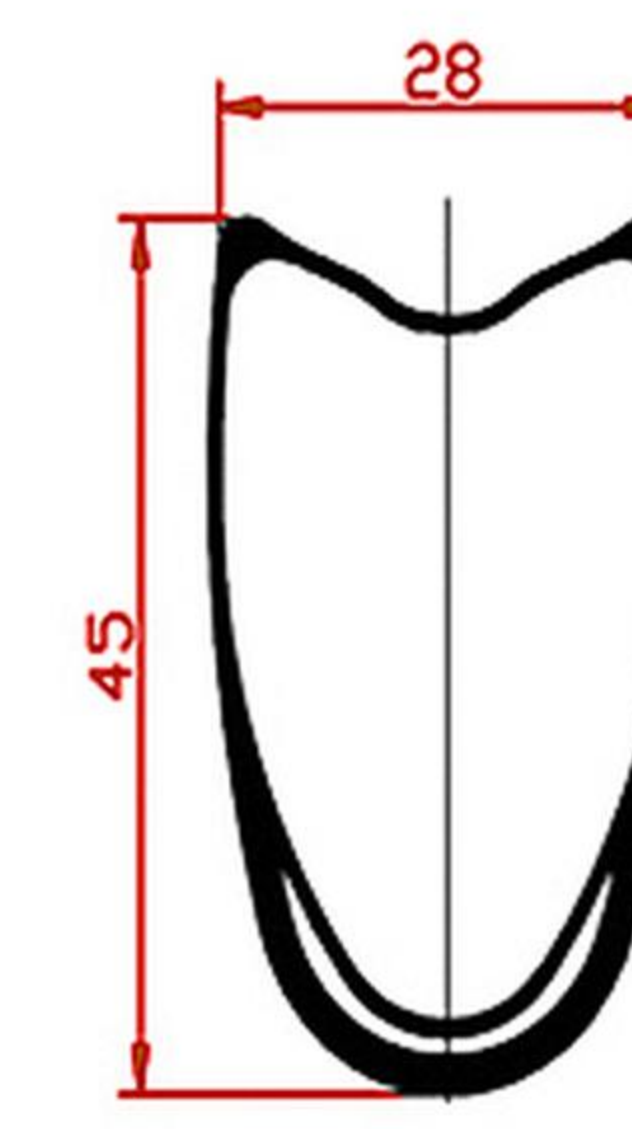

Model: W45T-28
 Weight: T700: 400±15g
 T800: 360±15g
 ERD: 549

► 28mm Road Rims Tubeless Wave Shape

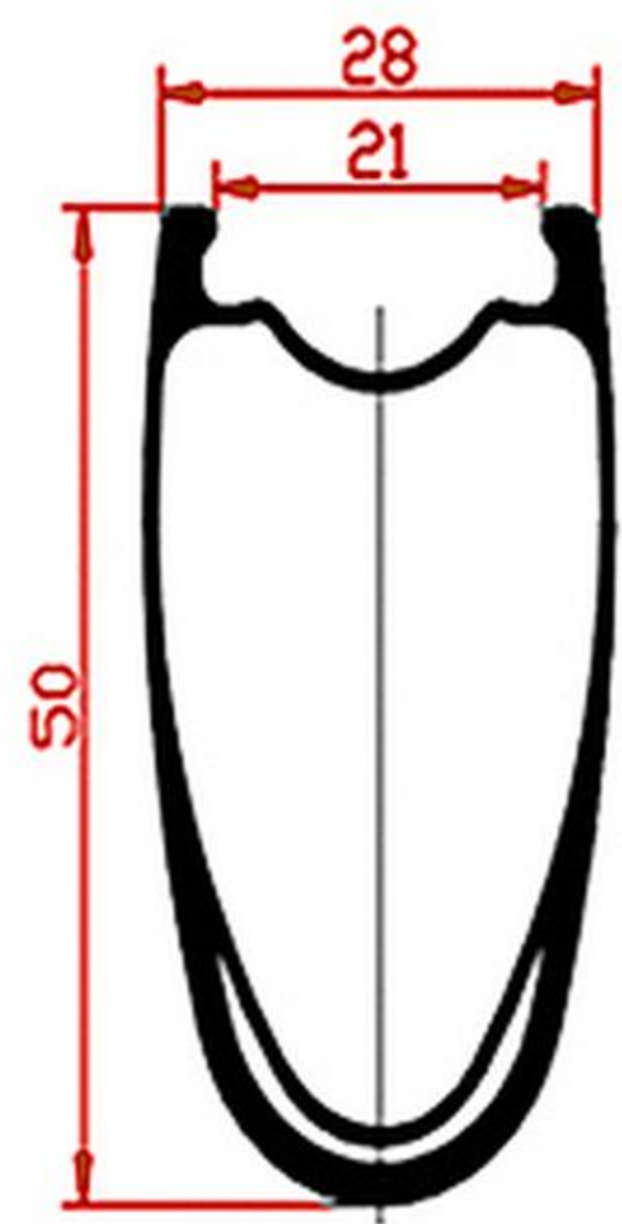

Model: W50TL-28
 Weight: T700: 480±15g
 T800: 440±15g
 ERD: 539

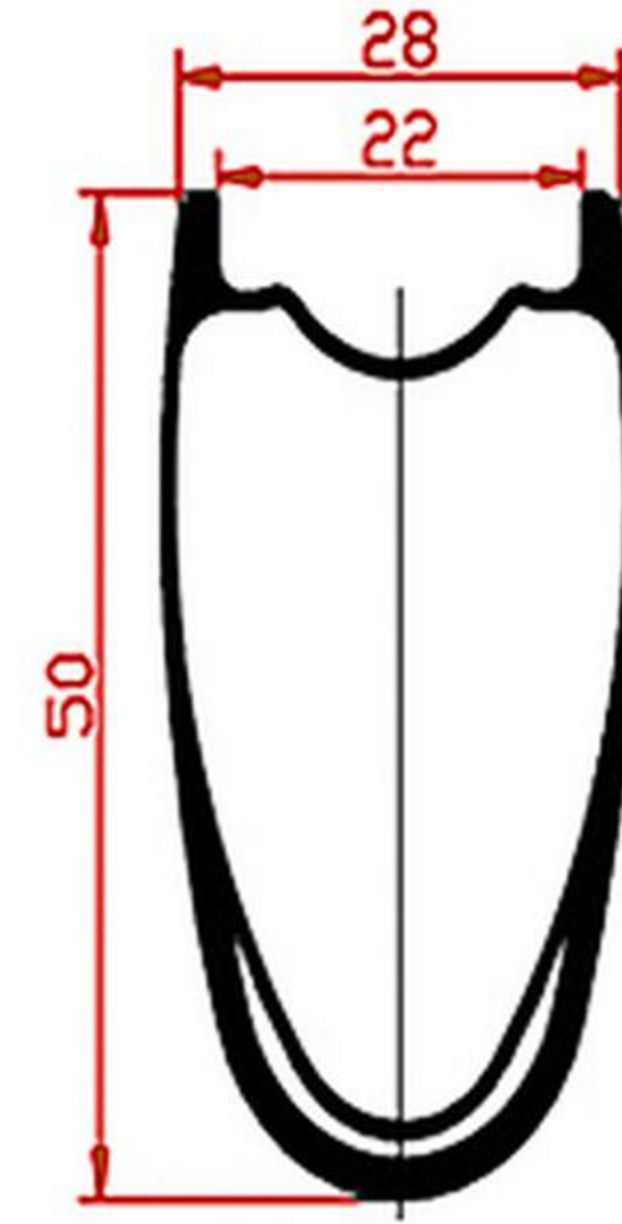

Model: W50HL-28
 Weight: T700: 460±15g
 T800: 420±15g
 ERD: 539

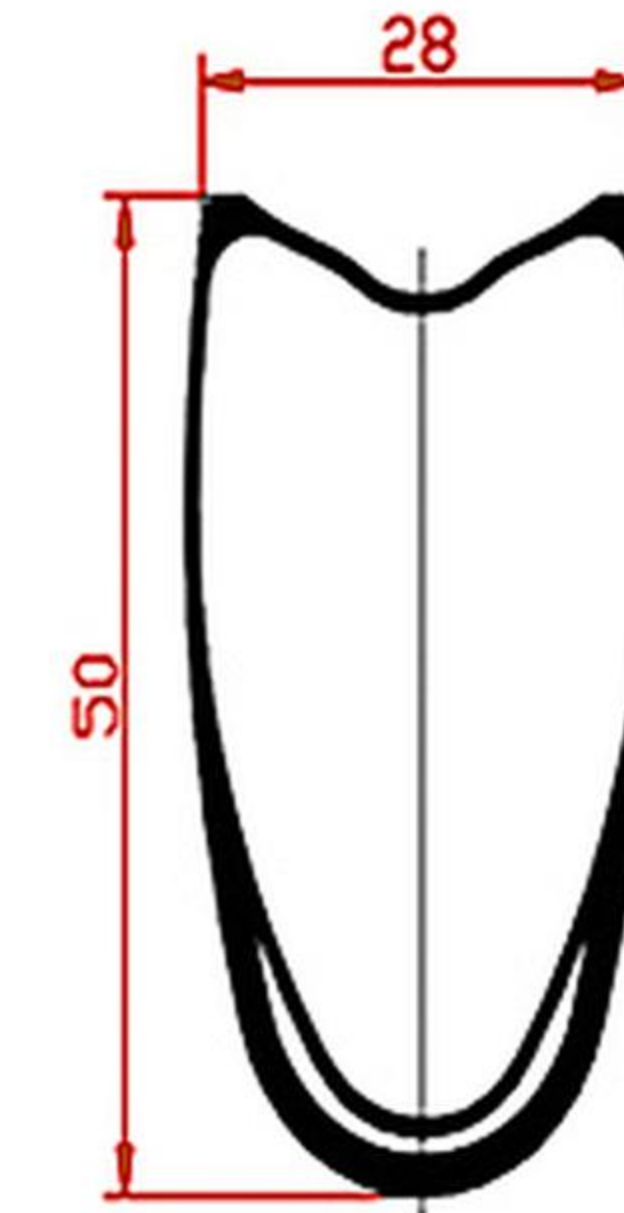

Model: W50T-28
 Weight: T700: 400±15g
 T800: 360±15g
 ERD: 539

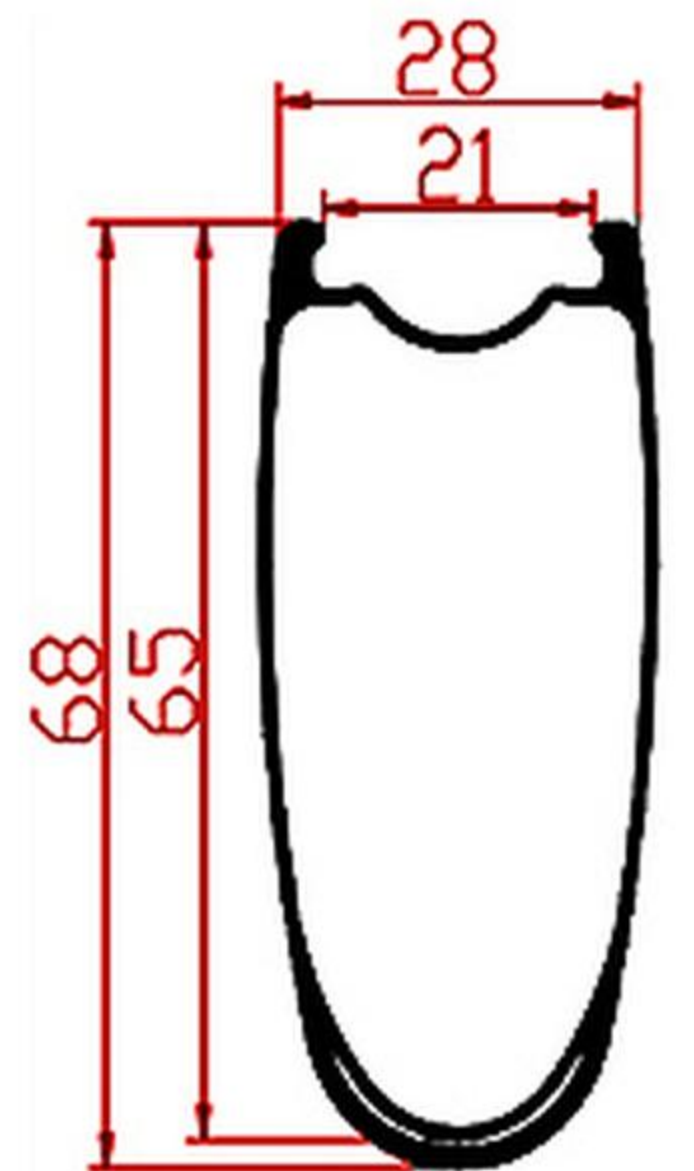

Model: W68TL-28
 Weight: T700: 560±15g
 T800: 520±15g
 ERD: 503

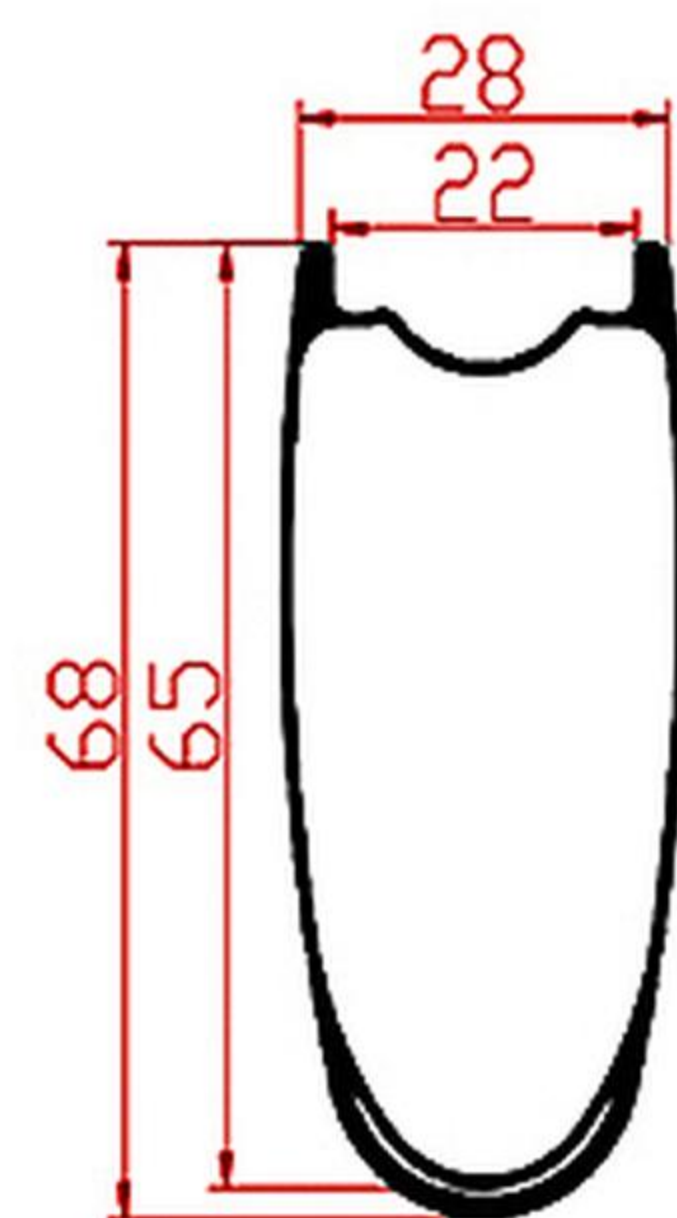

Model: W68HL-28
 Weight: T700: 560±15g
 T800: 520±15g
 ERD: 503

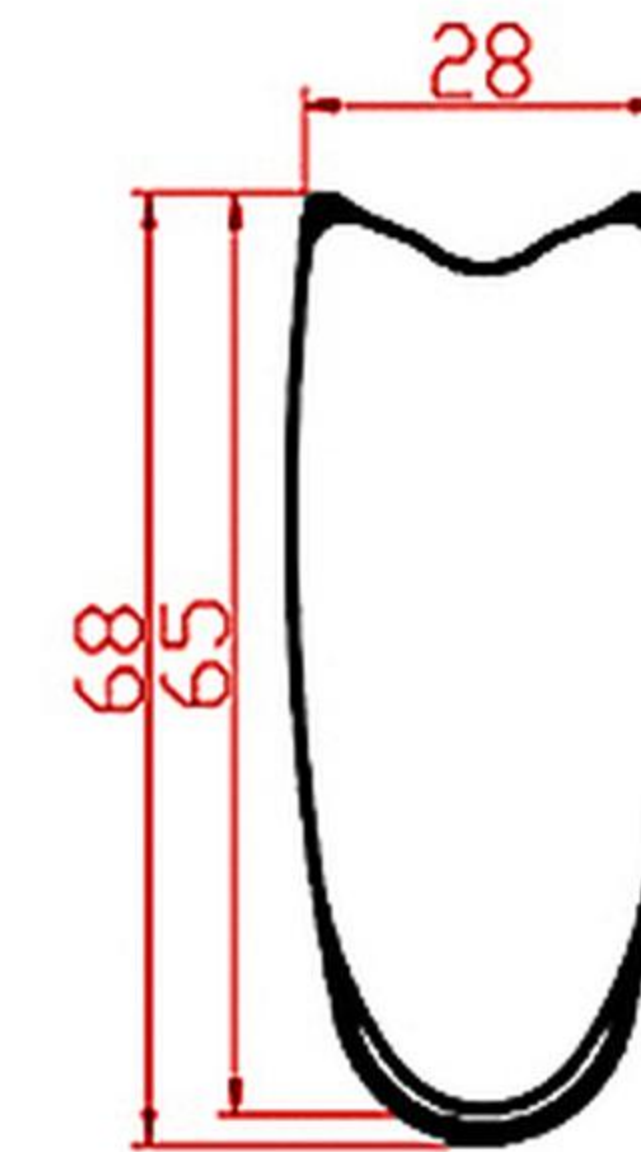

Model: W68T-28
 Weight: T700: 500±15g
 T800: 460±15g
 ERD: 503

► 28mm Road Rims Tubeless Wave Shape Asymmetric

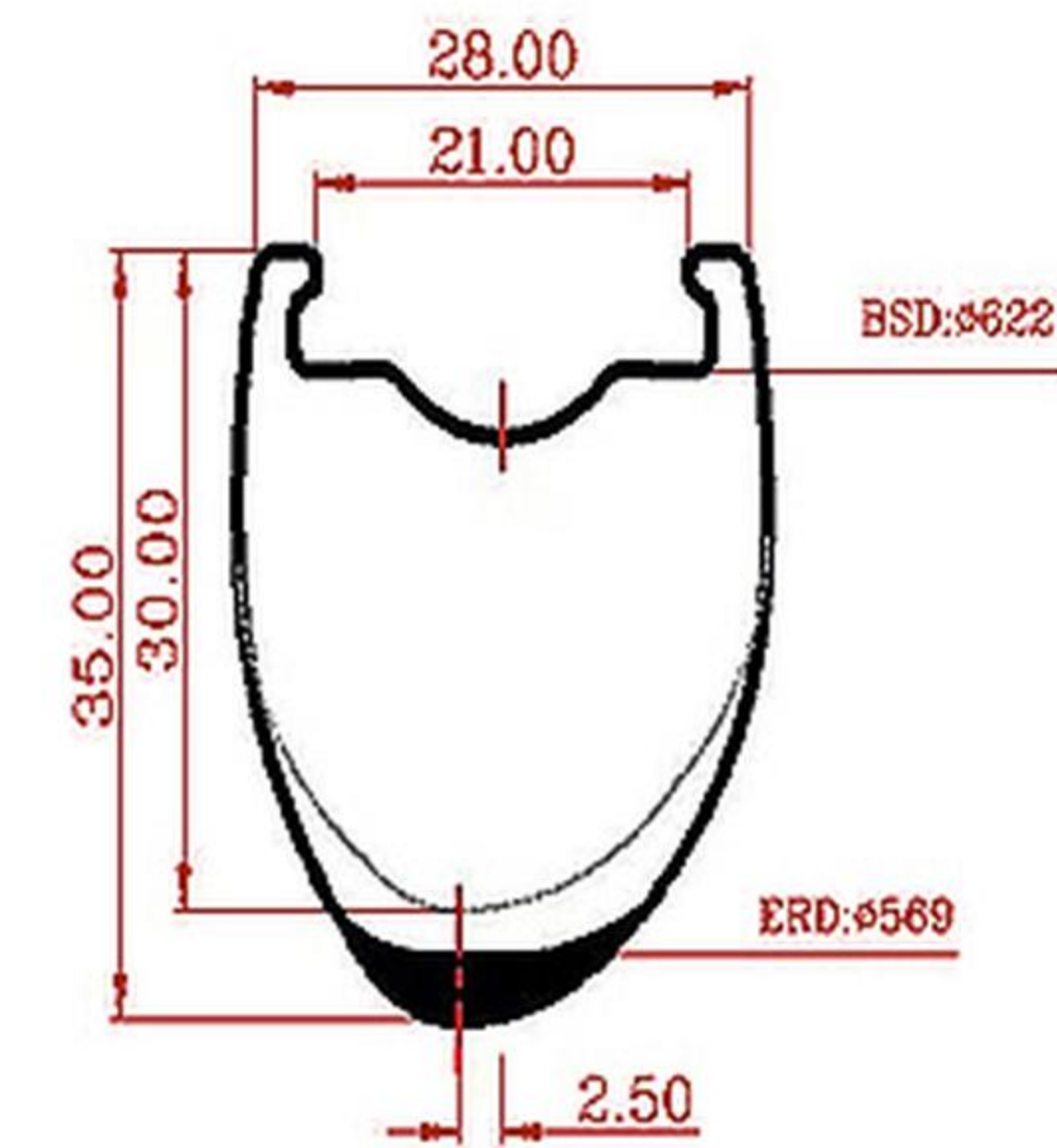

NEW

Model: W35TL-28-ASY
 Weight: T700: 400±15g
 T800: 360±10g
 ERD: 569

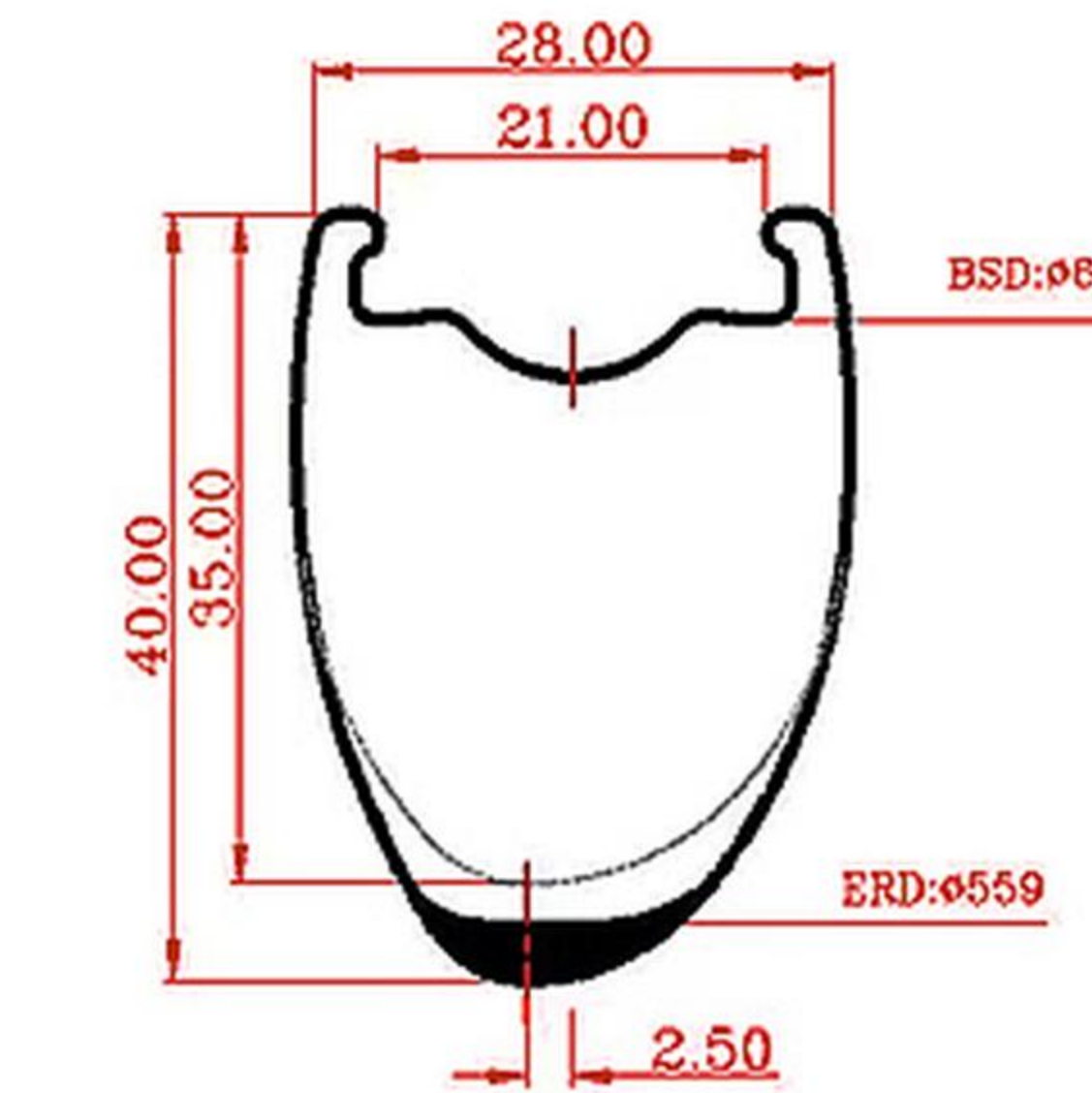
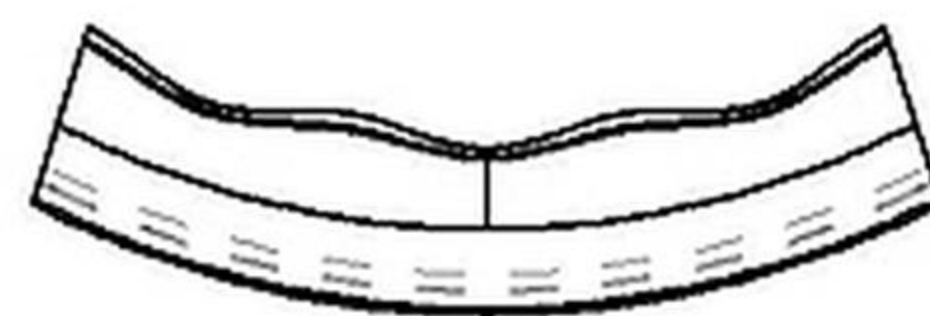

NEW

Model: W40TL-28-ASY
 Weight: T700: 420±15g
 T800: 375±10g
 ERD: 559

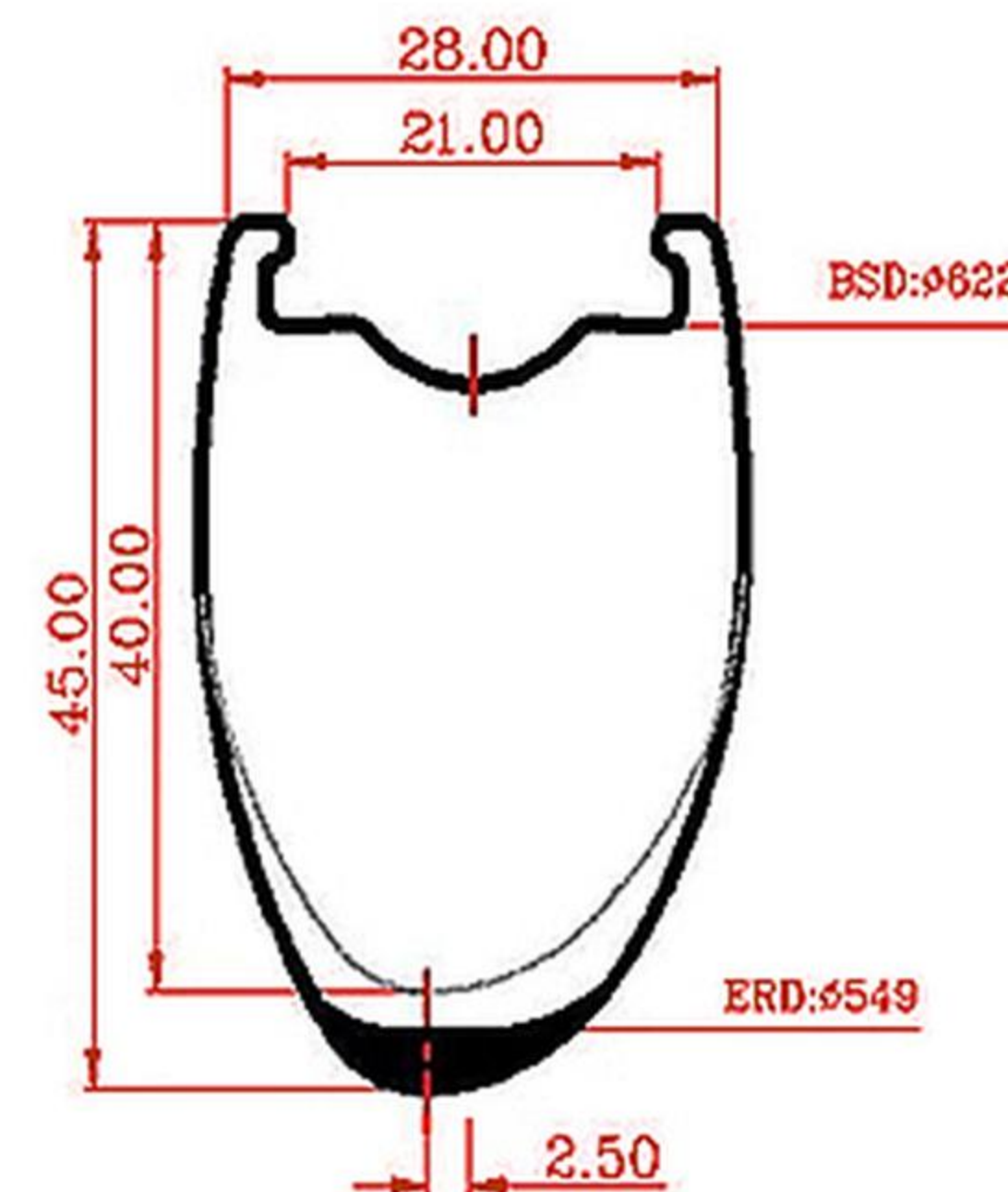
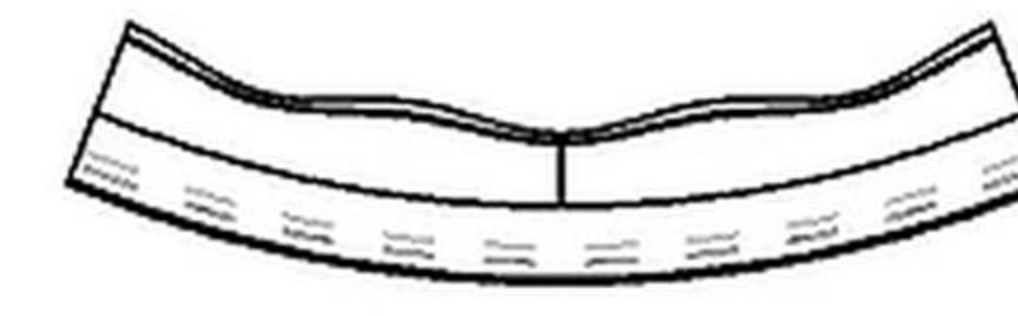

NEW

Model: W45TL-28-ASY
 Weight: T700: 435±15g
 T800: 390±10g
 ERD: 549

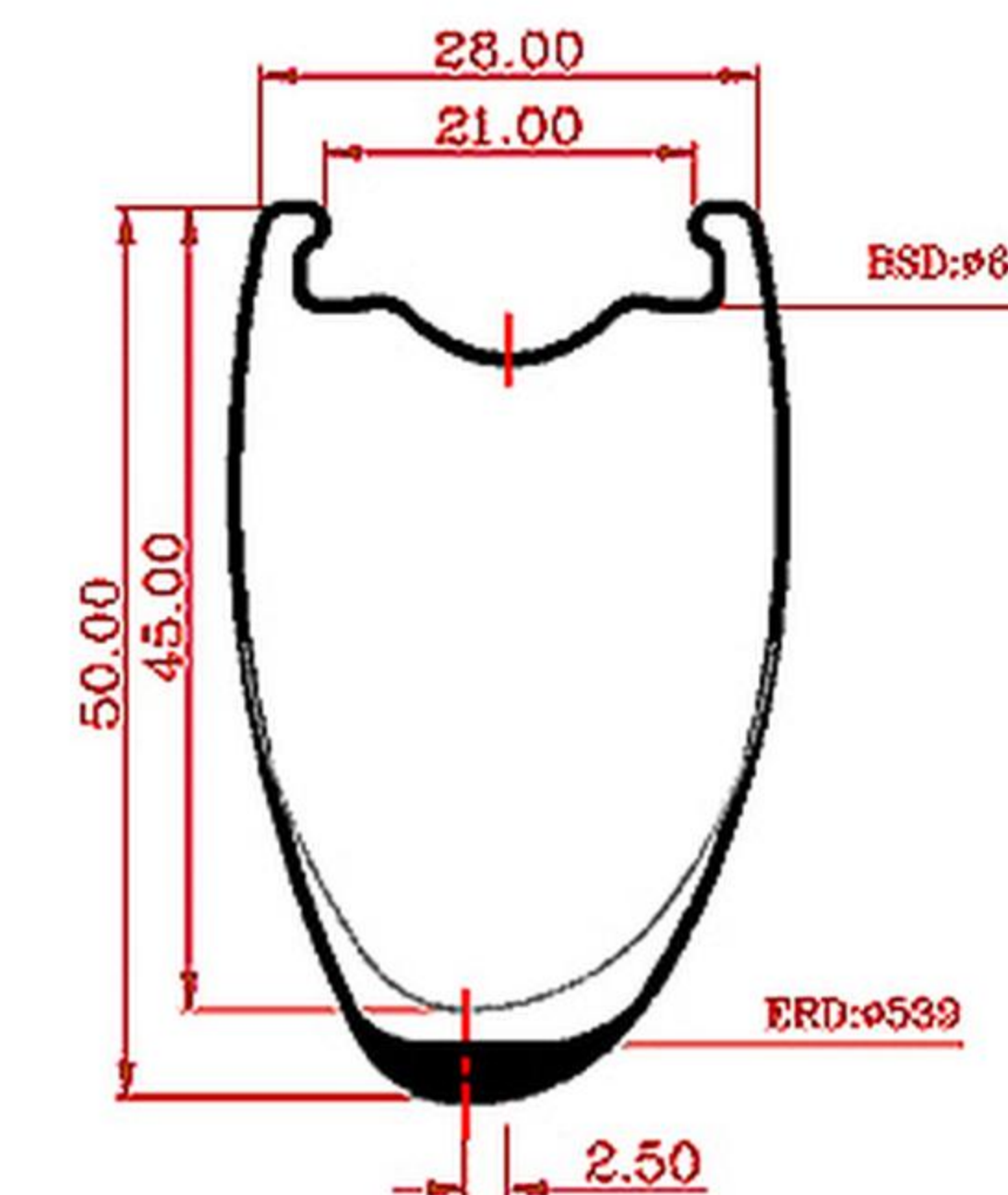
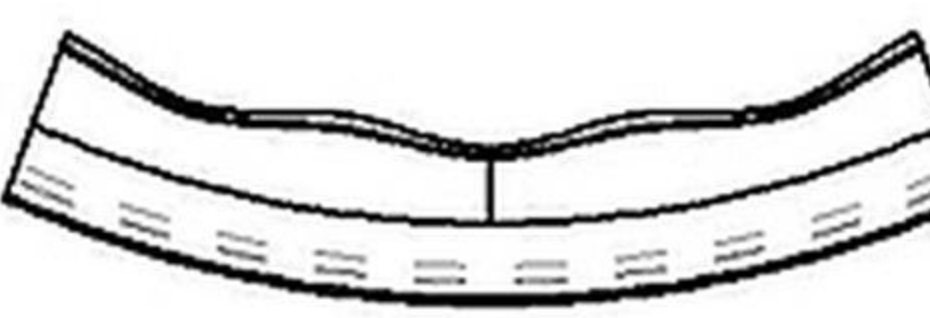

NEW

Model: W50TL-28-ASY
 Weight: T700: 450±15g
 T800: 405±10g
 ERD: 539

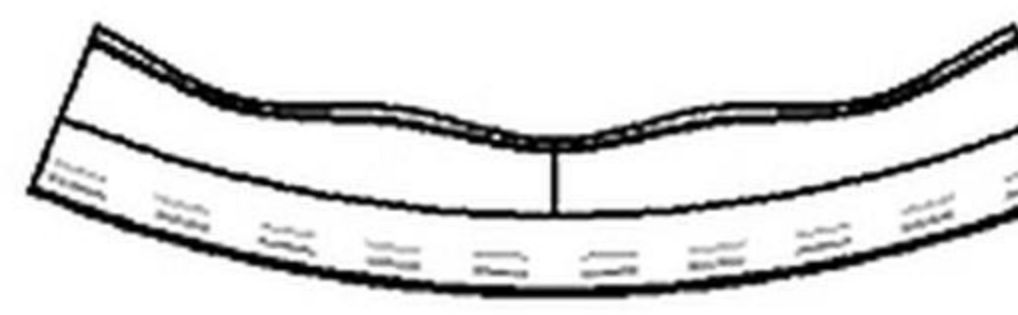

► 25mm Road Asymmetric Rims U-Shape

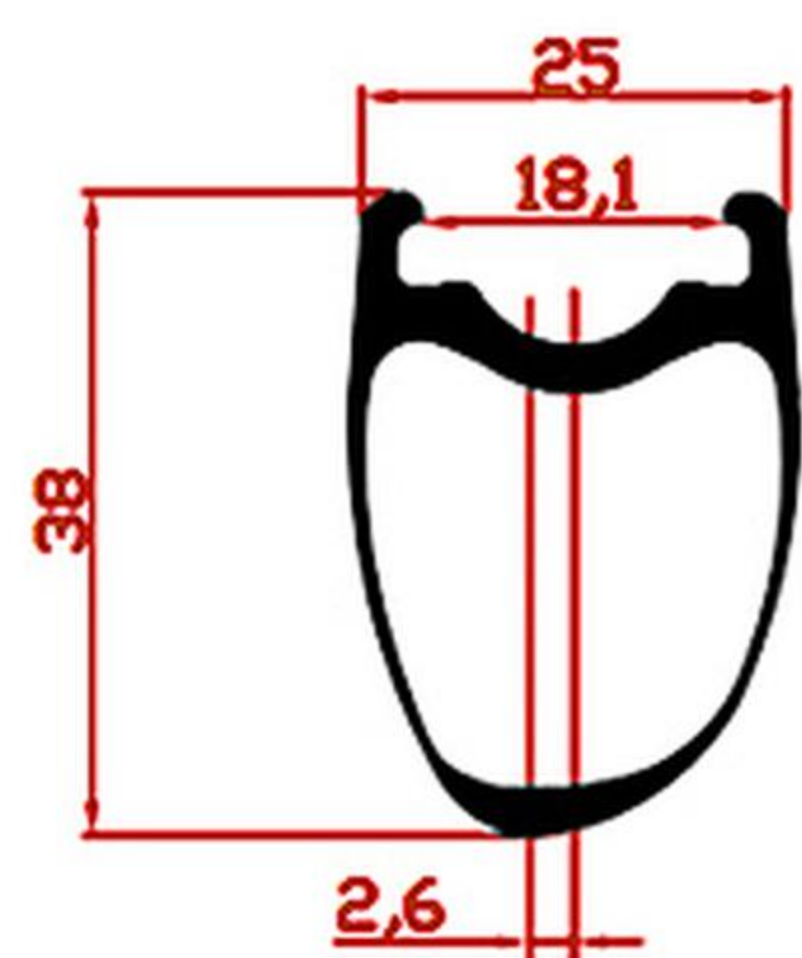

Model: R38TL-25-ASY
Weight: T700: 455±15g
T800: 390±15g
ERD: 569

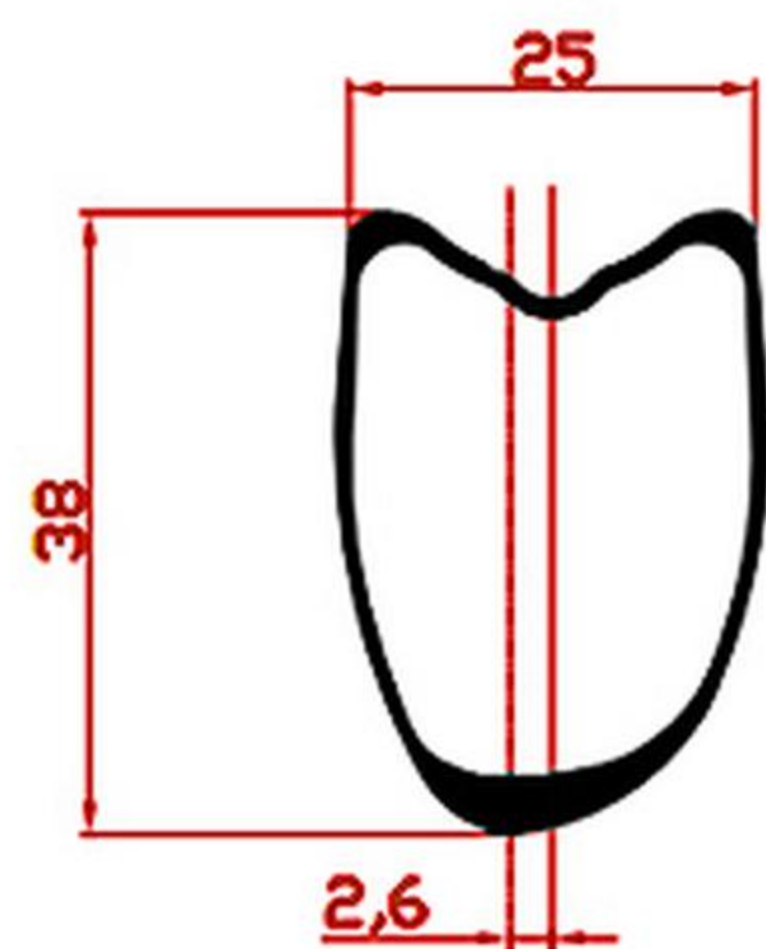

Model: R38T-25-ASY
Weight: T700: 355±15g
T800: 305±15g
ERD: 569

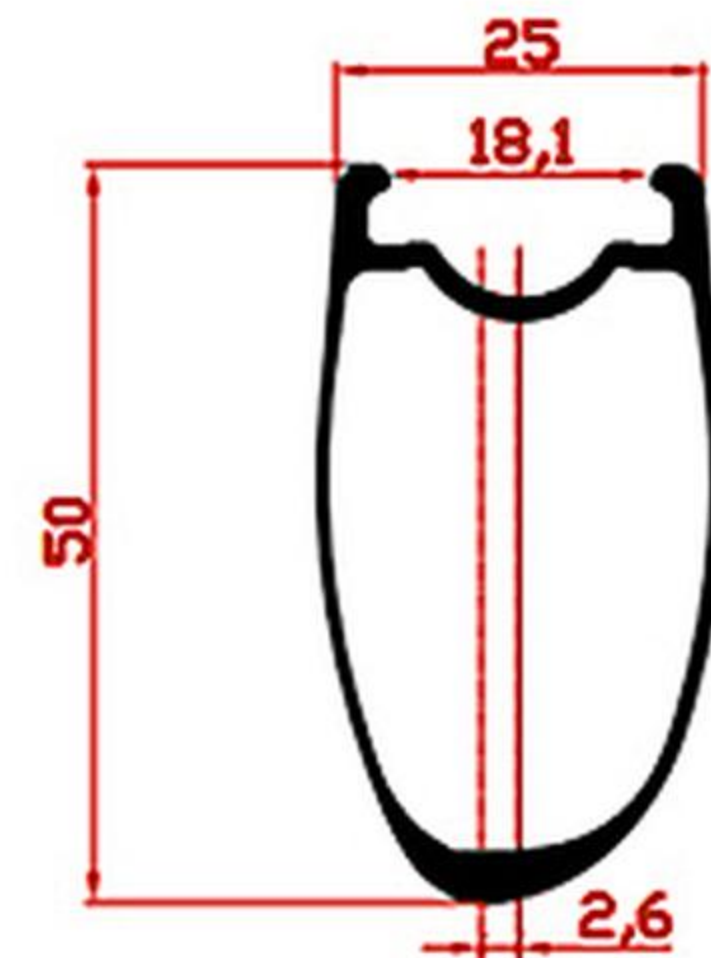

Model: R50TL-25-ASY
Weight: T700: 490±15g
T800: 430±15g
ERD: 545

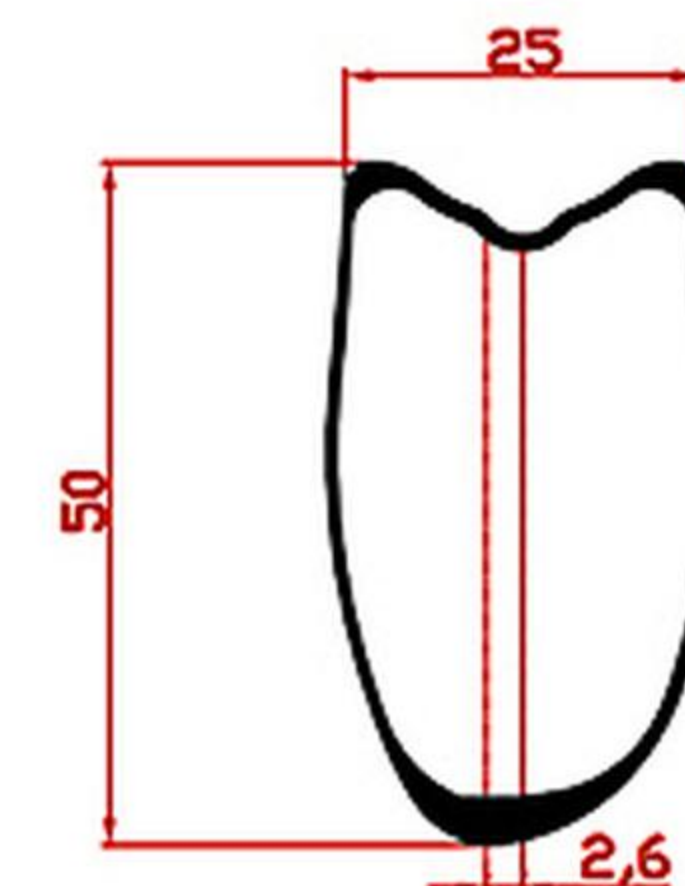

Model: R50T-25-ASY
Weight: T700: 390±15g
T800: 350±15g
ERD: 545

► 28mm Road Asymmetric Rims U-Shape

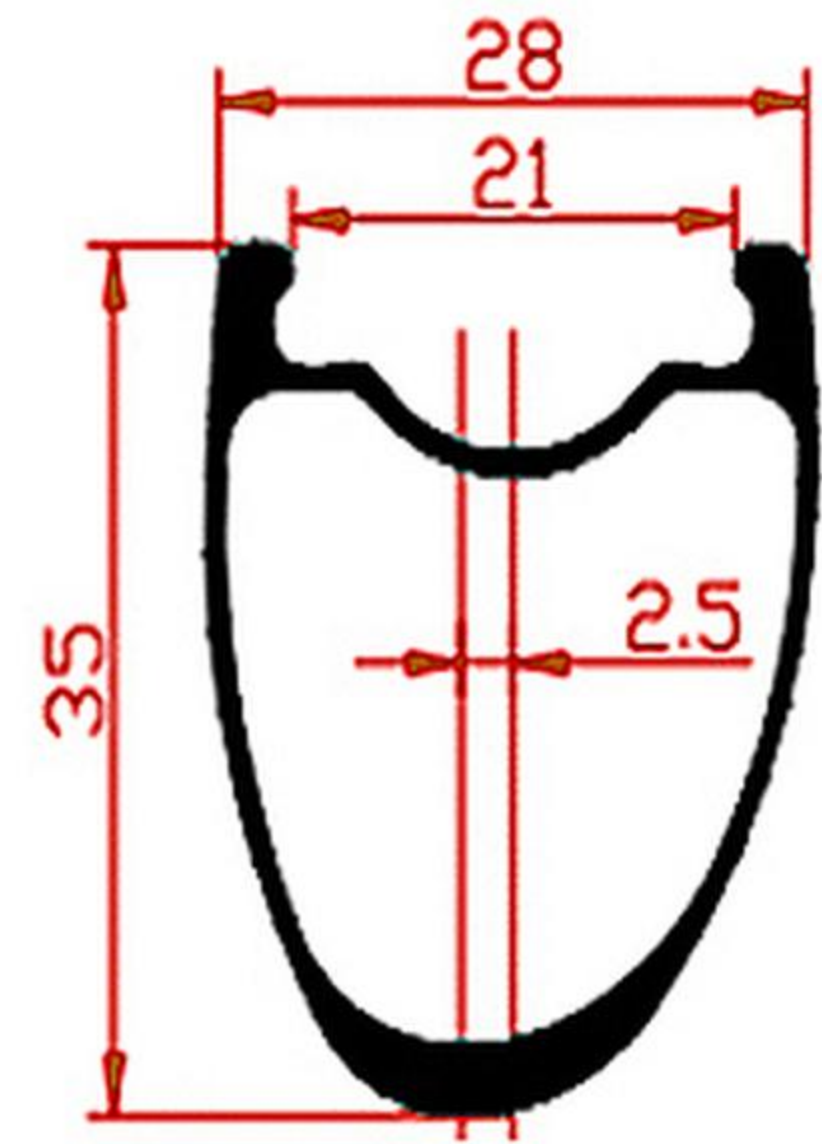

Model: R35TL-28-ASY
Weight: T700: 420±15g
T800: 380±15g
ERD: 569

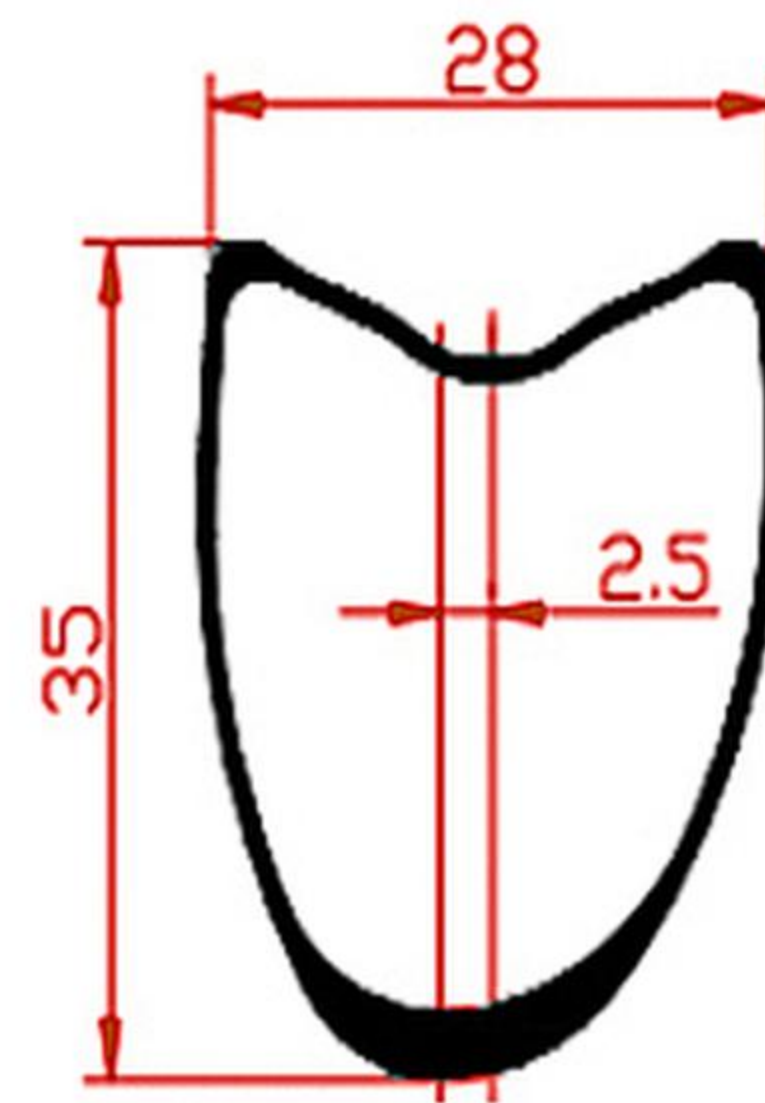

Model: R35T-28-ASY
Weight: T700: 360±15g
T800: 320±15g
ERD: 569

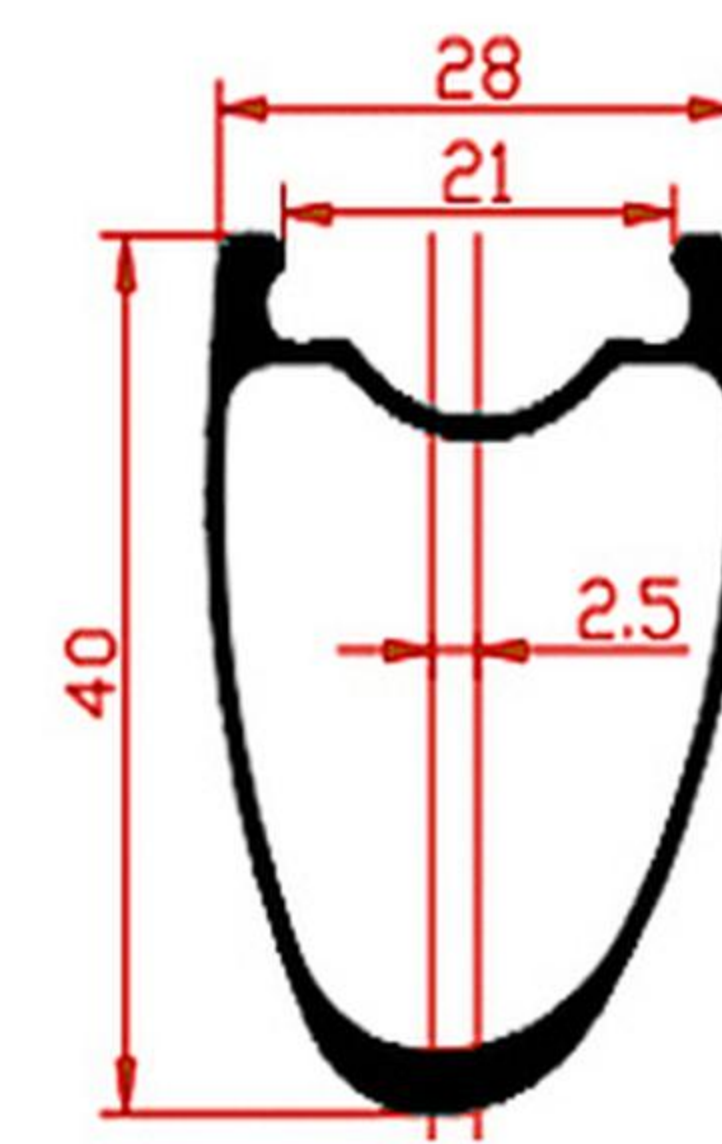

Model: R40TL-28-ASY
Weight: T700: 440±15g
T800: 400±15g
ERD: 559

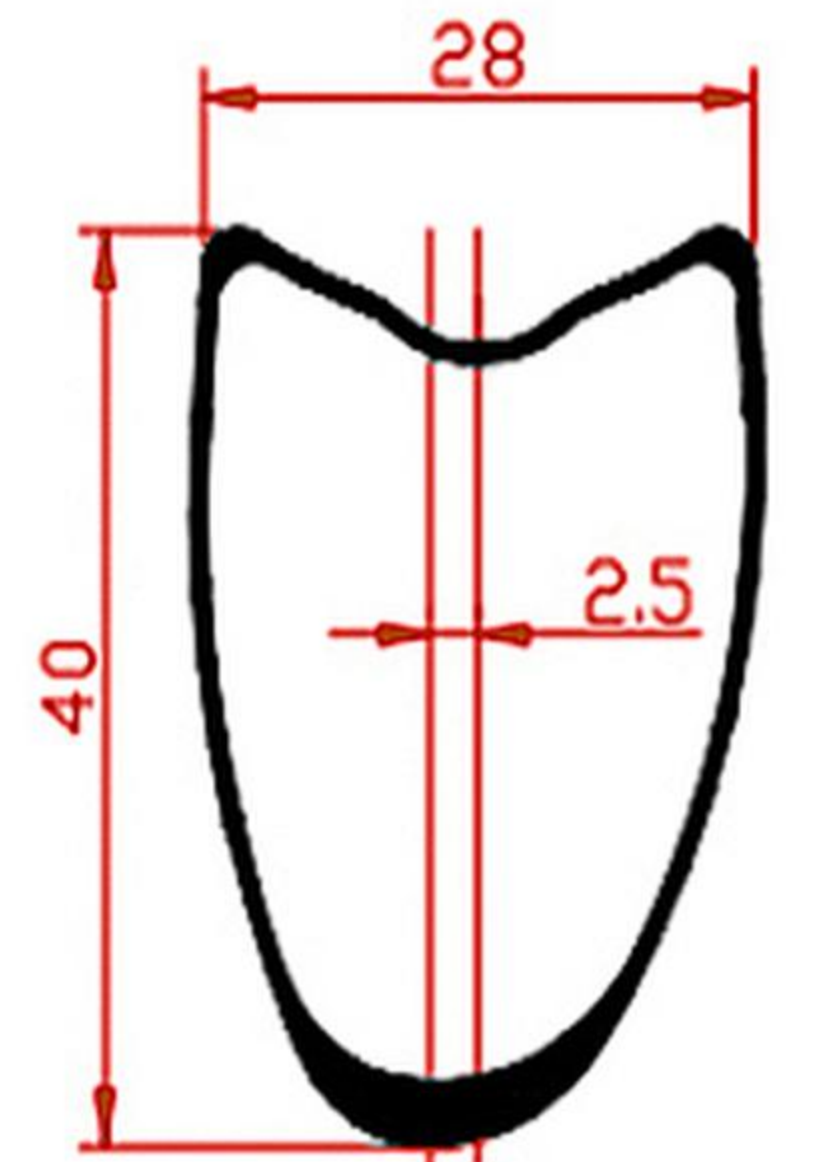

Model: R40T-28-ASY
Weight: T700: 380±15g
T800: 340±15g
ERD: 559

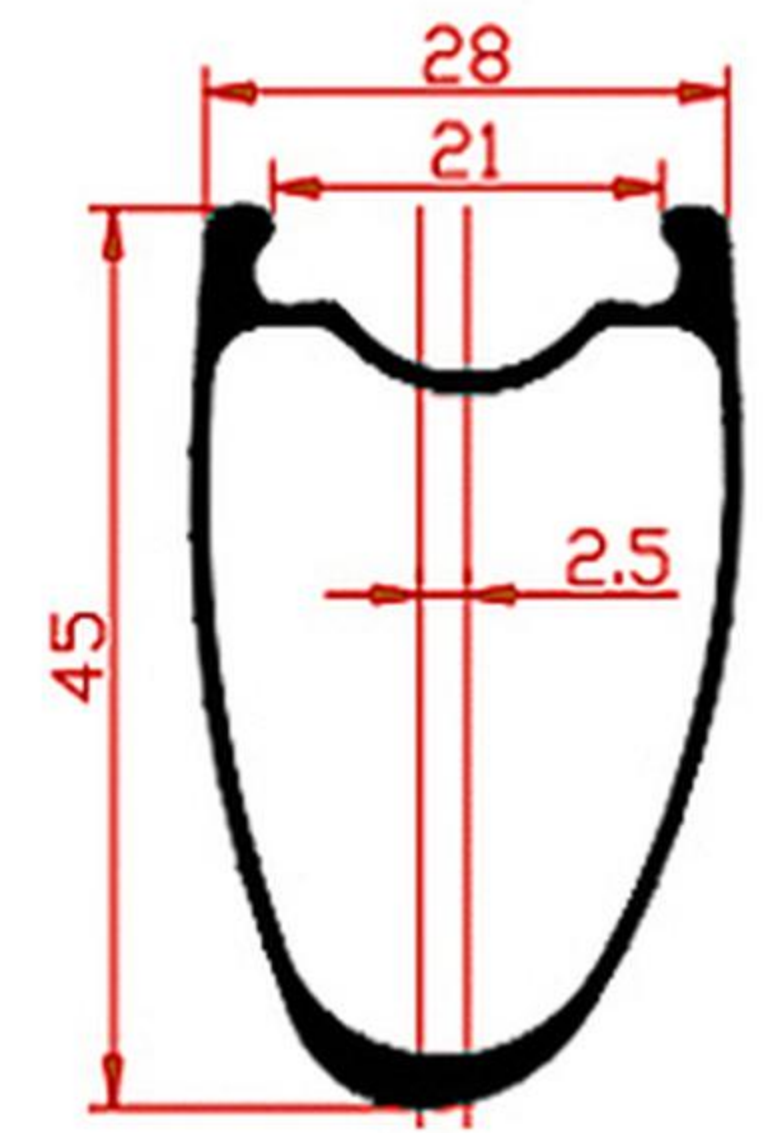

Model: R45TL-28-ASY
Weight: T700: 460±15g
T800: 420±15g
ERD: 549

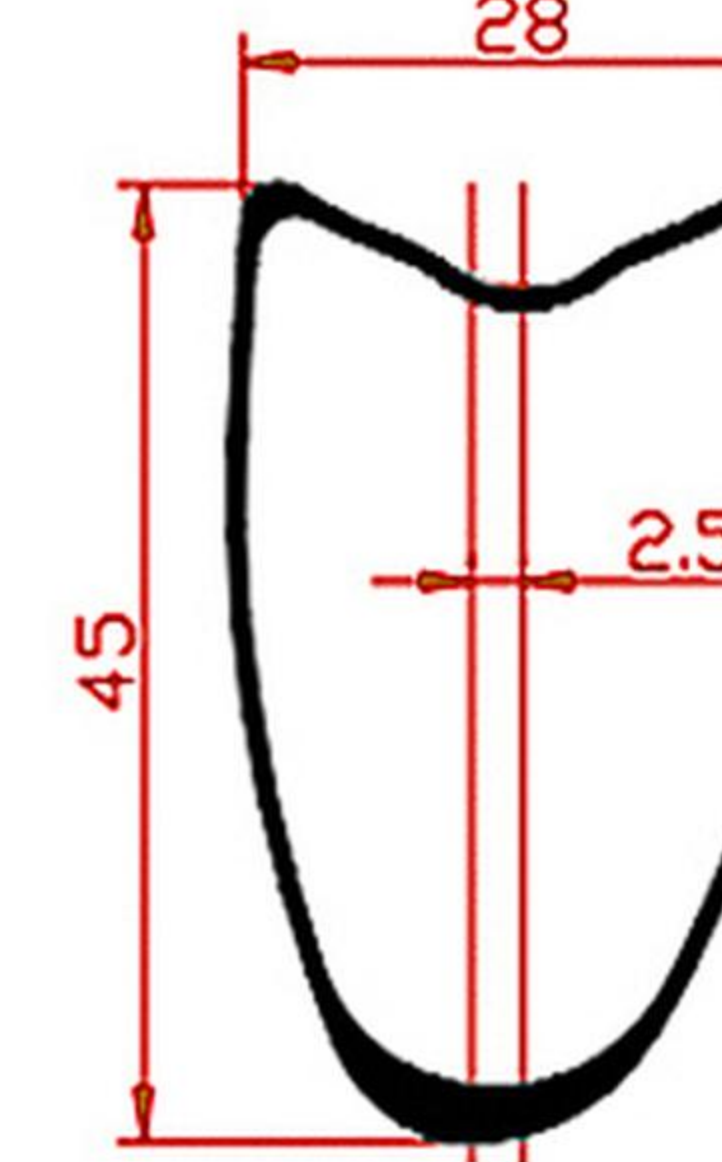

Model: R45T-28-ASY
Weight: T700: 390±15g
T800: 350±15g
ERD: 549

► 28mm Road Asymmetric Rims U-Shape

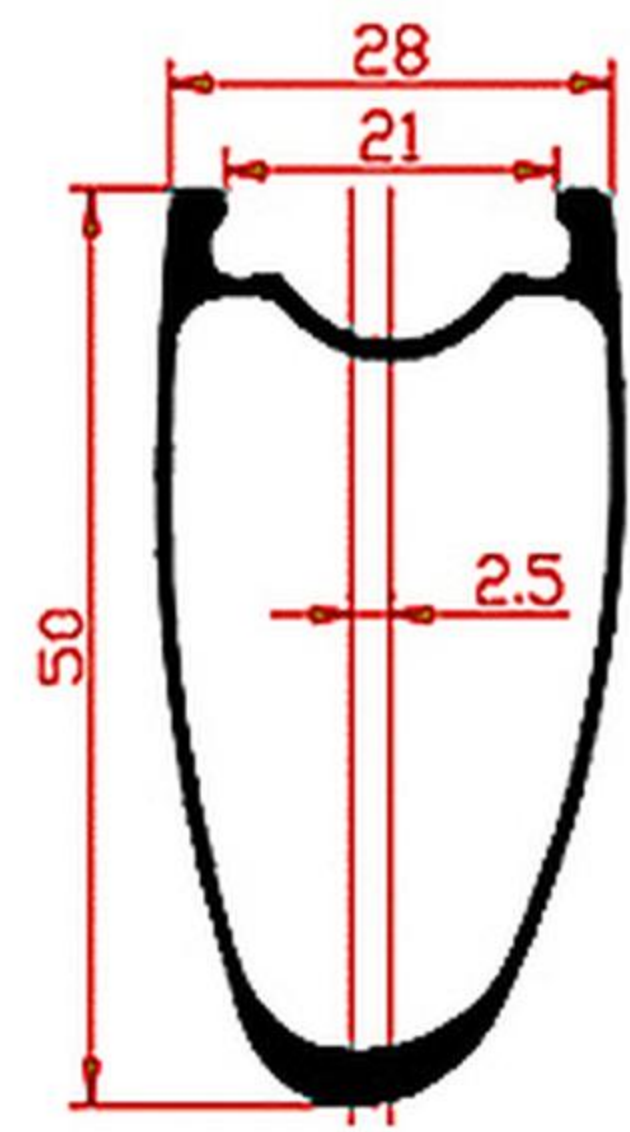

Model: R50TL-28-ASY
Weight: T700: 470±15g
T800: 430±15g
ERD: 549

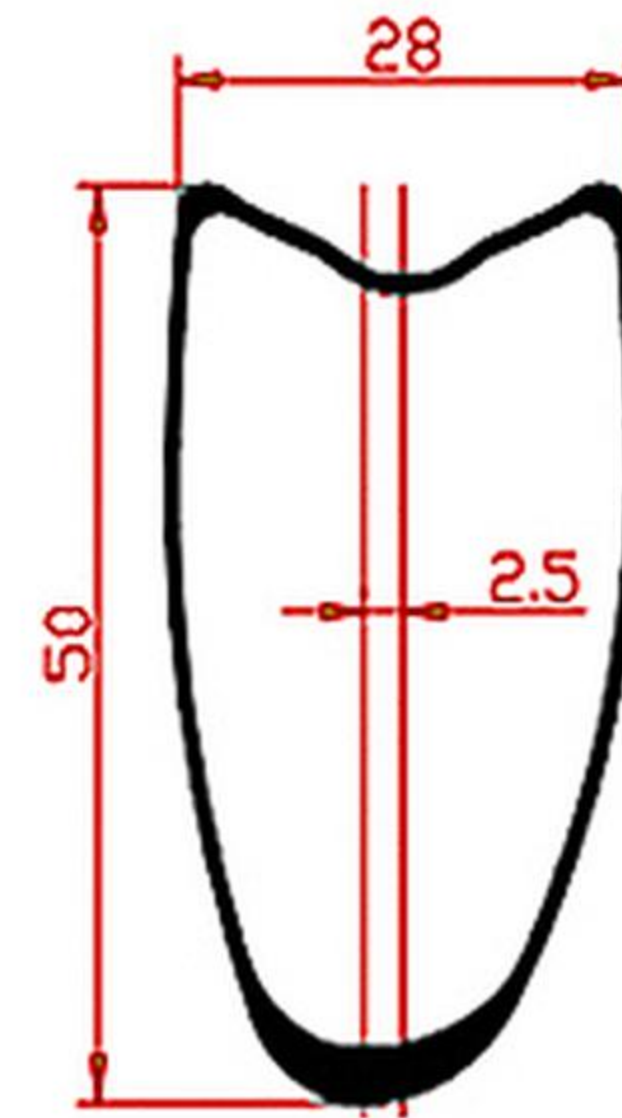

Model: R50T-28-ASY
Weight: T700: 400±15g
T800: 360±15g
ERD: 549

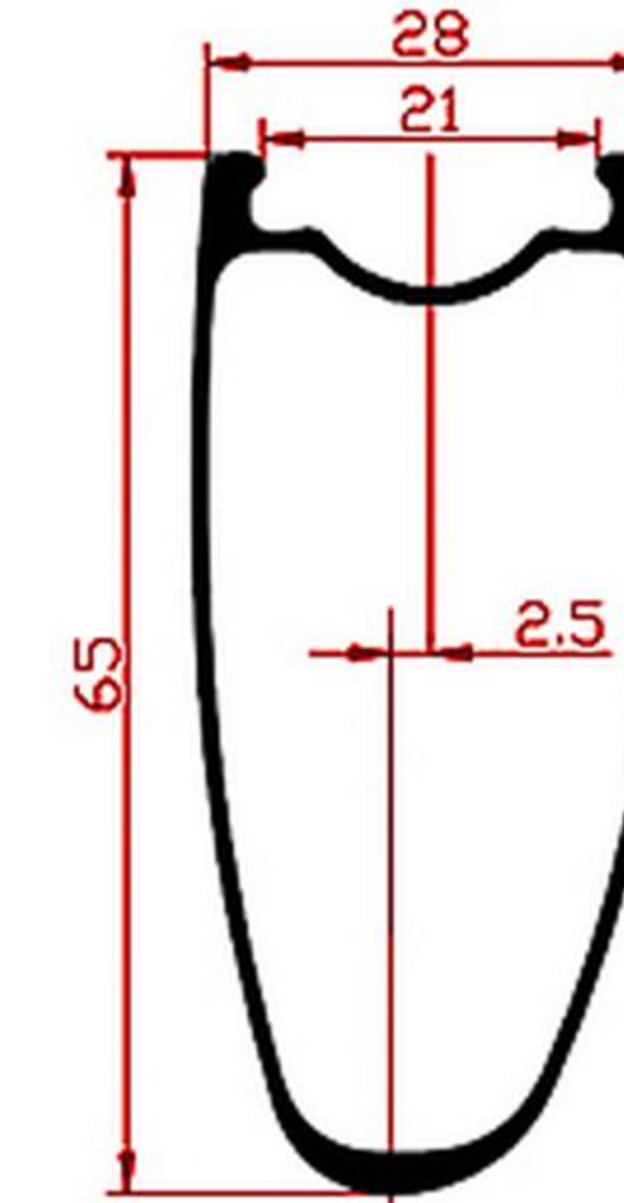

Model: R65TL-28-ASY
Weight: T700: 560±15g
T800: 520±15g
ERD: 509

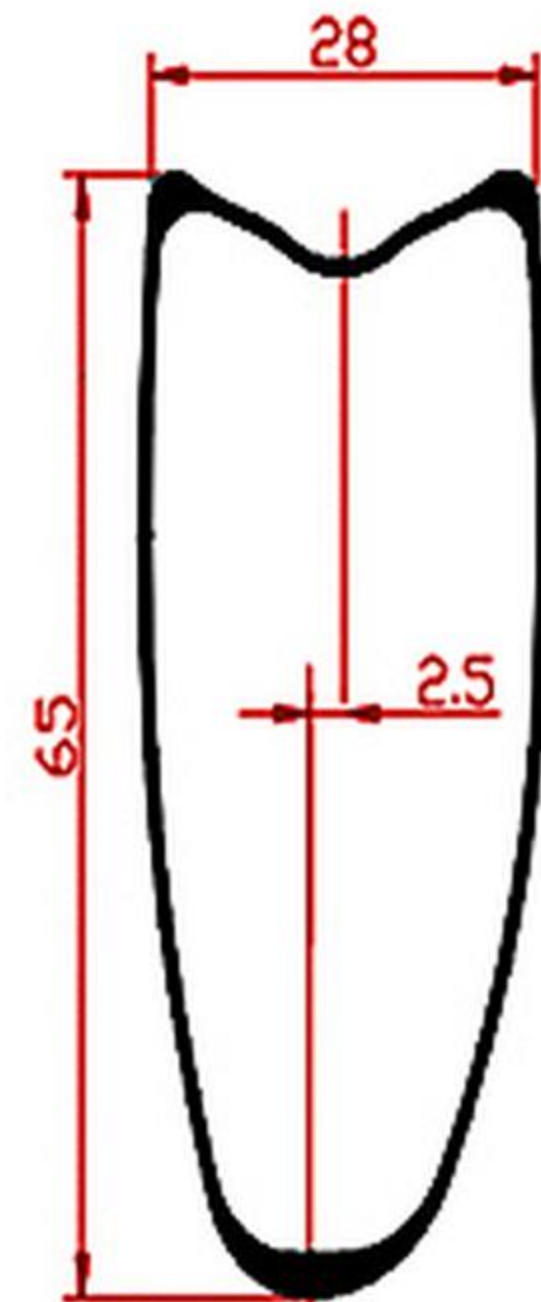

Model: R65T-28-ASY
Weight: T700: 480±15g
T800: 440±15g
ERD: 509

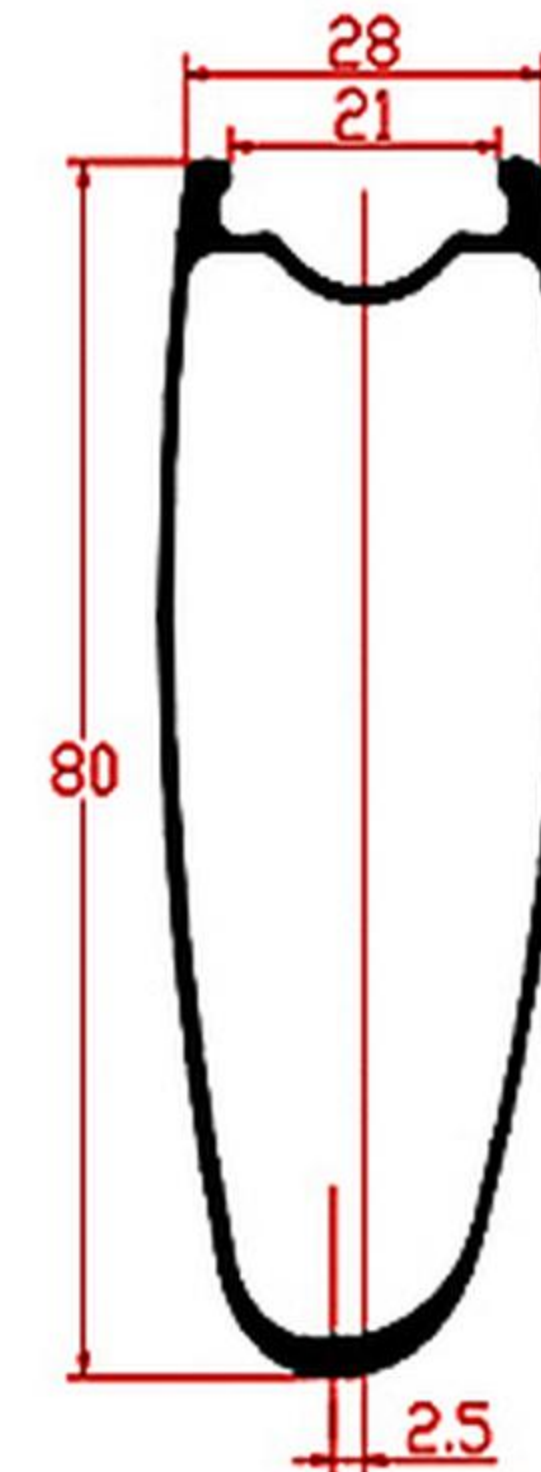

Model: R80TL-28-ASY
Weight: T700: 650±15g
T800: 600±15g
ERD: 479

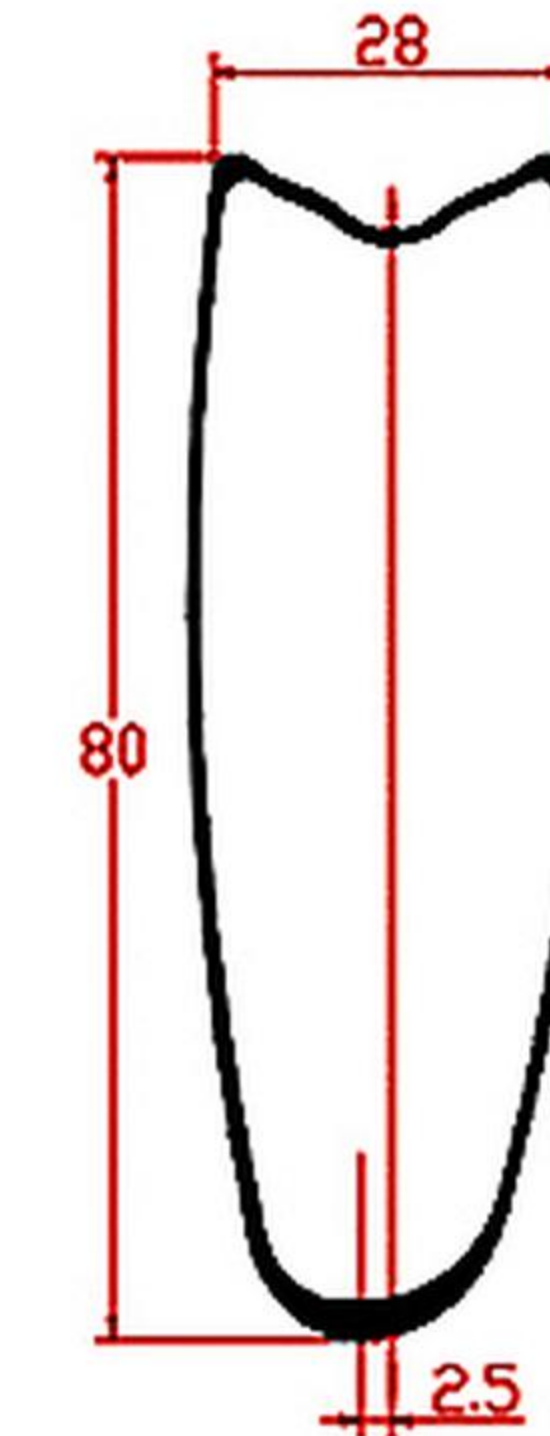

Model: R80T-28-ASY
Weight: T700: 600±15g
T800: 550±15g
ERD: 479

► **31MM Outer Width Gravel**

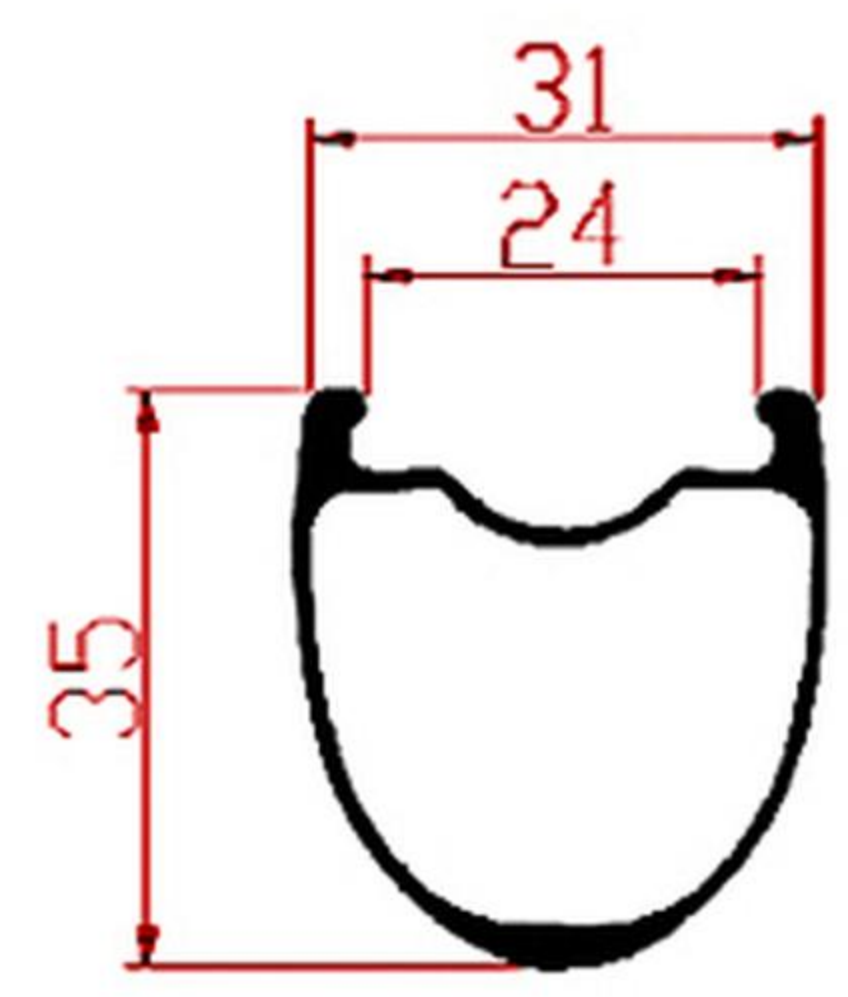

NEW
 Model: G35TL-31
 Weight: 420±15g(T700)
 380±15g(T800)
 340±15g(T800 UL)
 ERD: 569mm

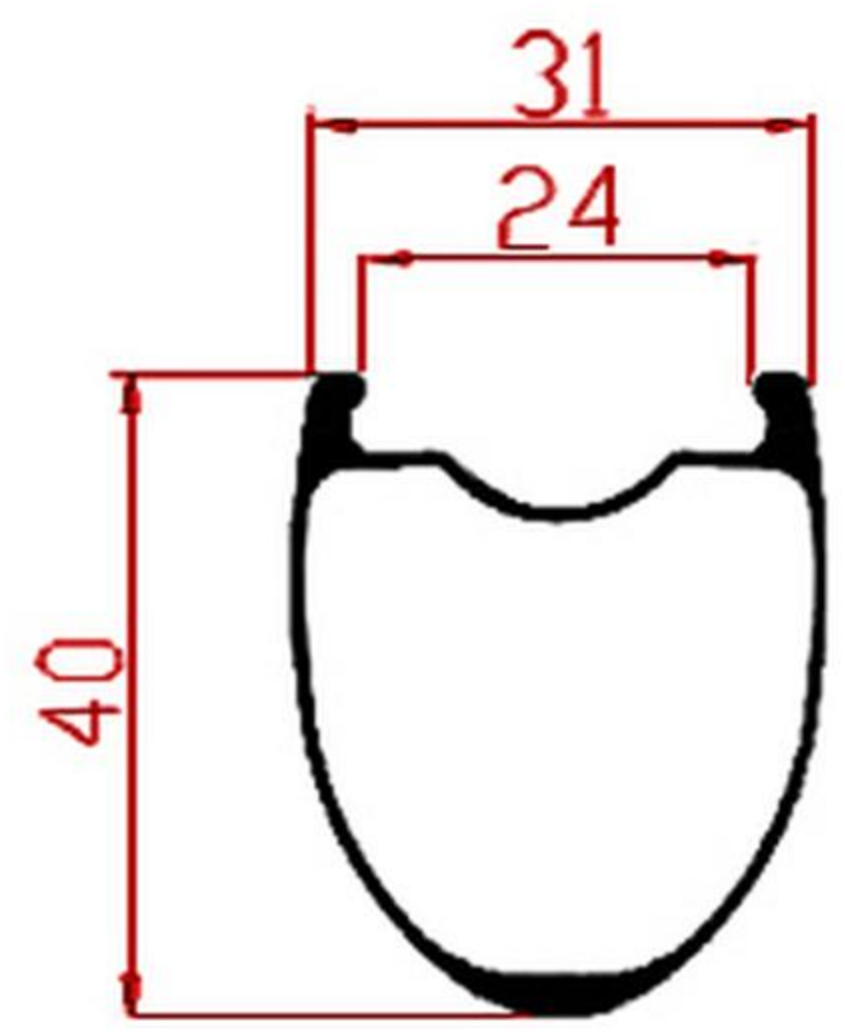

NEW
 Model: G40TL-31
 Weight: 440±15g(T700)
 400±15g(T800)
 360±15g(T800 UL)
 ERD: 559mm

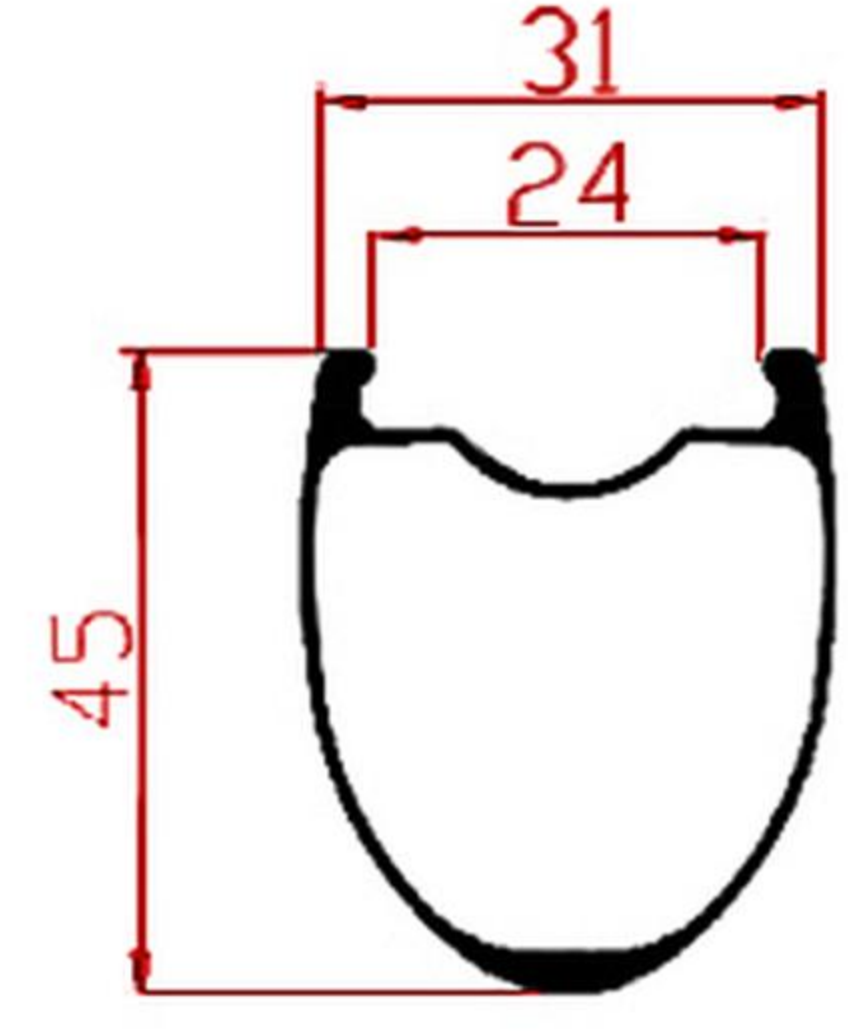

NEW
 Model: G45TL-31
 Weight: 460±15g(T700)
 420±15g(T800)
 380±15g(T800 UL)
 ERD: 549mm

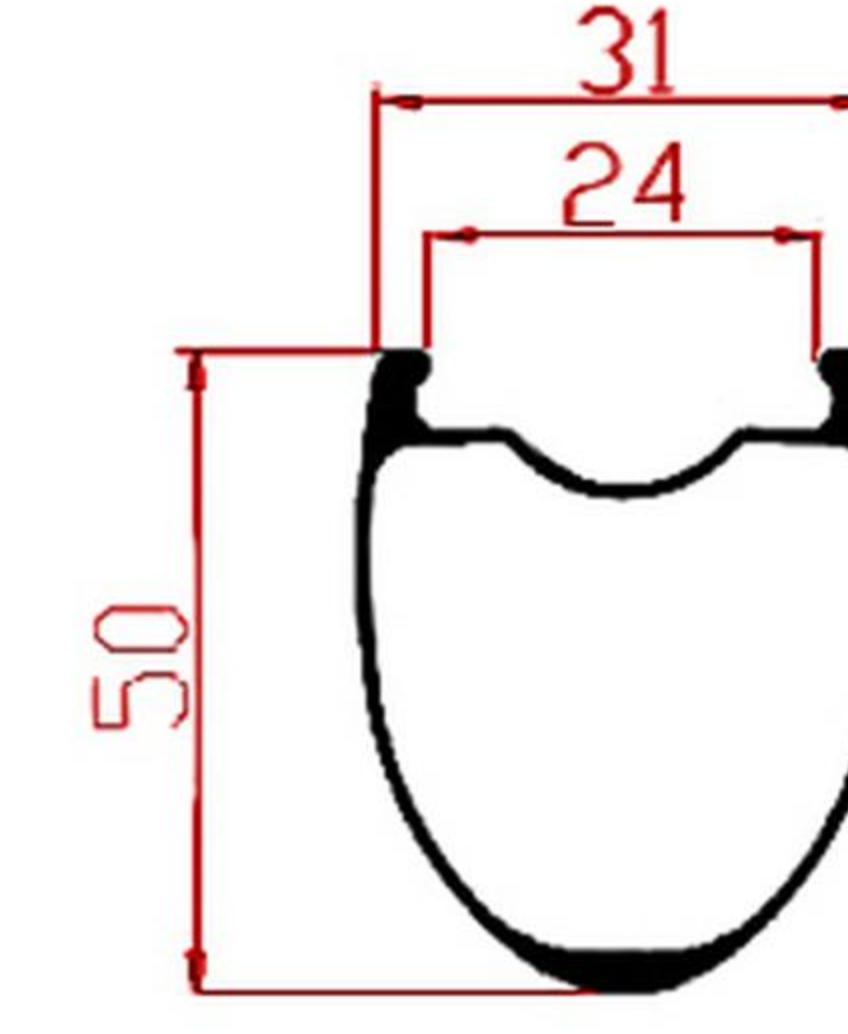

NEW
 Model: G50TL-31
 Weight: 480±15g(T700)
 440±15g(T800)
 400±15g(T800 UL)
 ERD: 539mm

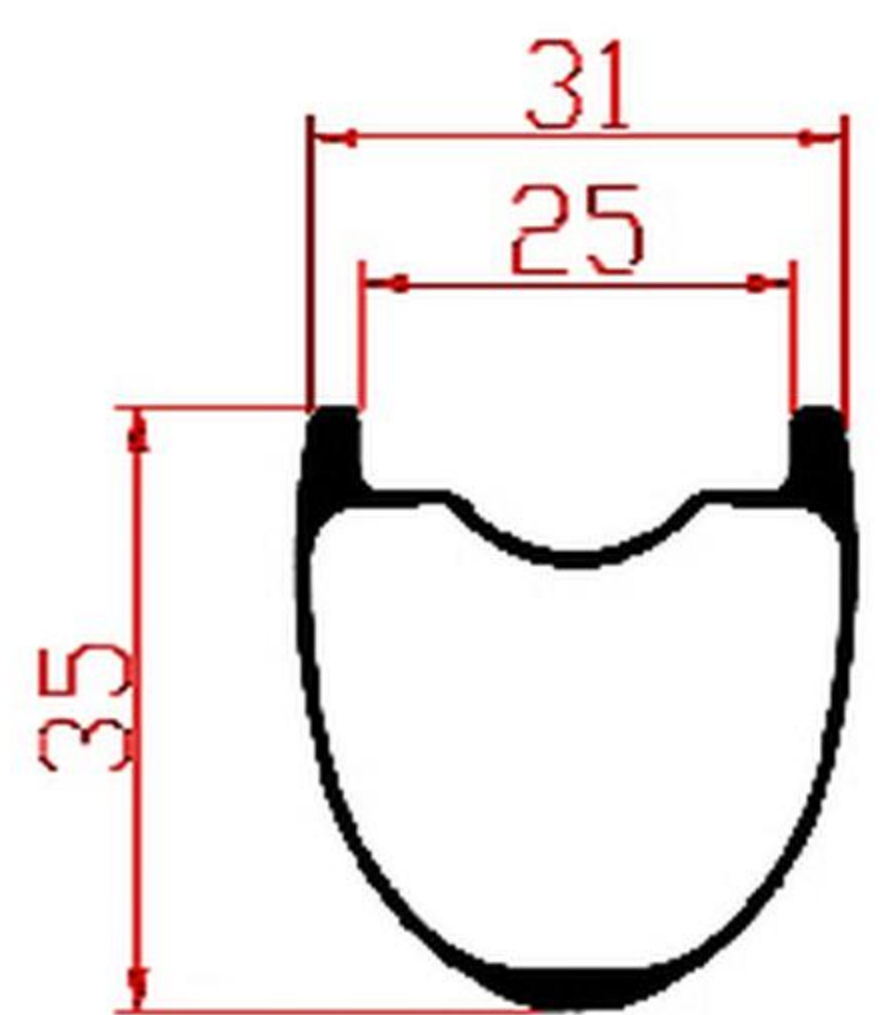

NEW
 Model: G35HL-31
 Weight: 420±15g(T700)
 380±15g(T800)
 340±15g(T800 UL)
 ERD: 569mm

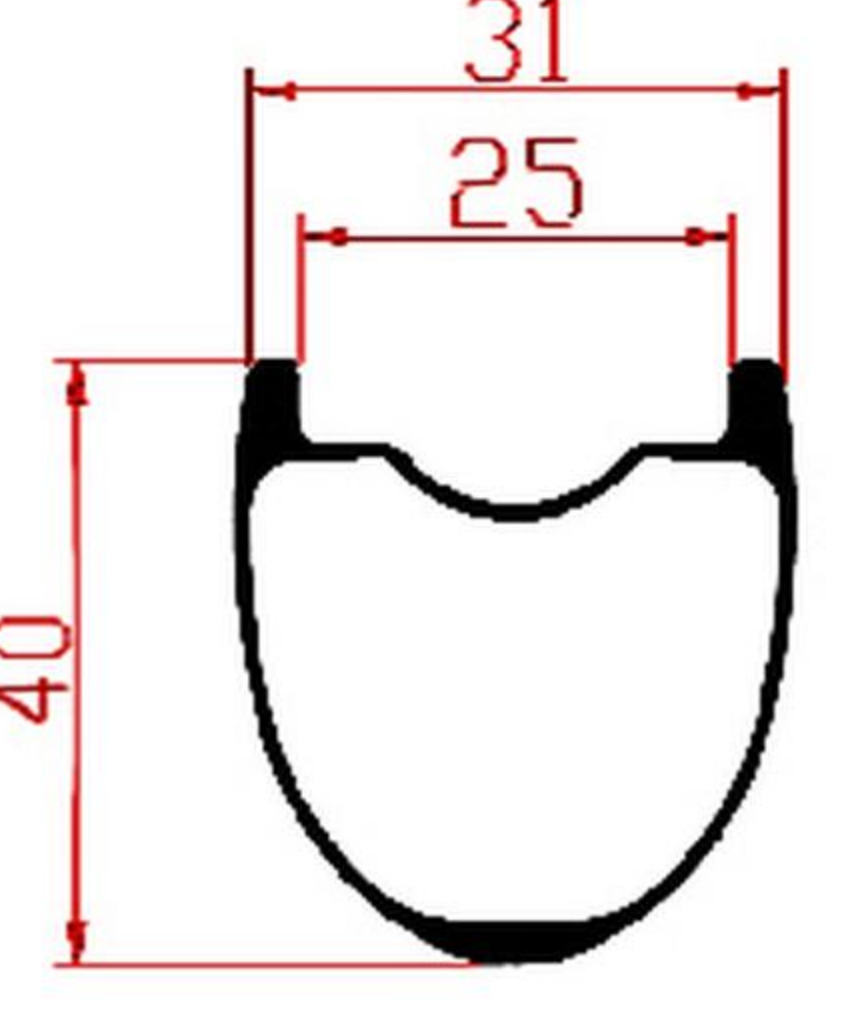

NEW
 Model: G40HL-31
 Weight: 440±15g(T700)
 400±15g(T800)
 360±15g(T800 UL)
 ERD: 559mm

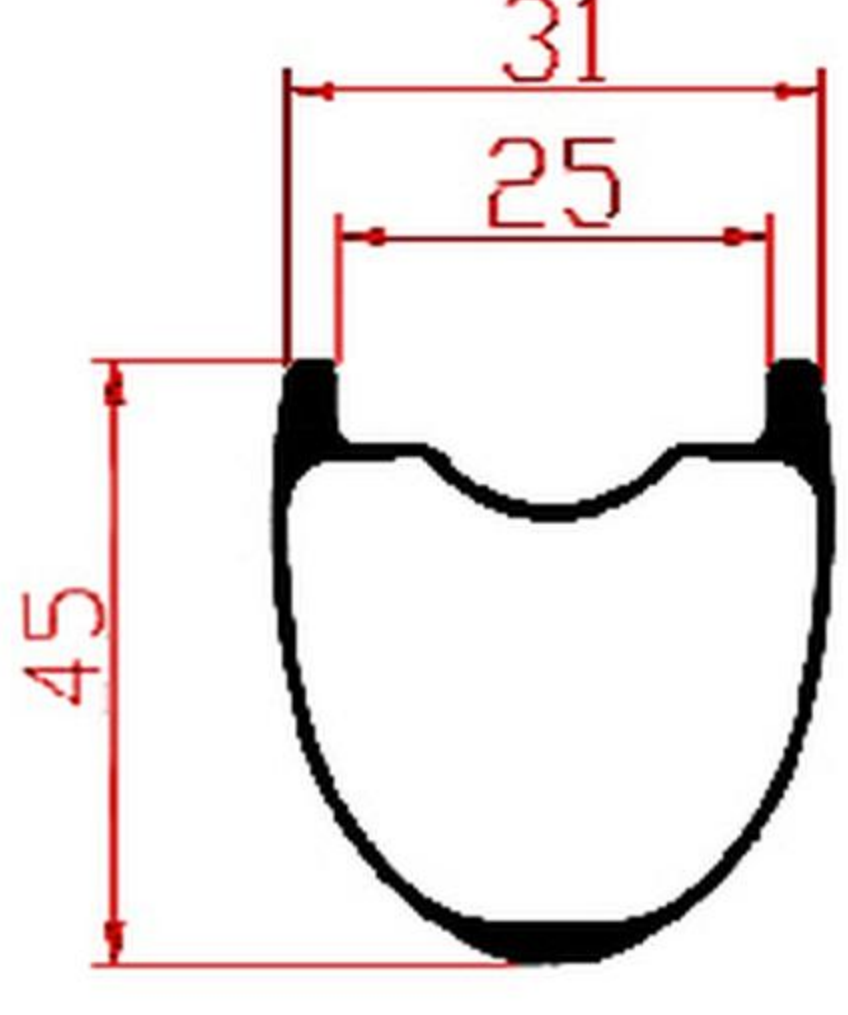

NEW
 Model: G45HL-31
 Weight: 460±15g(T700)
 420±15g(T800)
 380±15g(T800 UL)
 ERD: 549mm

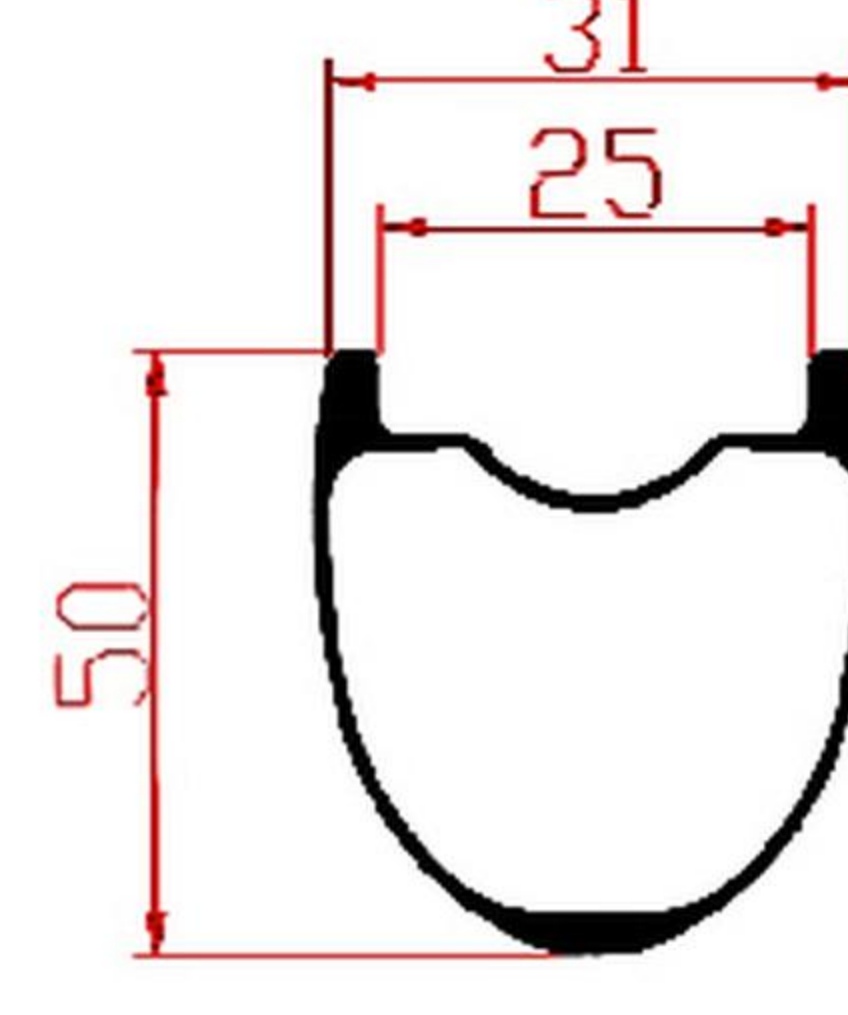

NEW
 Model: G50HL-31
 Weight: 480±15g(T700)
 440±15g(T800)
 400±15g(T800 UL)
 ERD: 539mm

► **31MM Outer Width Gravel Wave Rims(700C)**

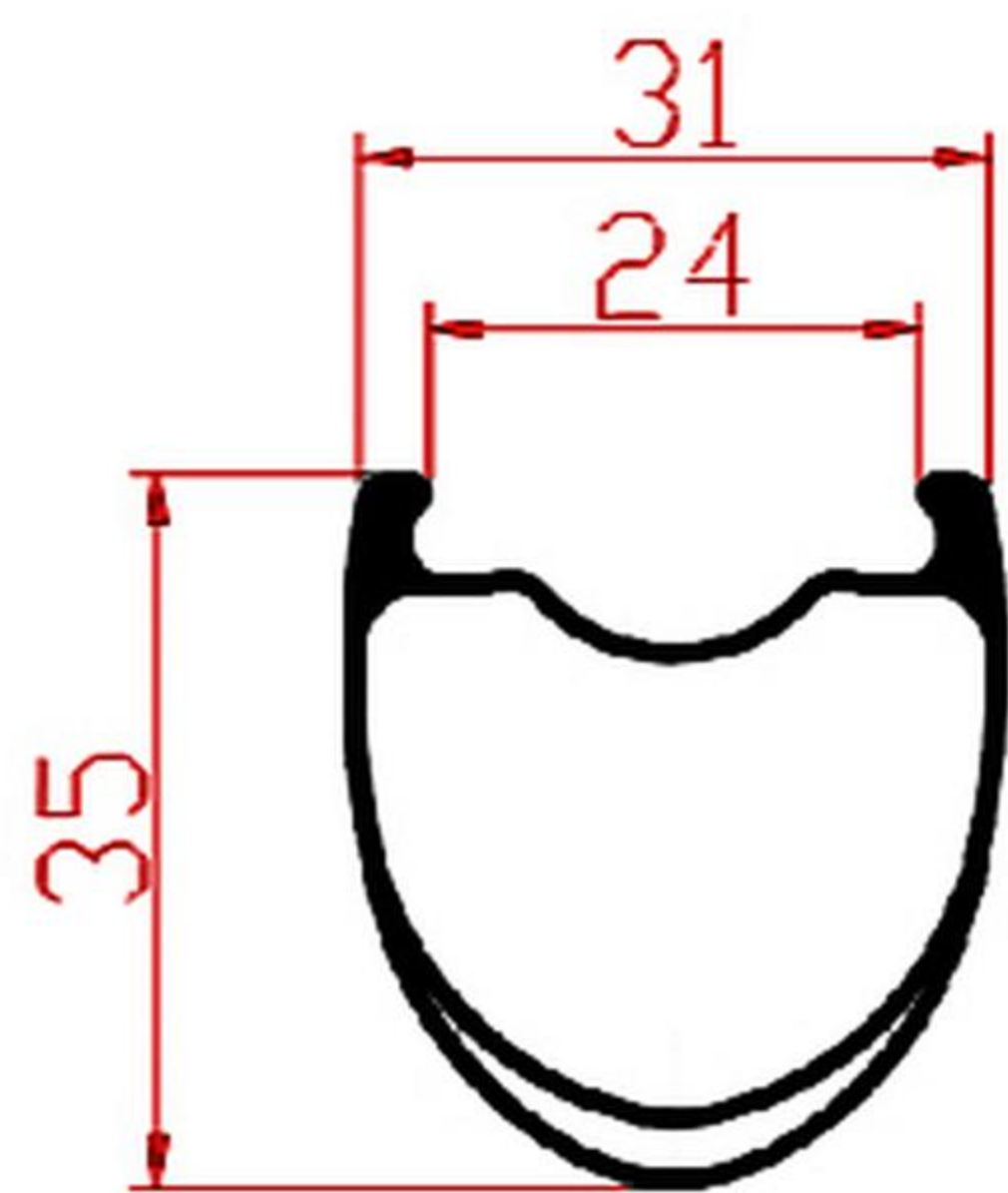

NEW
 Model: W35TL-31
 Weight: 420±15g(T700)
 380±15g(T800)
 340±15g(T800 UL)
 ERD: 569mm

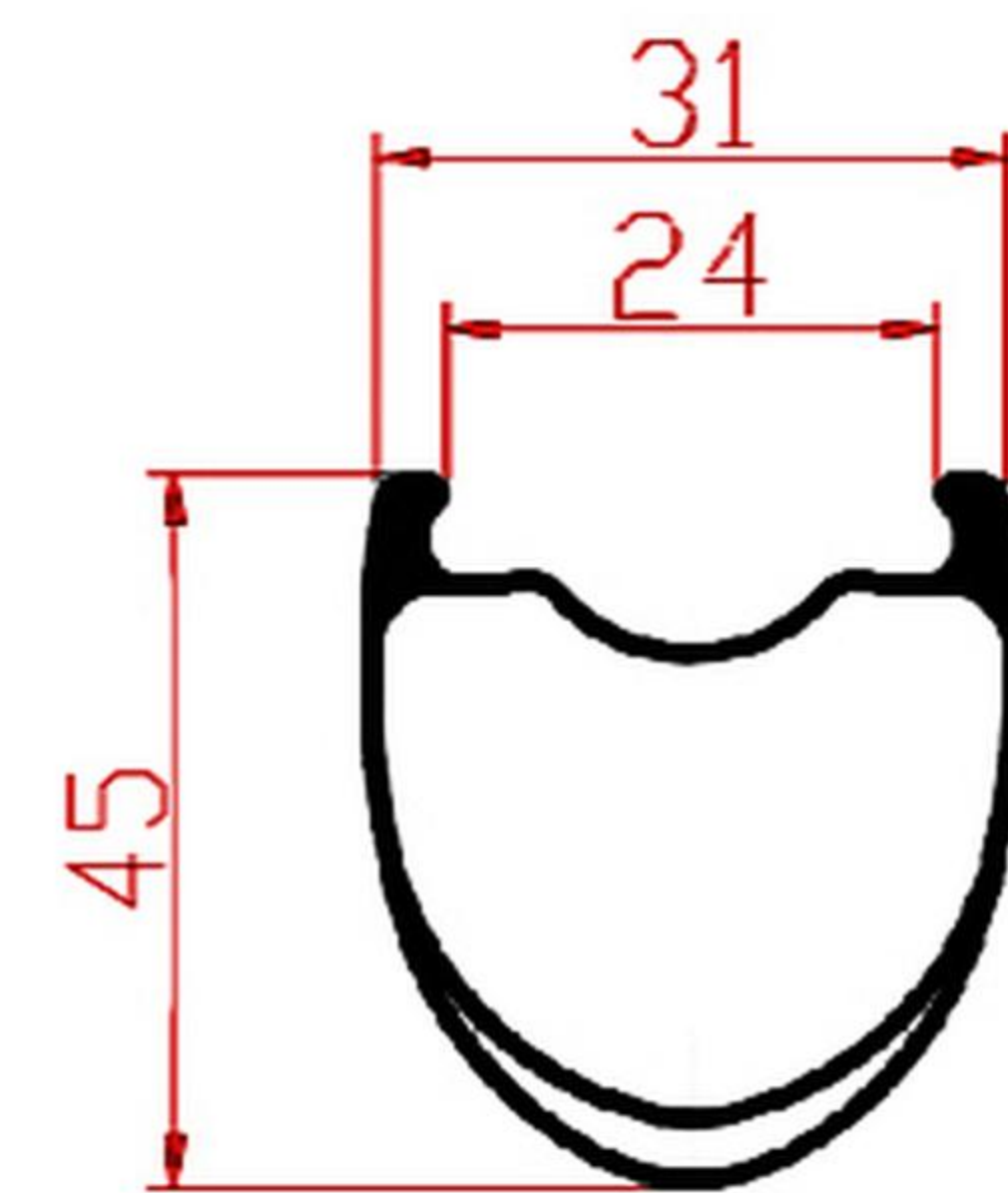

NEW
 Model: W45TL-31
 Weight: 460±15g(T700)
 420±15g(T800)
 380±15g(T800 UL)
 ERD: 549mm

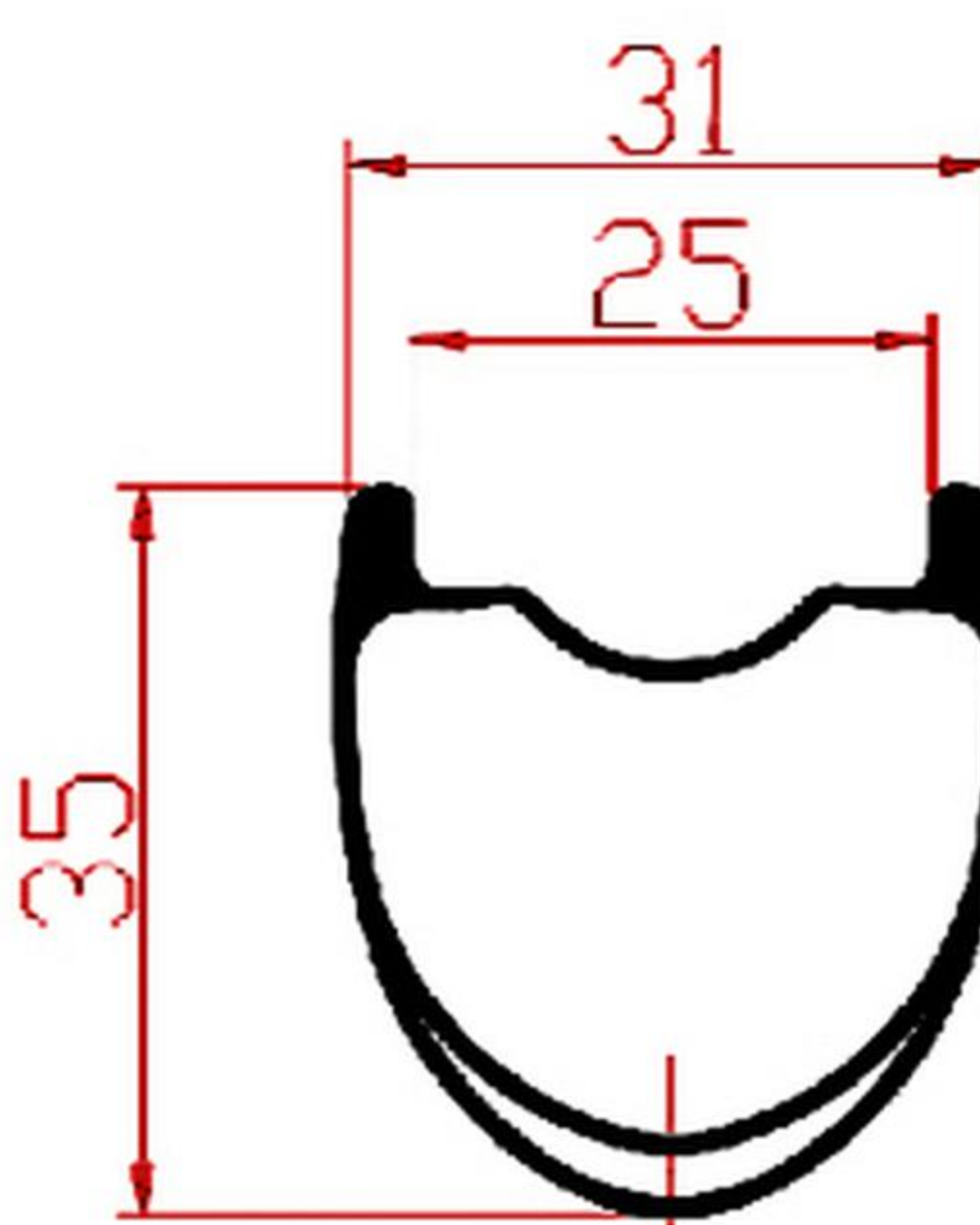

NEW
 Model: W35HL-31
 Weight: 420±15g(T700)
 380±15g(T800)
 340±15g(T800 UL)
 ERD: 569mm

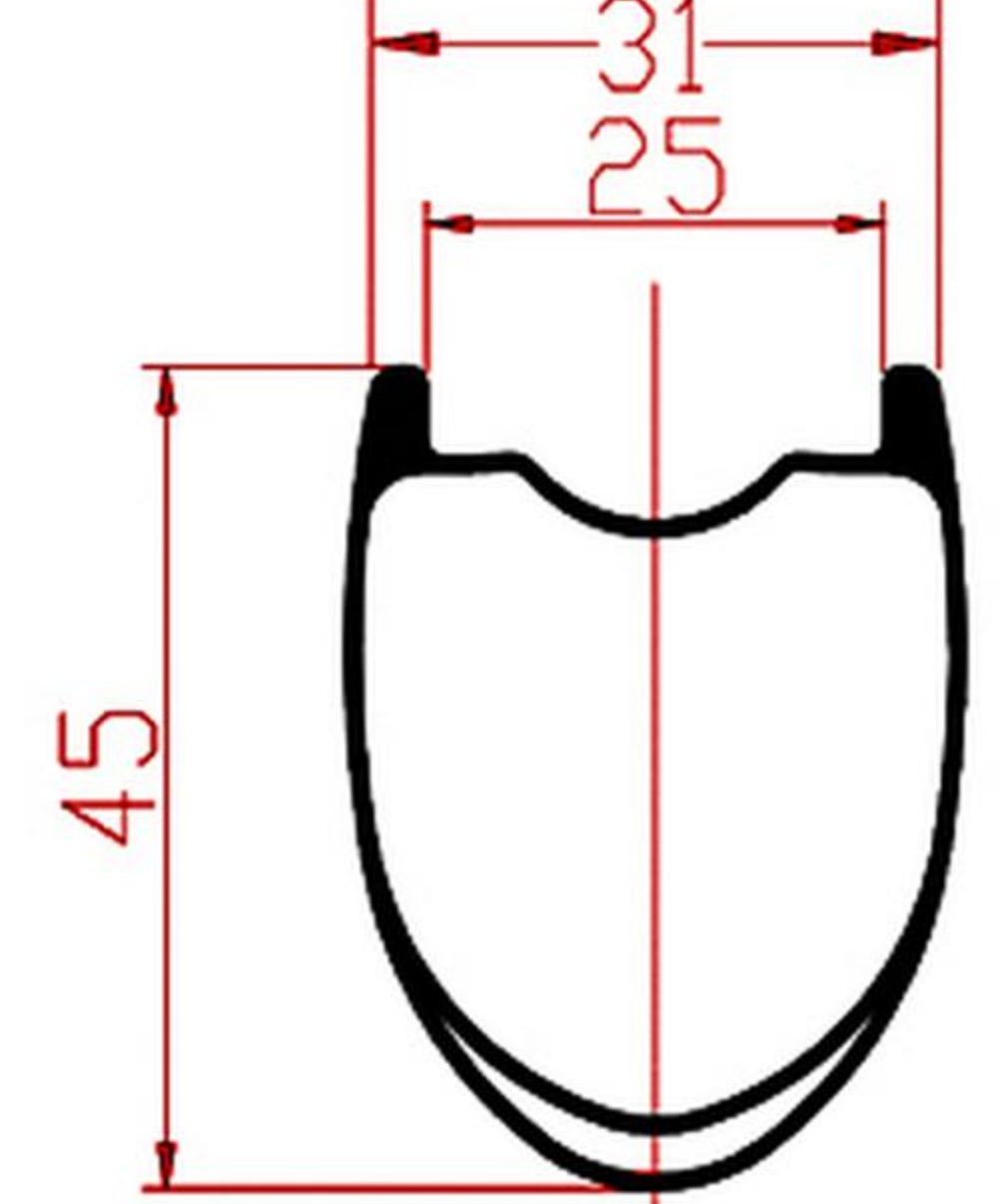

NEW
 Model: W45HL-31
 Weight: 460±15g(T700)
 420±15g(T800)
 380±15g(T800 UL)
 ERD: 549mm

► 32MM Gravel Road Rims Asymmetric

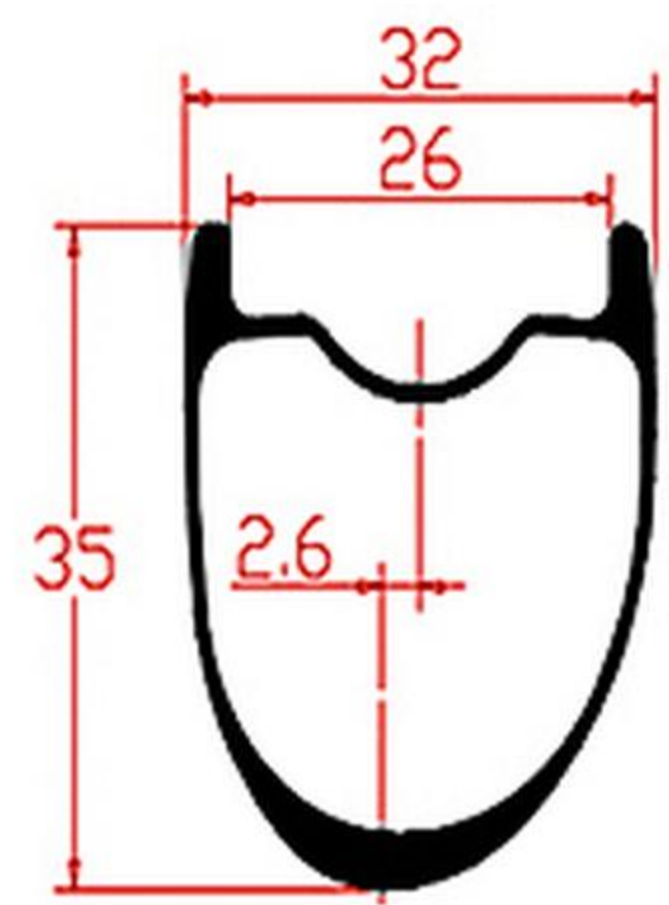

Model: G35HL-32
Weight: T700: 420±15g
T800: 380±15g
ERD: 569

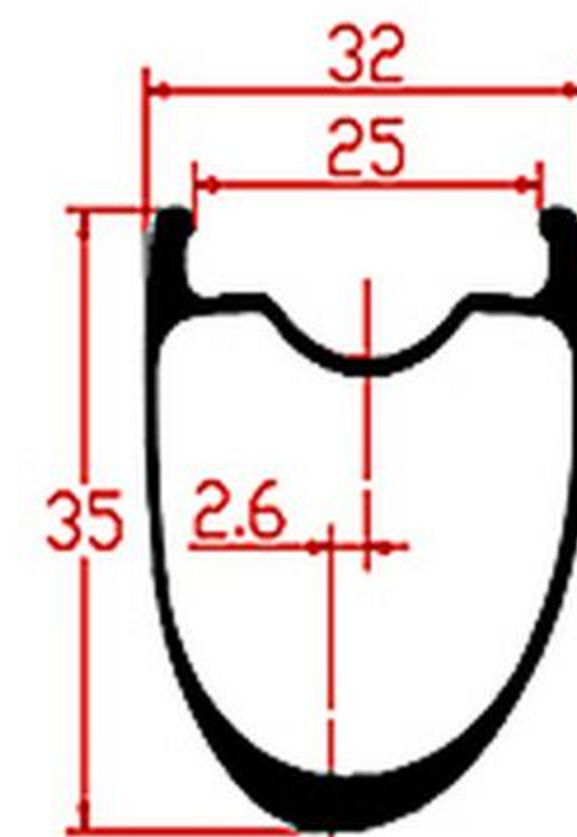

Model: G35TL-32
Weight: T700: 420±15g
T800: 380±15g
ERD: 569

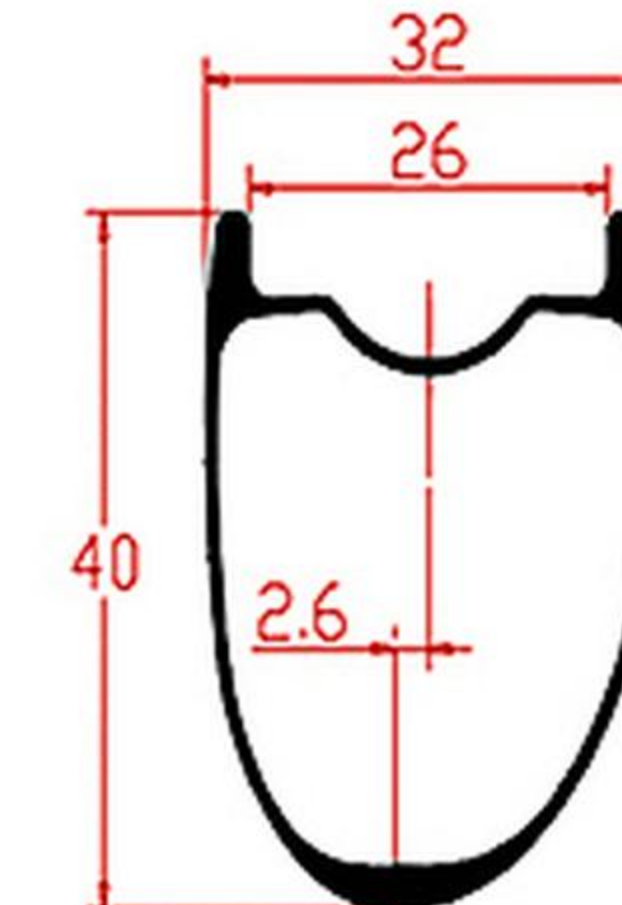

Model: G40HL-32
Weight: T700: 440±15g
T800: 400±15g
ERD: 559

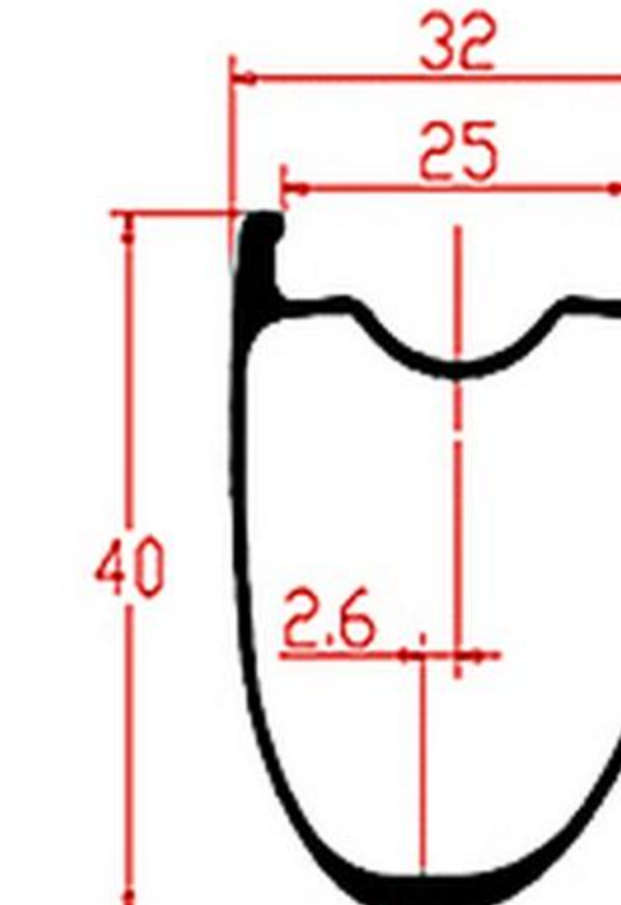

Model: G40TL-32
Weight: T700: 440±15g
T800: 400±15g
ERD: 559

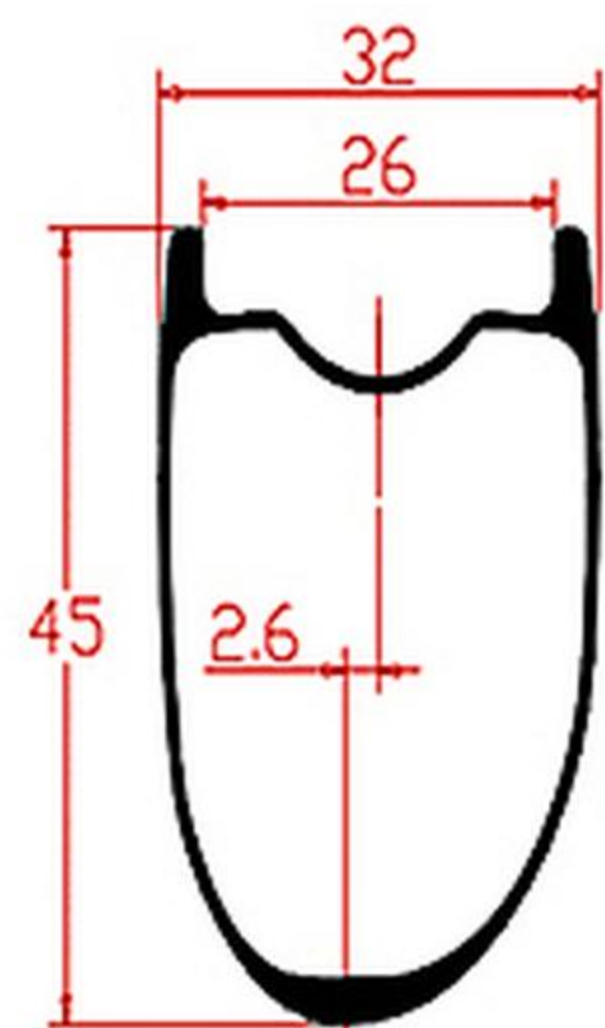

Model: G45HL-32
Weight: T700: 460±15g
T800: 420±15g
ERD: 549

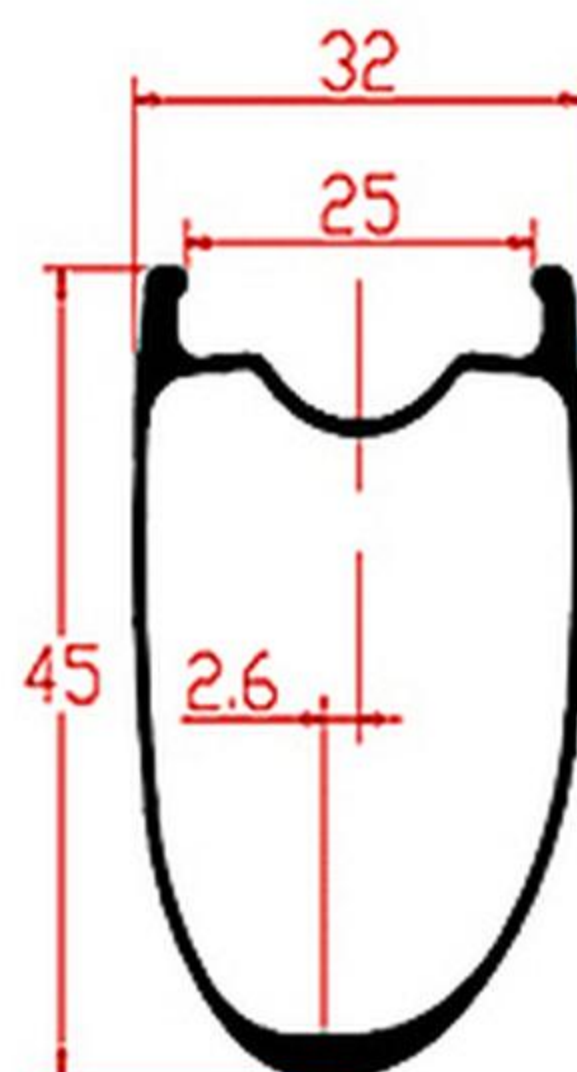

Model: G45TL-32
Weight: T700: 460±15g
T800: 420±15g
ERD: 549

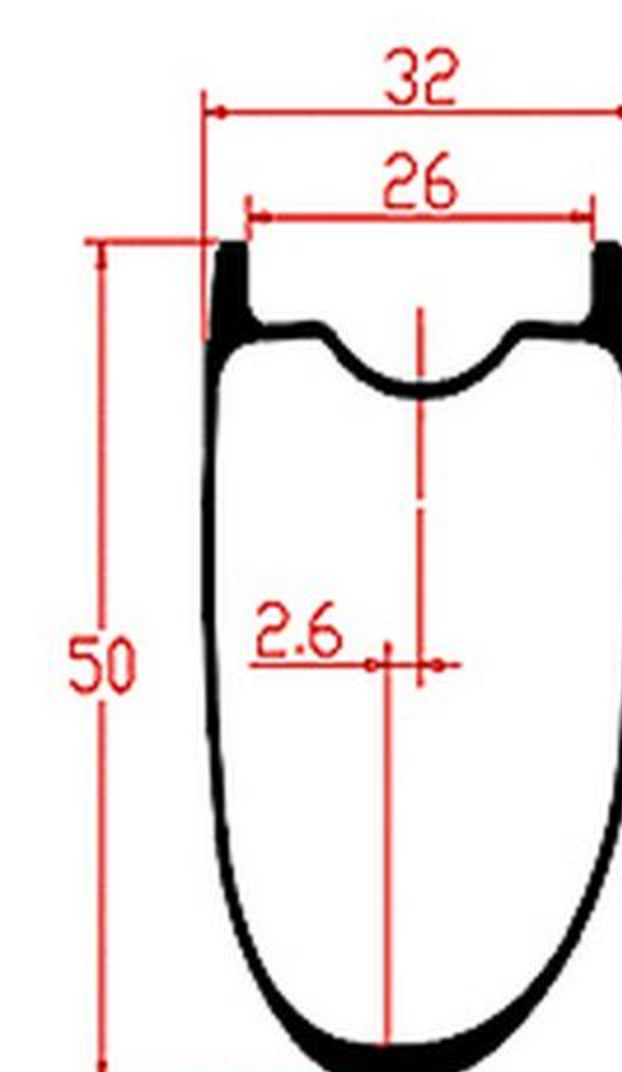

Model: G50HL-32
Weight: T700: 480±15g
T800: 440±15g
ERD: 539

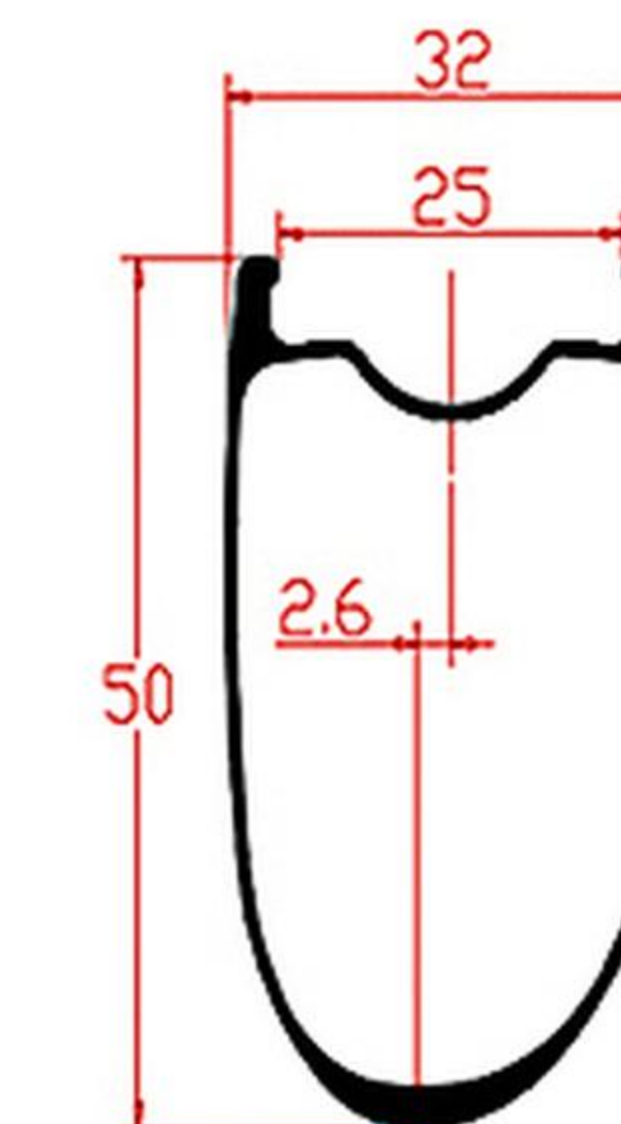

Model: G50TL-32
Weight: T700: 480±15g
T800: 440±15g
ERD: 539

► **36MM Outer Width Gravel Rims(700C)**

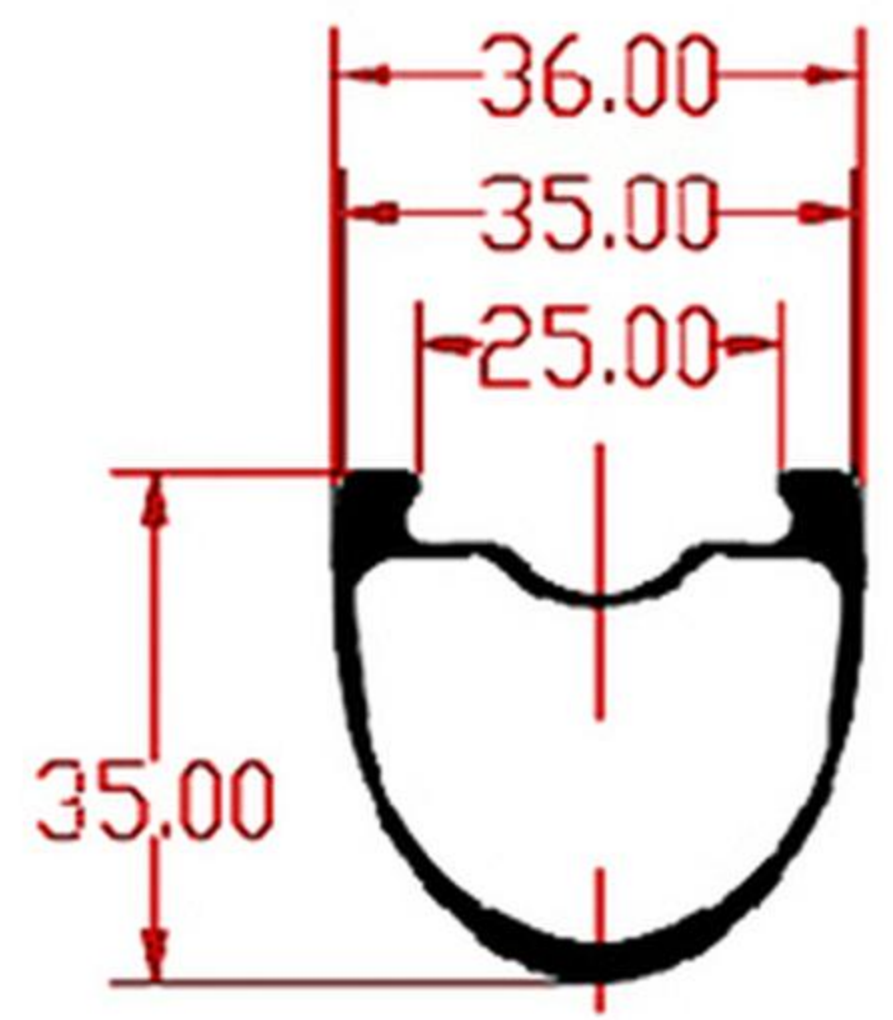

NEW

Model: G35TL-36-TH
Weight: 440±15g(T700)
400±15g(T800)
375±15g(T800 UL)
ERD: 569mm

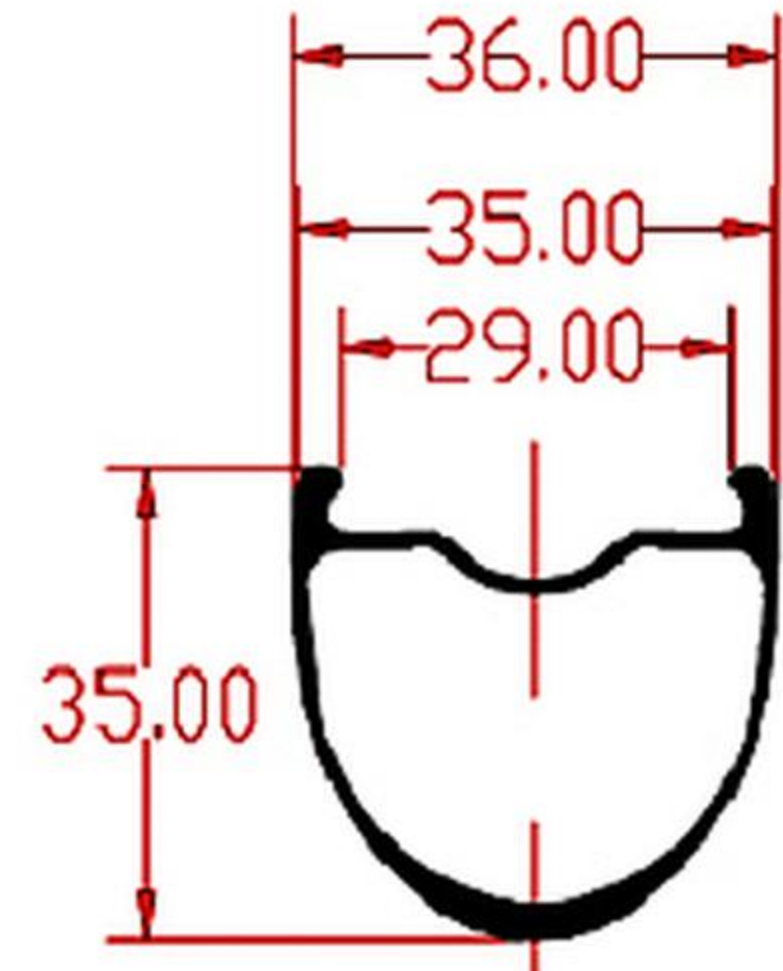

NEW

Model: G35TL-36
Weight: 420±15g(T700)
380±15g(T800)
355±15g(T800 UL)
ERD: 569mm

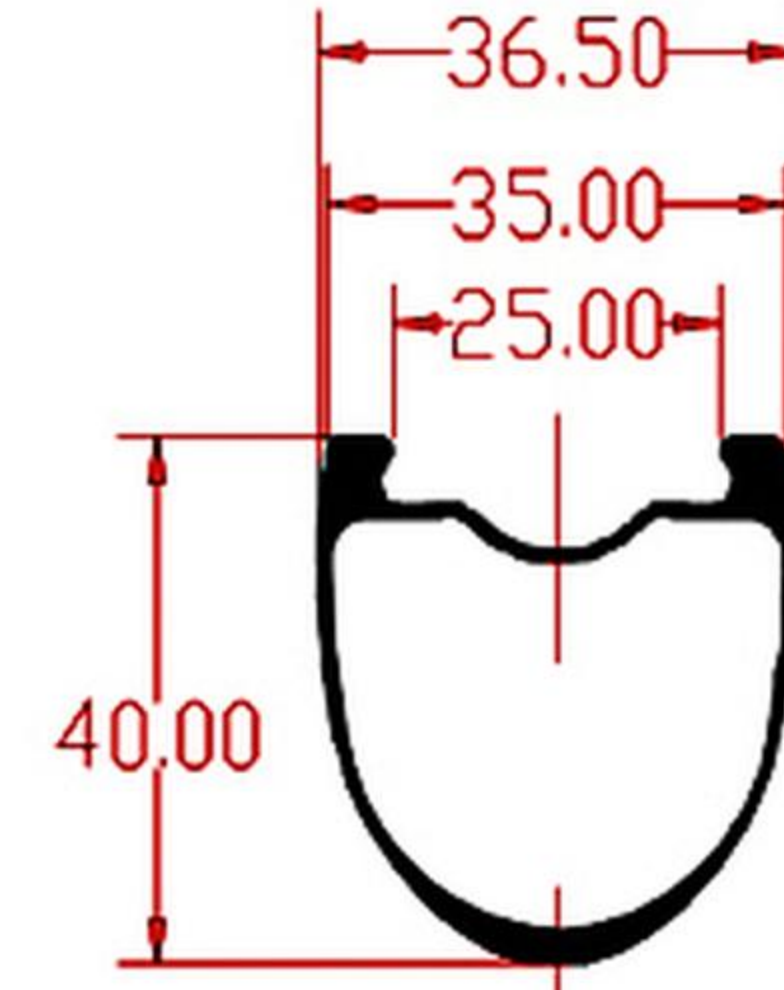

NEW

Model: G40TL-36-TH
Weight: 460±15g(T700)
420±15g(T800)
395±15g(T800 UL)
ERD: 559mm

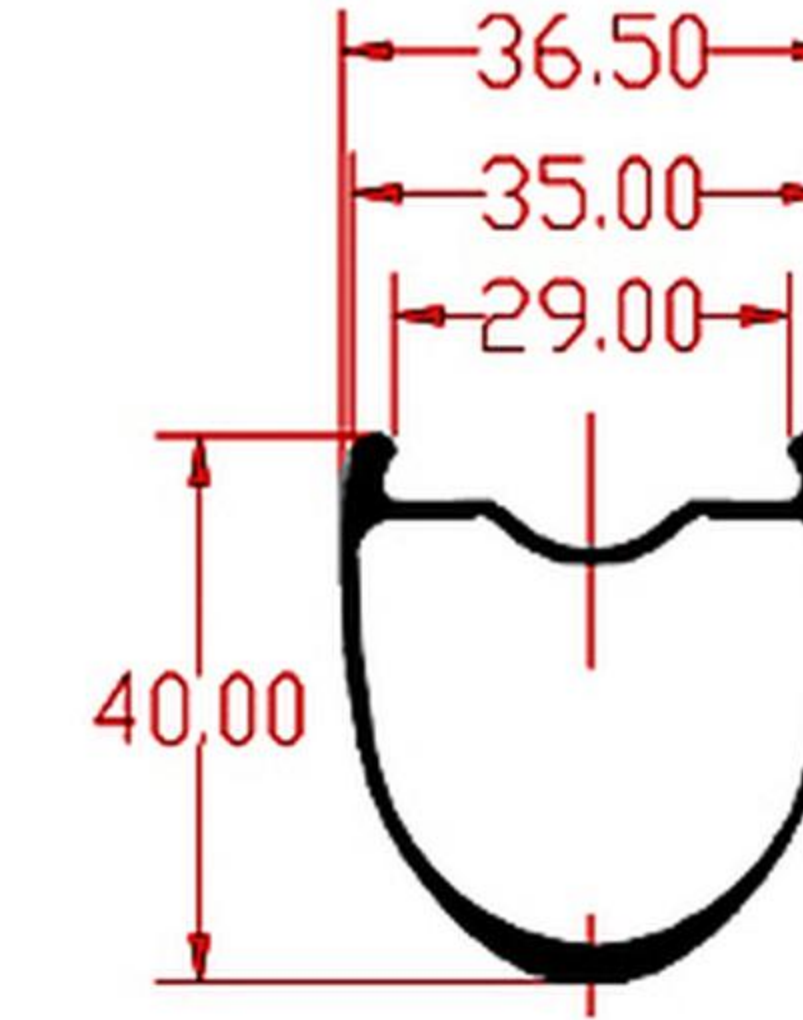

NEW

Model: G40TL-36
Weight: 440±15g(T700)
400±15g(T800)
375±15g(T800 UL)
ERD: 559mm

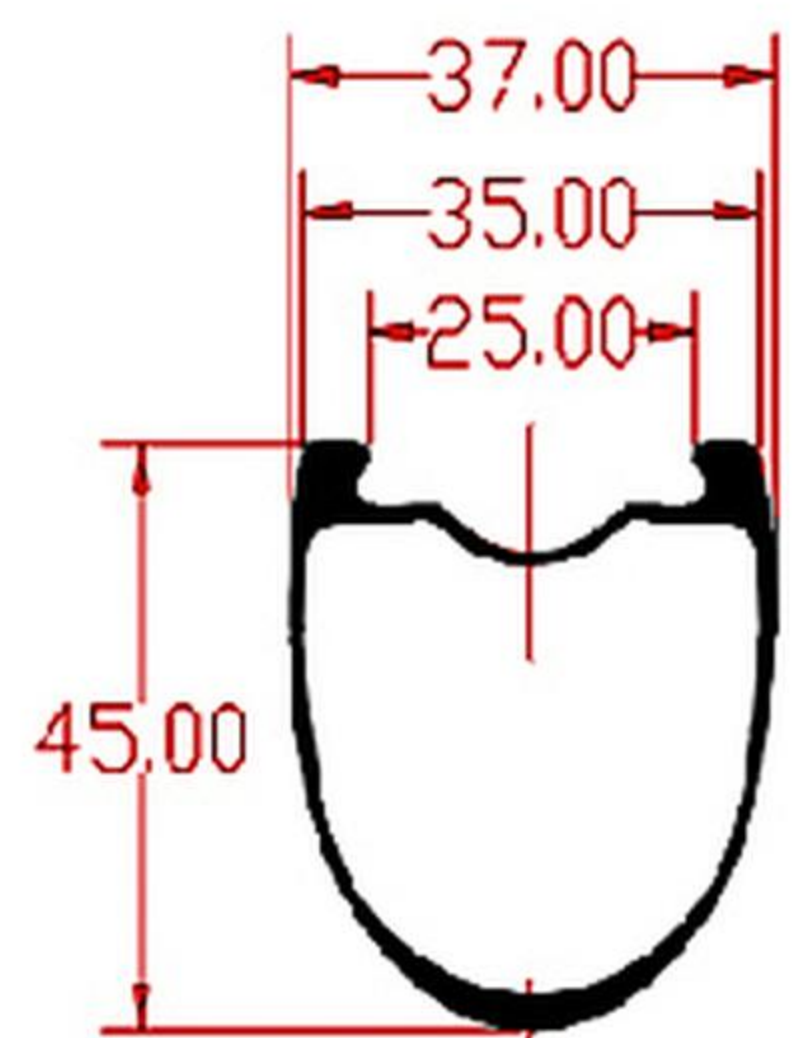

NEW

Model: G45TL-36-TH
Weight: 480±15g(T700)
440±15g(T800)
415±15g(T800 UL)
ERD: 549mm

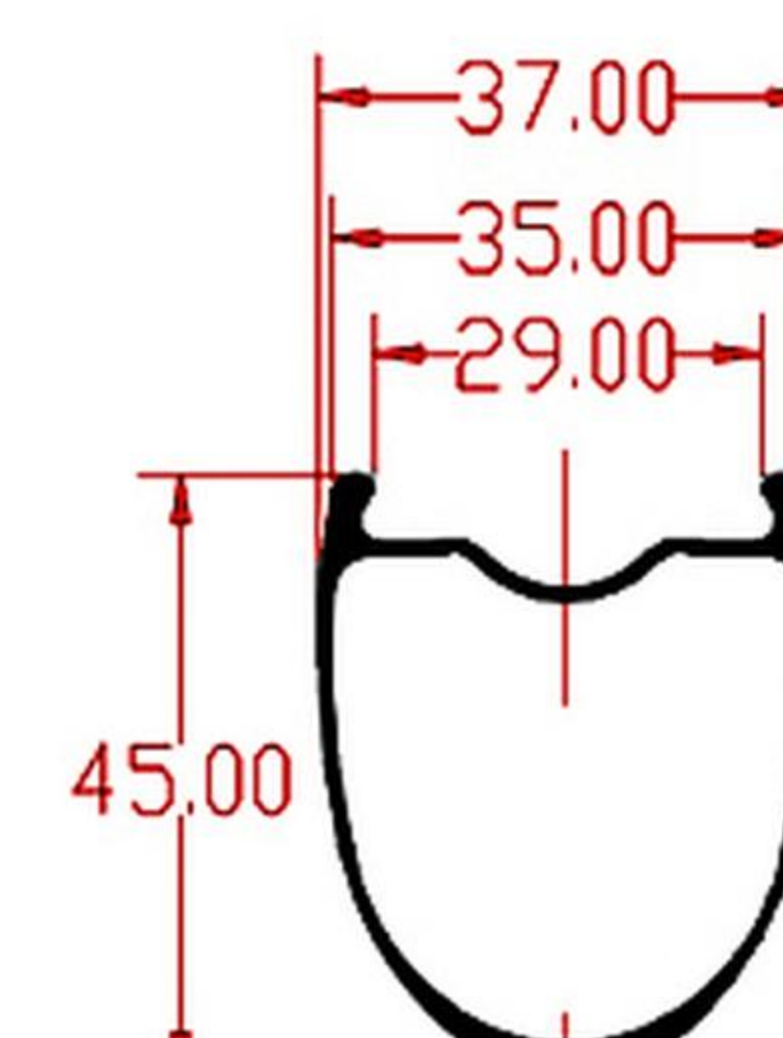

NEW

Model: G45TL-36
Weight: 460±15g(T700)
420±15g(T800)
395±15g(T800 UL)
ERD: 549mm

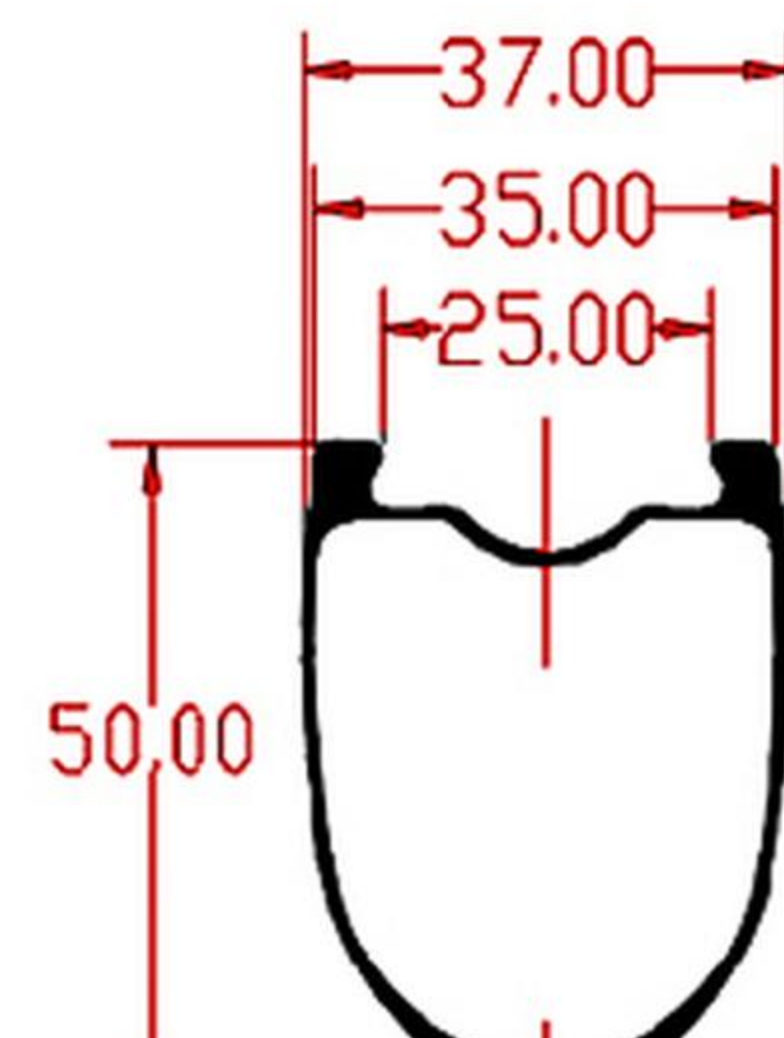

NEW

Model: G50TL-36-TH
Weight: 500±15g(T700)
480±15g(T800)
435±15g(T800 UL)
ERD: 539mm

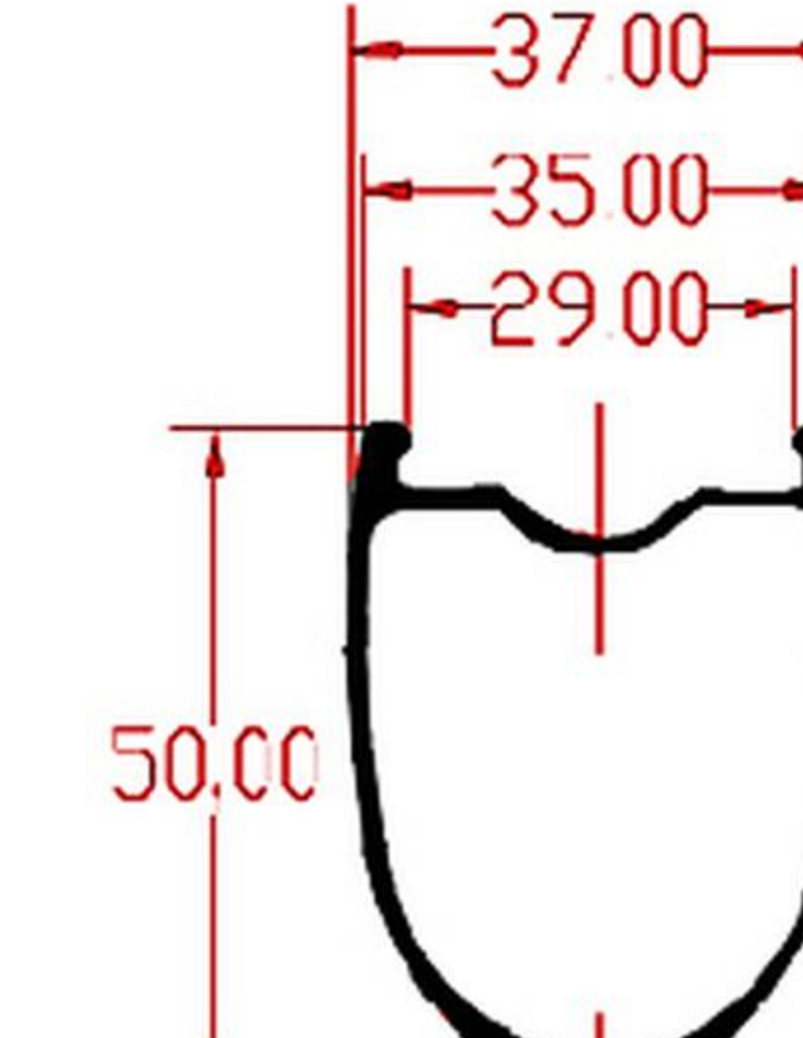

NEW

Model: G50TL-36
Weight: 480±15g(T700)
440±15g(T800)
415±15g(T800 UL)
ERD: 539mm

► **36MM Outer Width Gravel Rims(700C)**

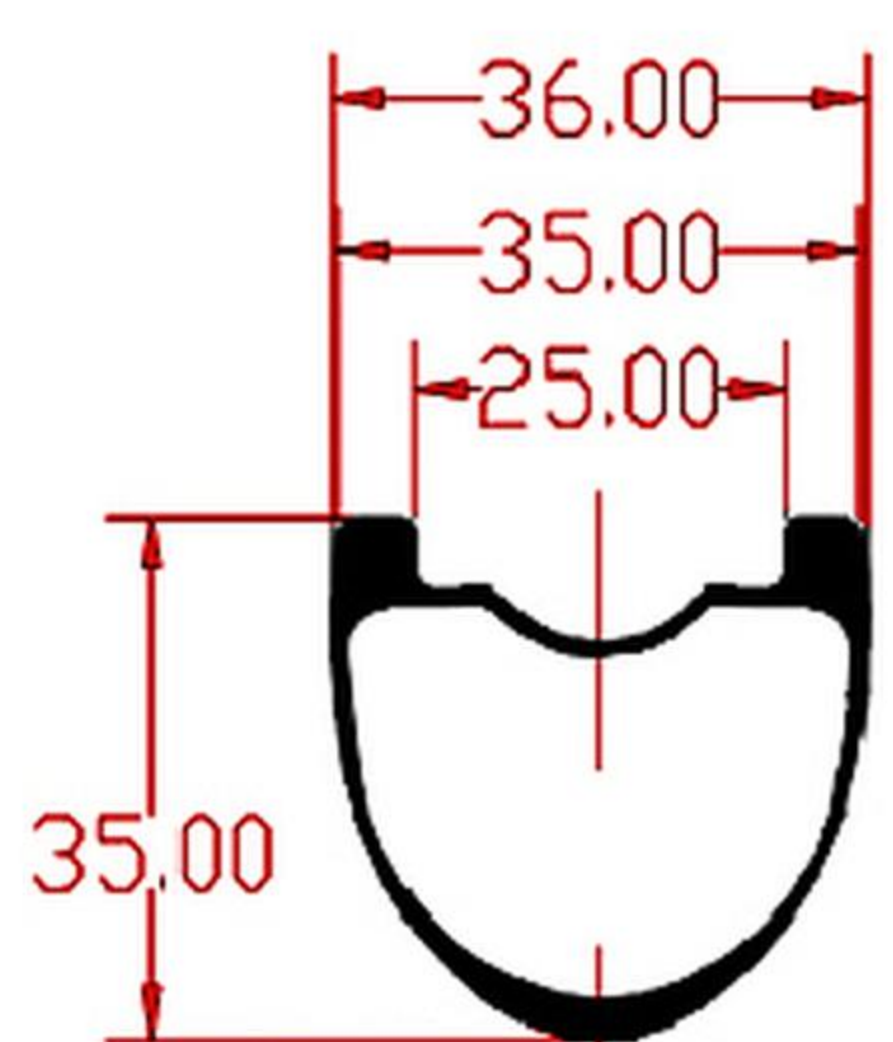

NEW

Model: G35HL-36-TH
Weight: 420±15g(T700)
380±15g(T800)
355±15g(T800 UL)
ERD: 569mm

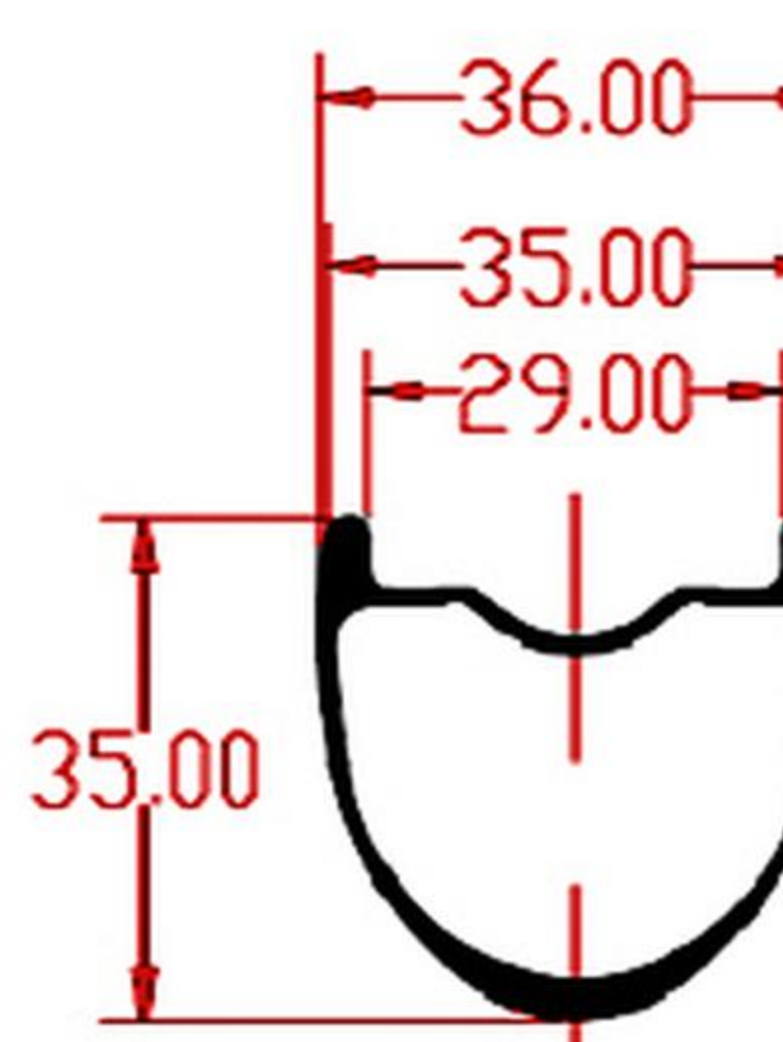

NEW

Model: G35HL-36
Weight: 420±15g(T700)
380±15g(T800)
355±15g(T800 UL)
ERD: 569mm

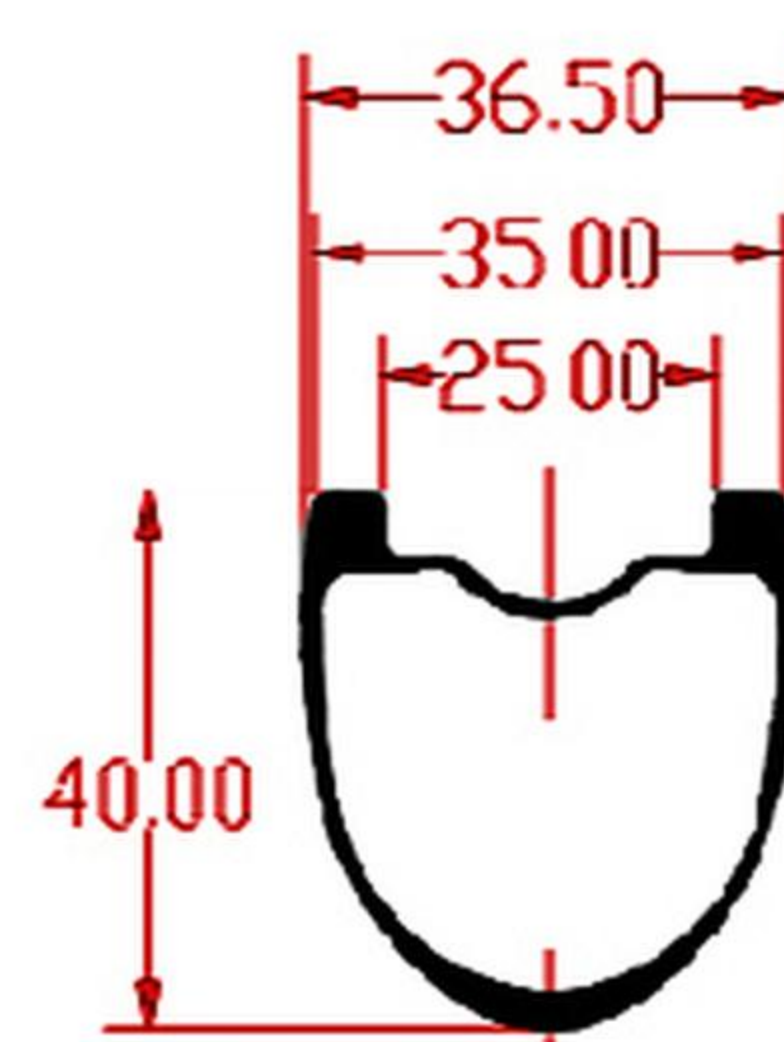

NEW

Model: G40HL-36-TH
Weight: 460±15g(T700)
420±15g(T800)
395±15g(T800 UL)
ERD: 559mm

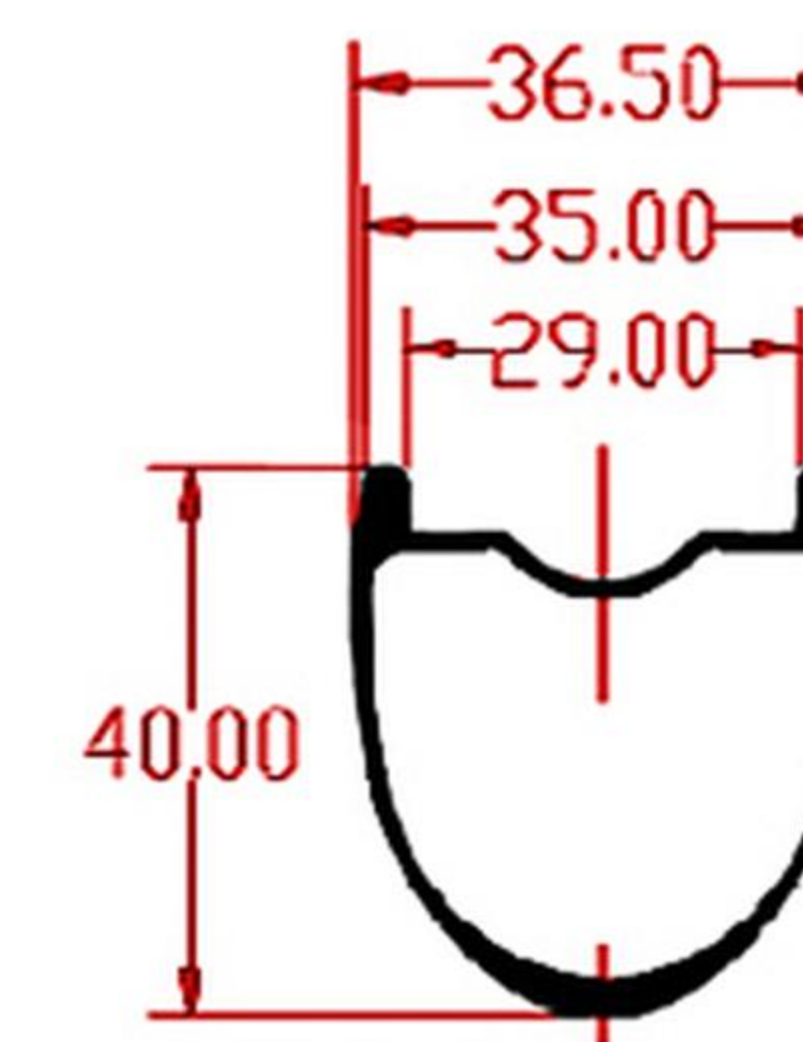

NEW

Model: G40HL-36
Weight: 440±15g(T700)
400±15g(T800)
375±15g(T800 UL)
ERD: 559mm

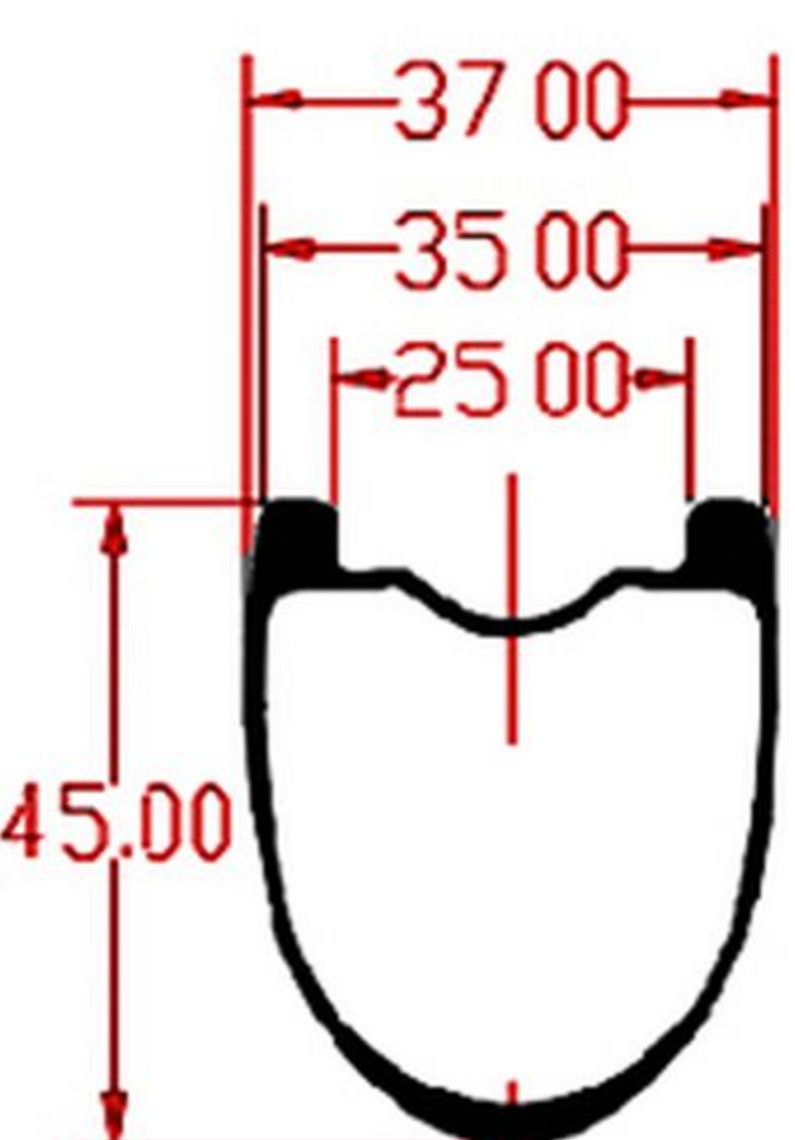

NEW

Model: G45HL-36-TH
Weight: 480±15g(T700)
440±15g(T800)
415±15g(T800 UL)
ERD: 549mm

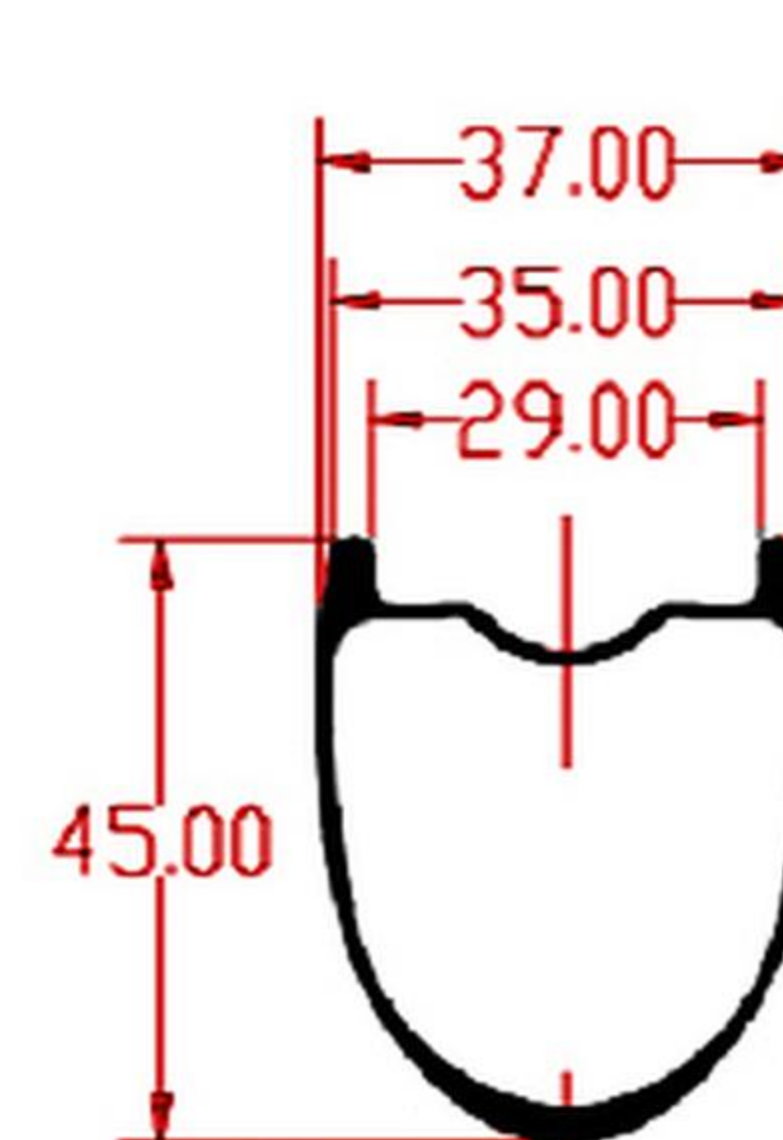

NEW

Model: G45HL-36
Weight: 460±15g(T700)
420±15g(T800)
395±15g(T800 UL)
ERD: 549mm

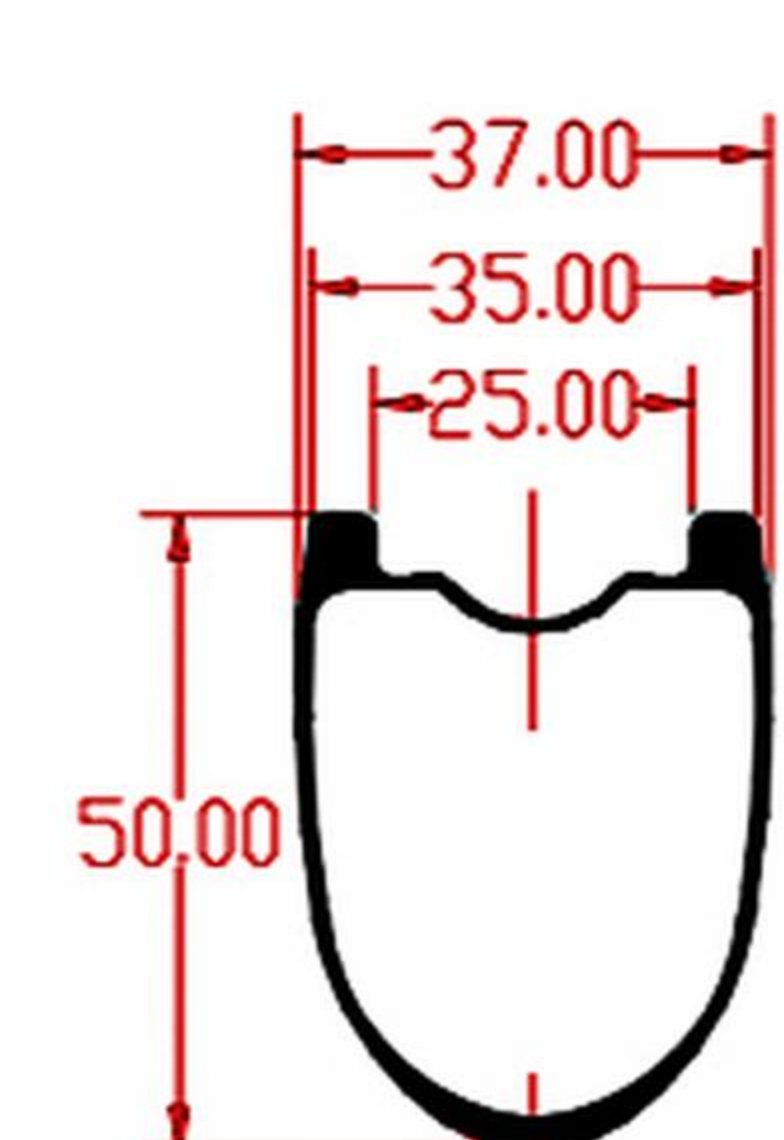

NEW

Model: G50HL-36-TH
Weight: 500±15g(T700)
480±15g(T800)
435±15g(T800 UL)
ERD: 539mm

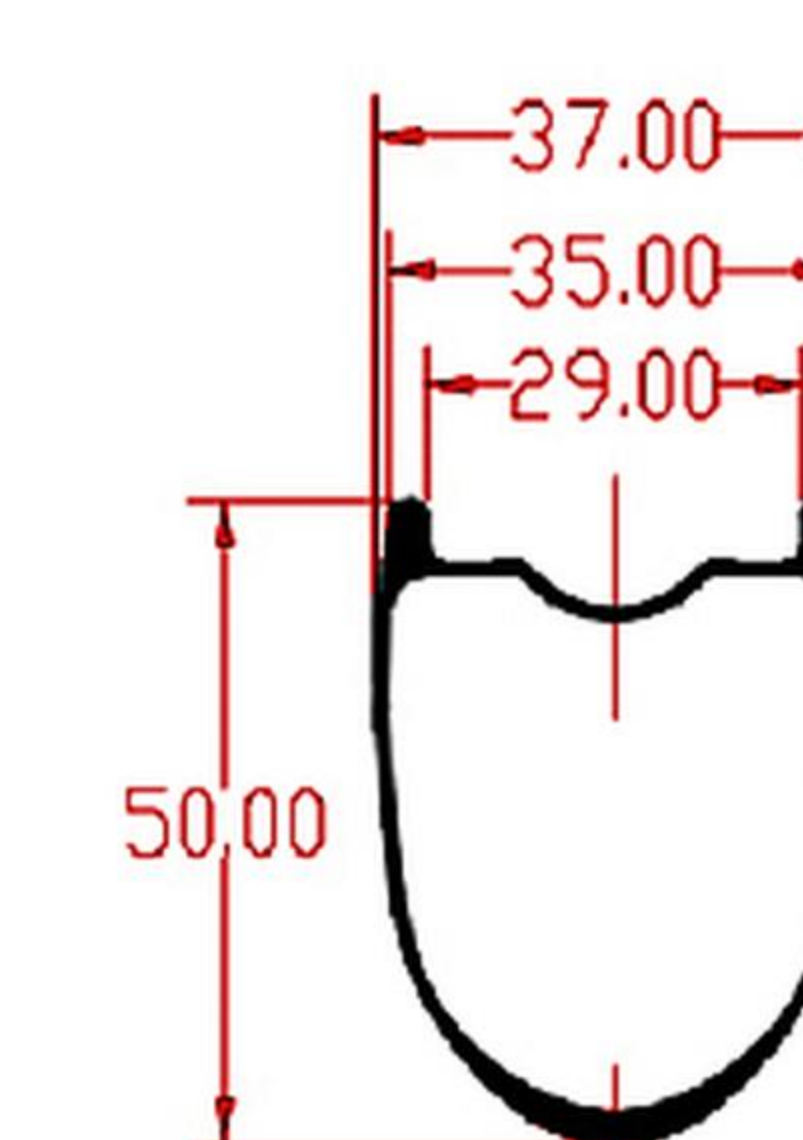

NEW

Model: G50HL-36
Weight: 480±15g(T700)
440±15g(T800)
415±15g(T800 UL)
ERD: 539mm

▶ 29ER/650B Gravel MTB Rims

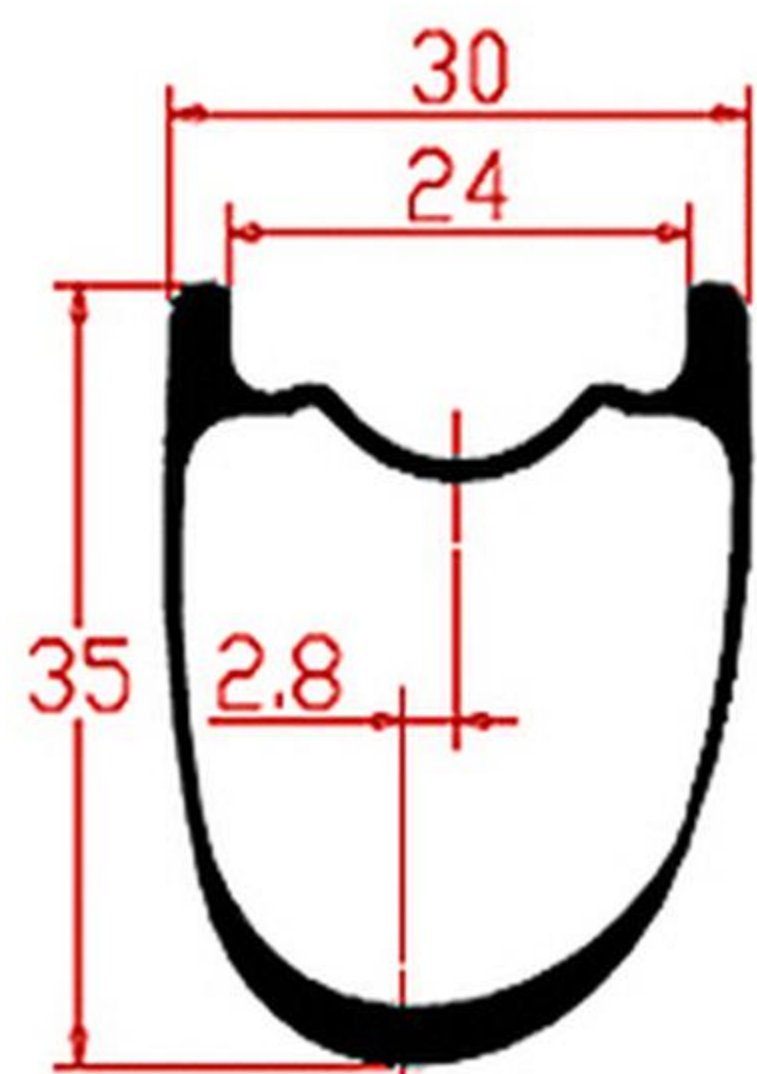

Model: G35HL-30-29ER
Weight: T700: 410±15g
T800: 370±15g
ERD: 569

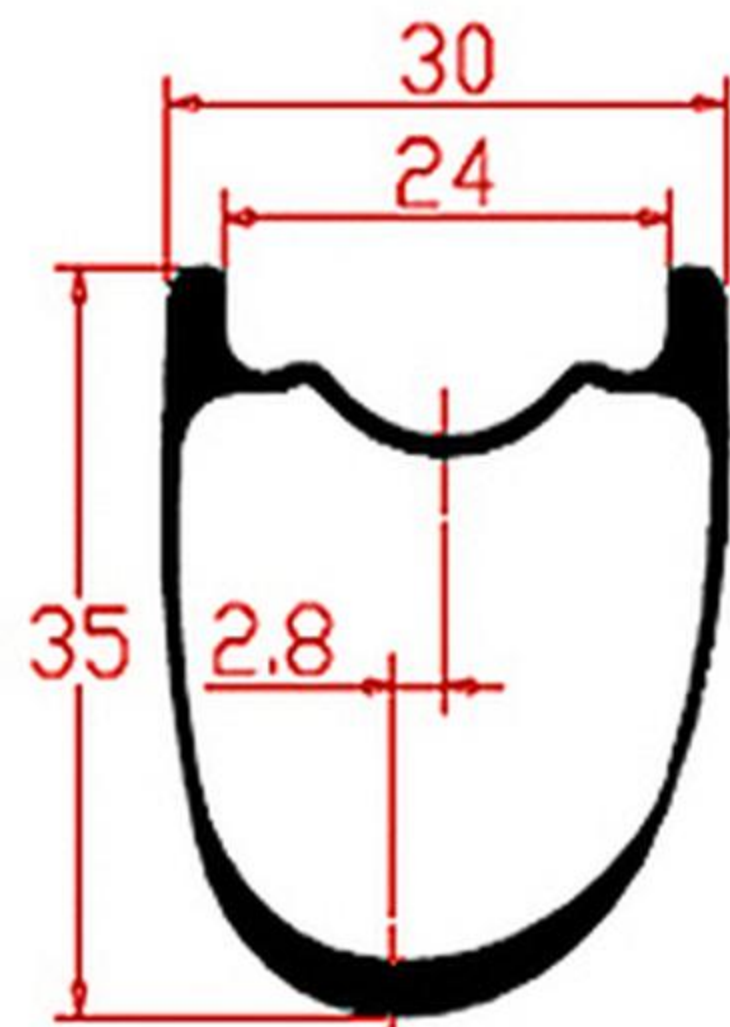

Model: G35HL-30-650B
Weight: T700: 390±15g
T800: 350±15g
ERD: 531

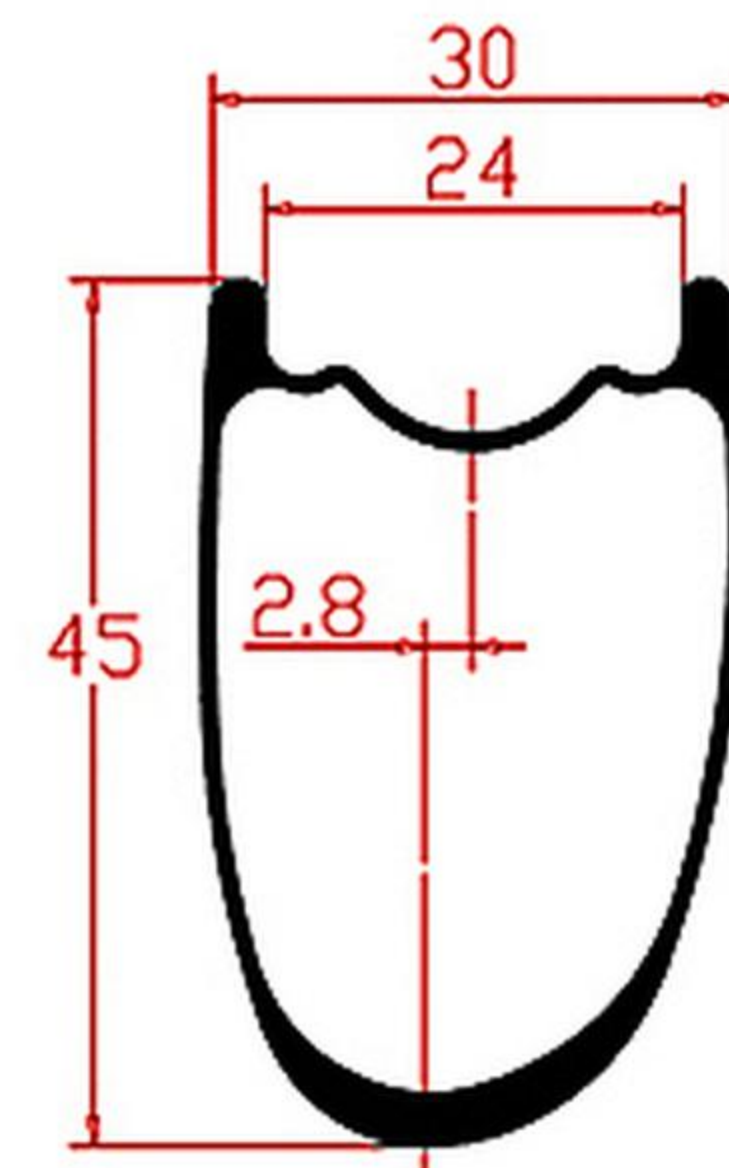

Model: G45HL-30-29ER
Weight: T700: 440±15g
T800: 400±15g
ERD: 549

► Carbon MTB Rims Super Light Series

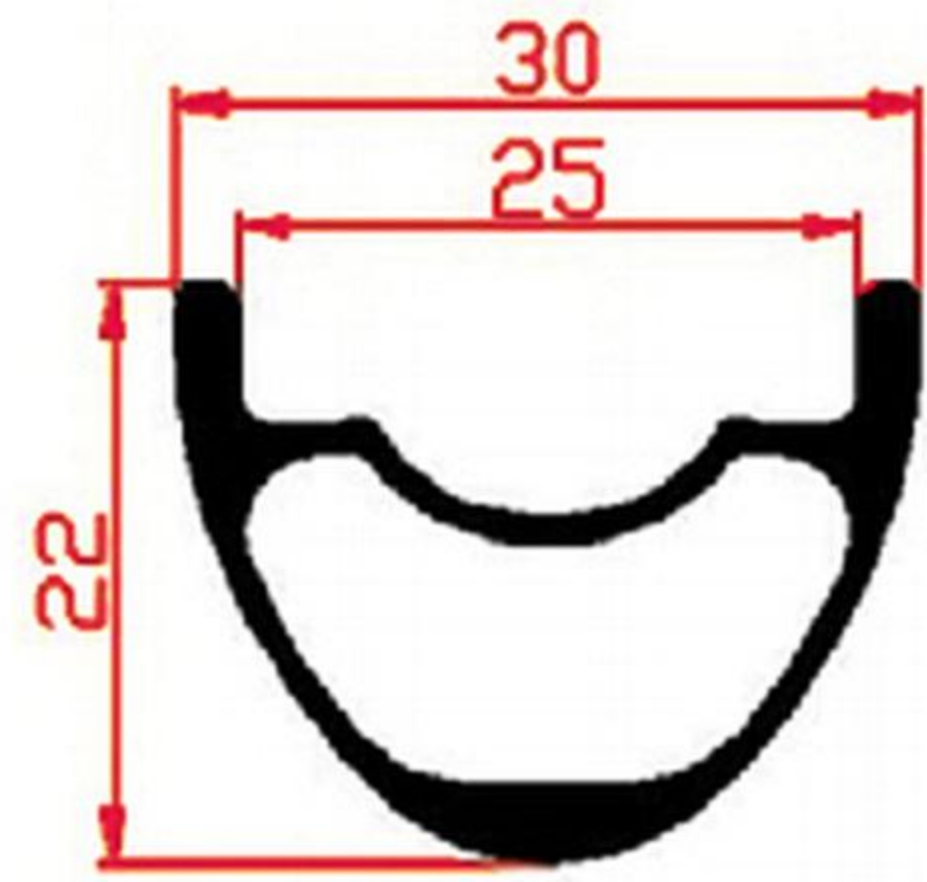

NEW

Model: M2230HL-29ER
Weight: T800:255±10g
ERD: 595

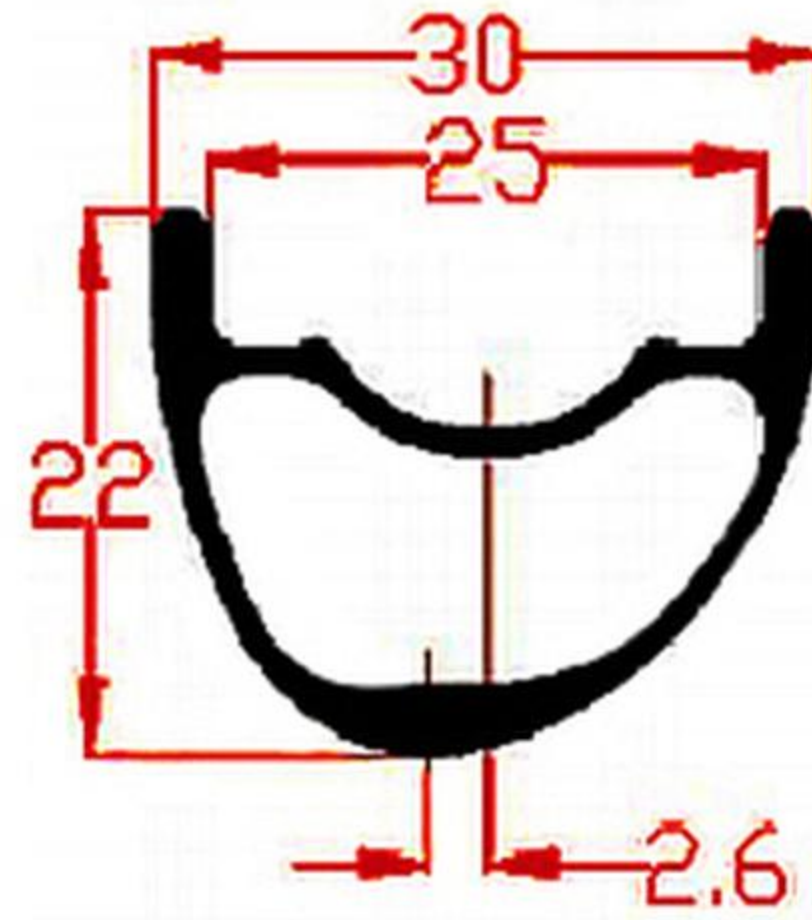

NEW

Model: M2230HL-29ER-ASY
Weight: T800:255±10g
ERD: 595

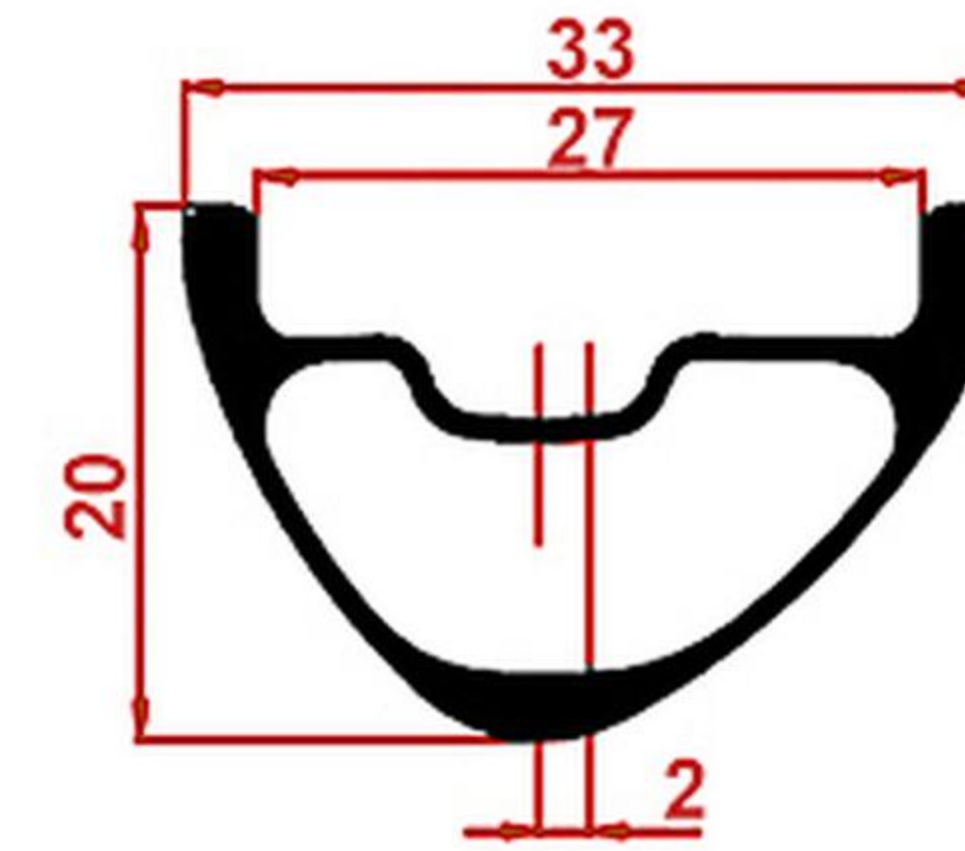

Model: M2033HL-29ER
Weight: XC: 265±15g
AM: 285±15g
DH: 340±15g
ERD: 599

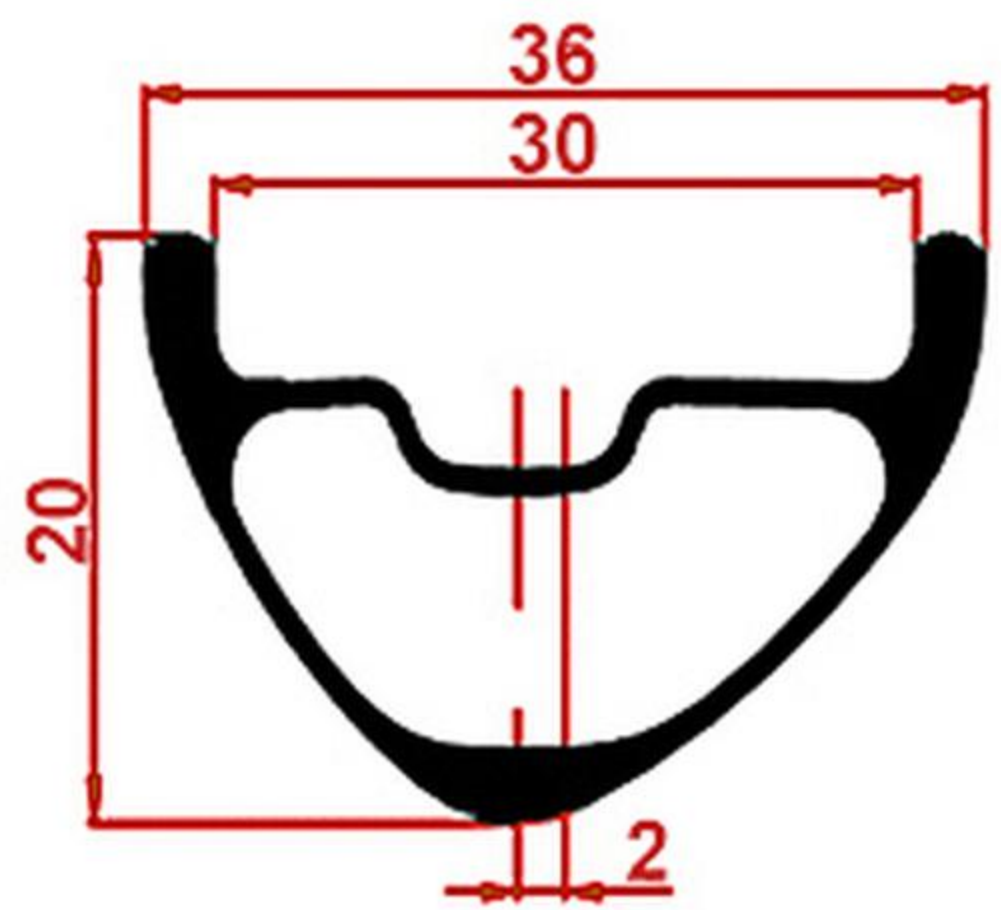

Model: M2036HL-29ER
Weight: XC: 285±15g
AM: 305±15g
DH: 360±15g
ERD: 569

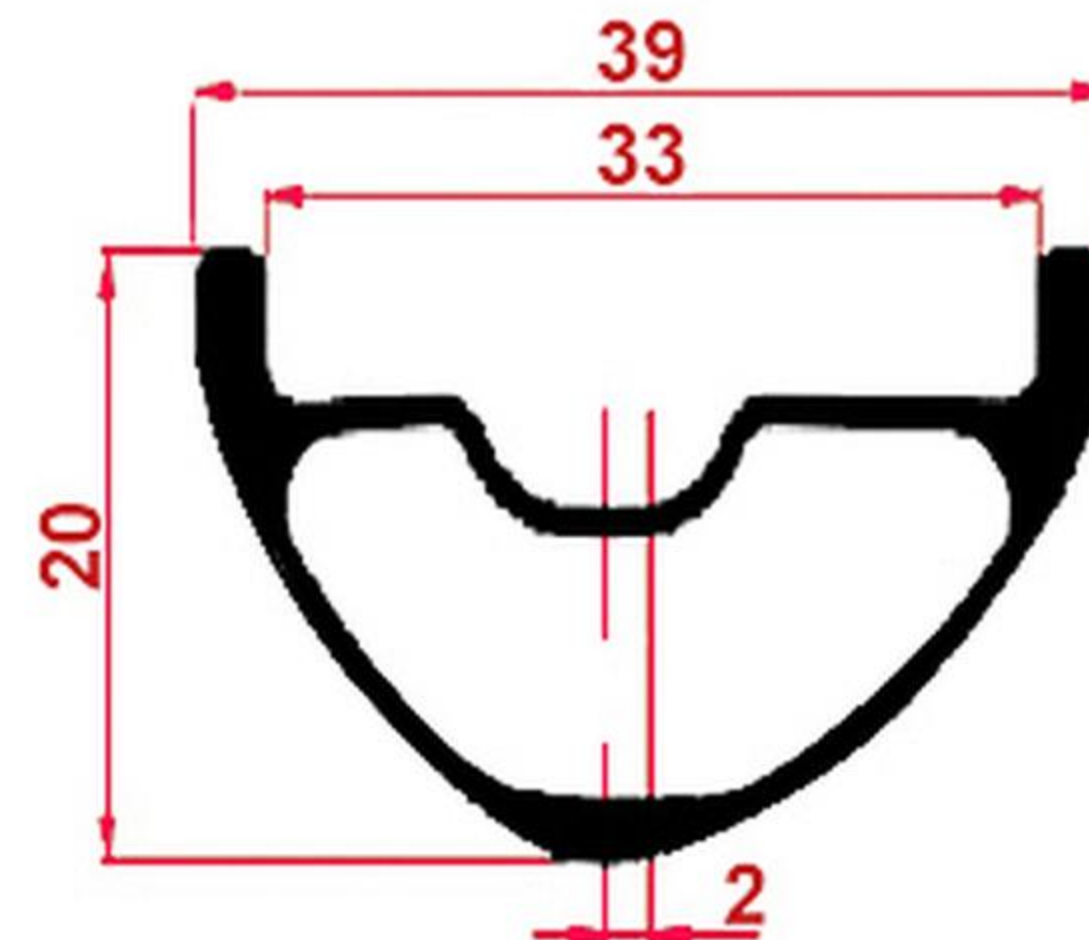

Model: M2039HL-29ER
Weight: XC: 305±10g
AM: 325±15g
DH: 380±15g
ERD: 599

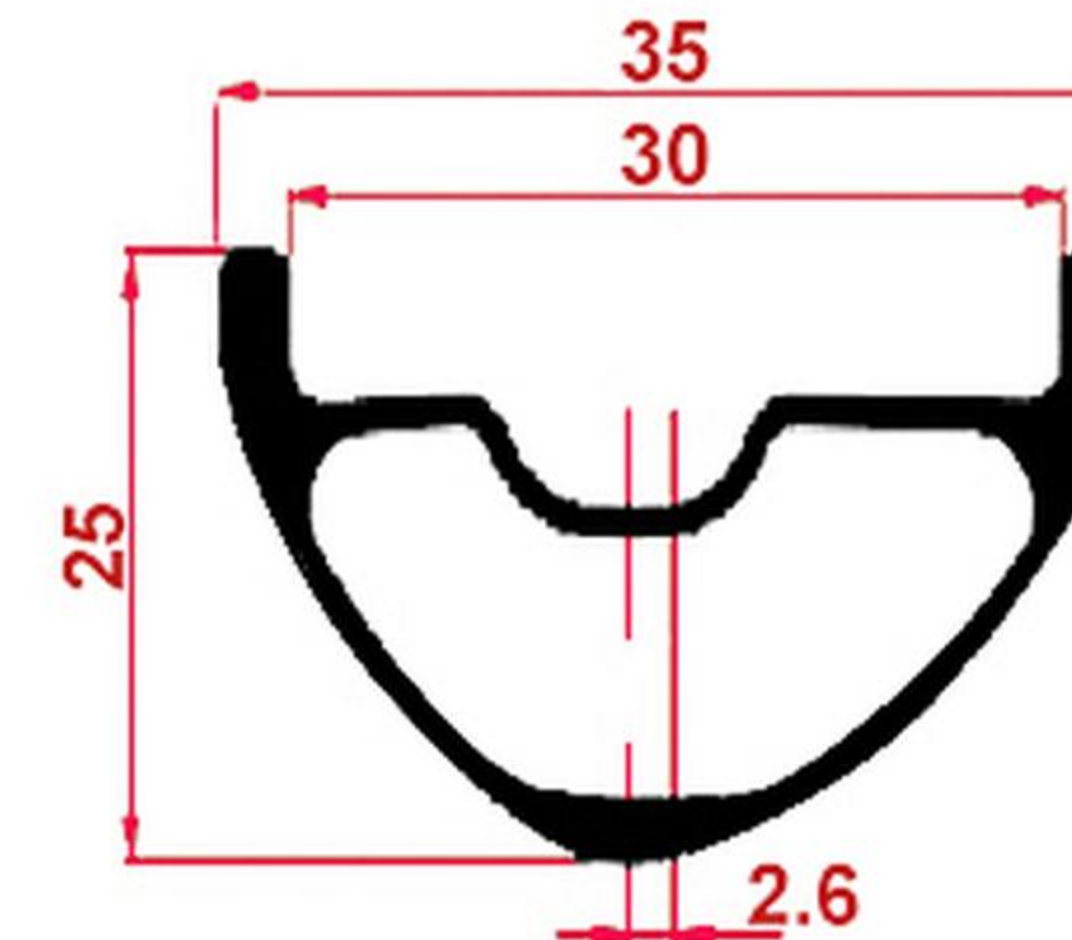

NEW

Model: M2535HL-29ER
Weight: XC: 280±10g
AM: 320±15g
DH: 360±15g
ERD: 589

► Carbon MTB XC/AM Rims Series Symmetric

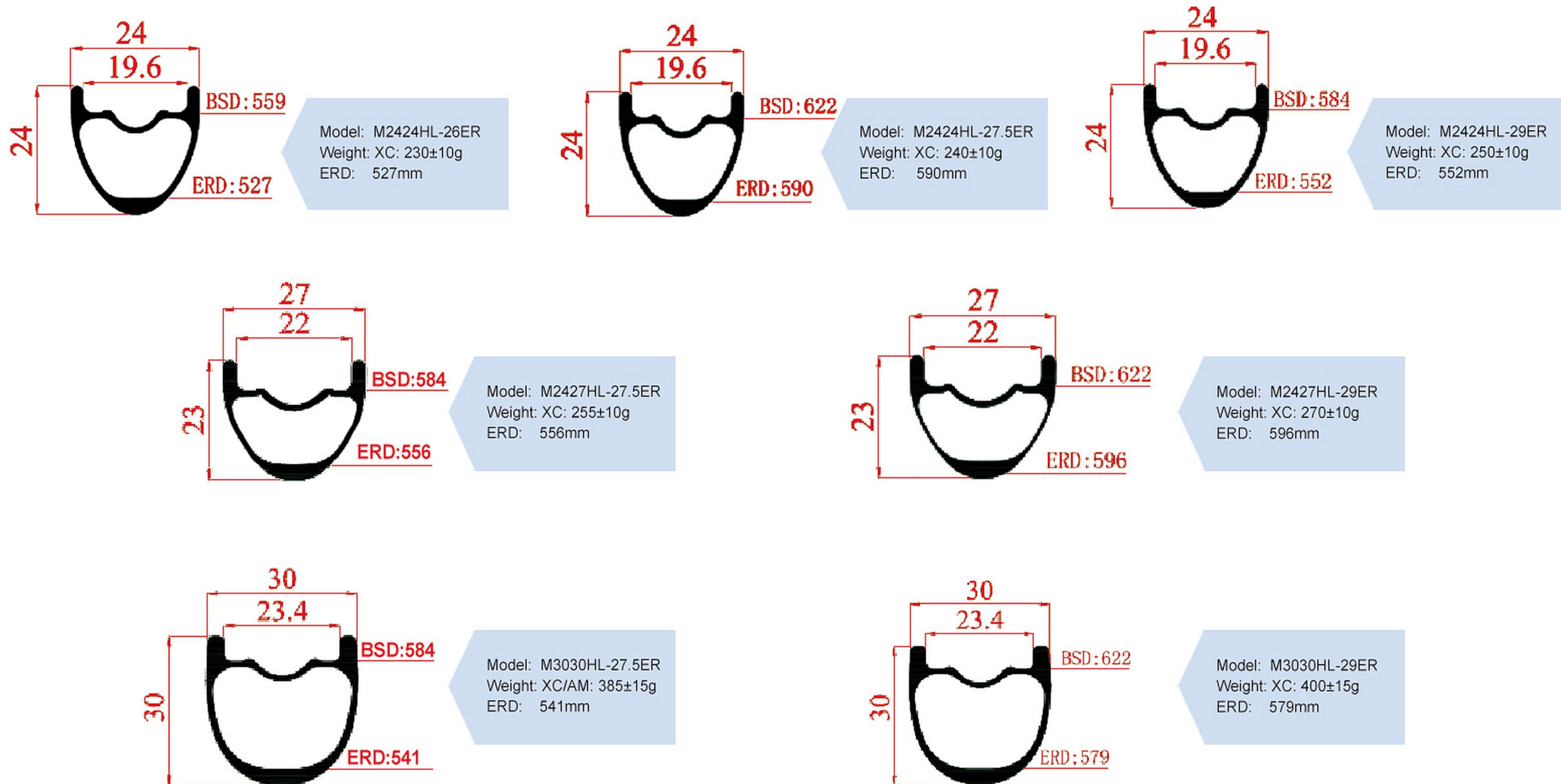

► Carbon MTB XC/AM Rims Series Symmetric

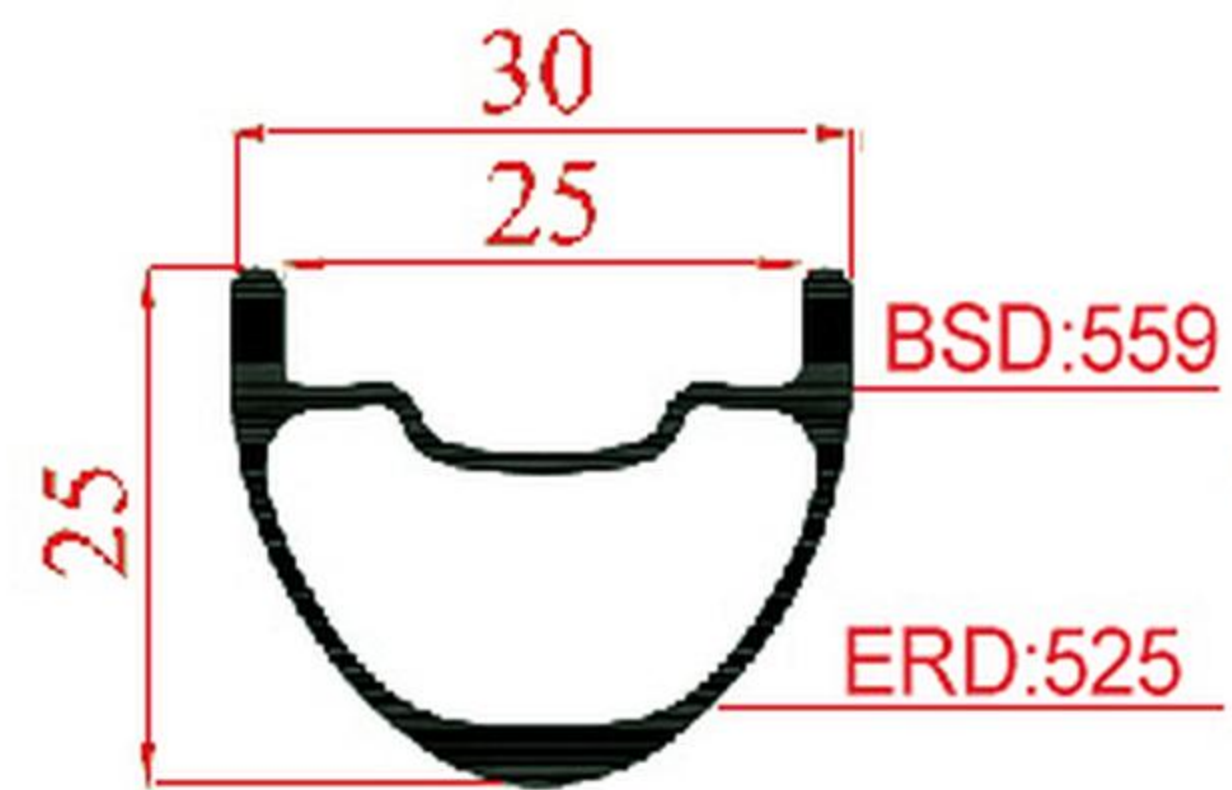

Model: M2530HL-26ER
Weight: XC: 280±10g
ERD: 525mm

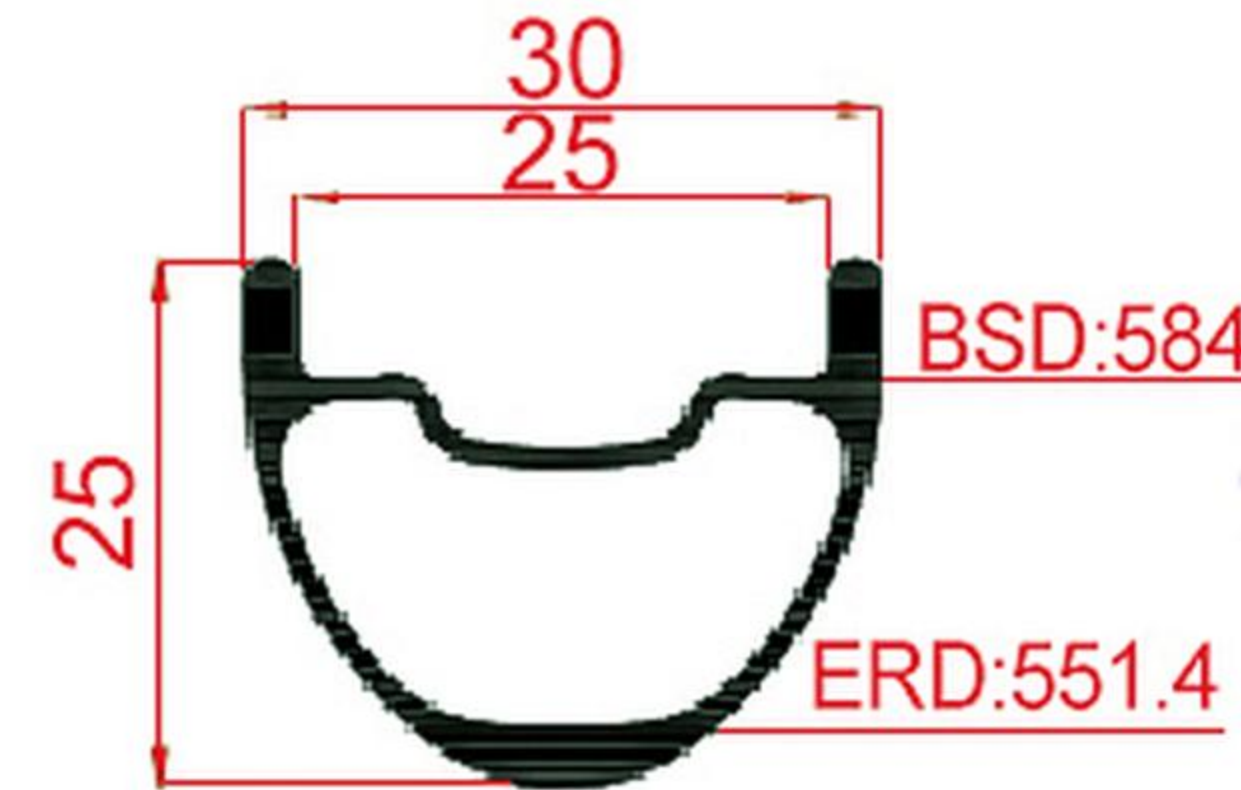

Model: M2424HL-27.5ER
Weight: XC: 295±10g
ERD: 551.4mm

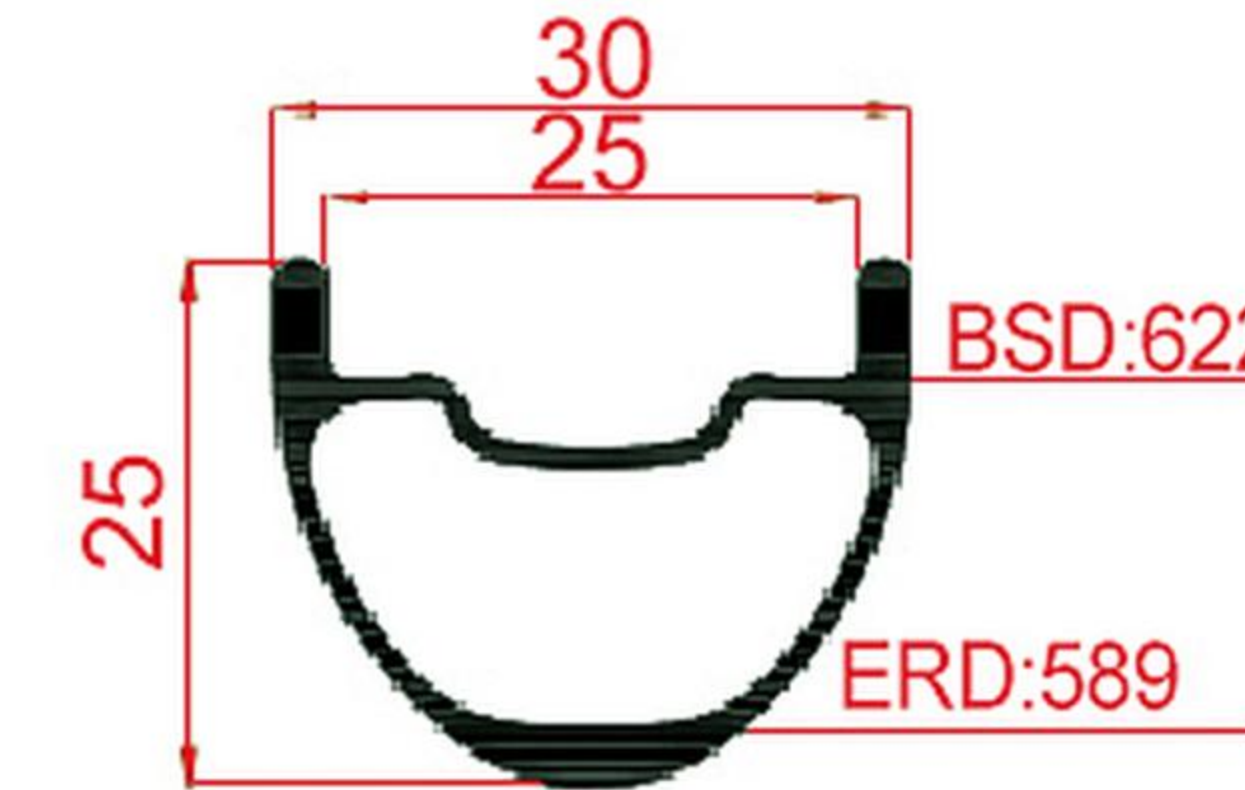

Model: M2424HL-29ER
Weight: XC: 310±10g
ERD: 589mm

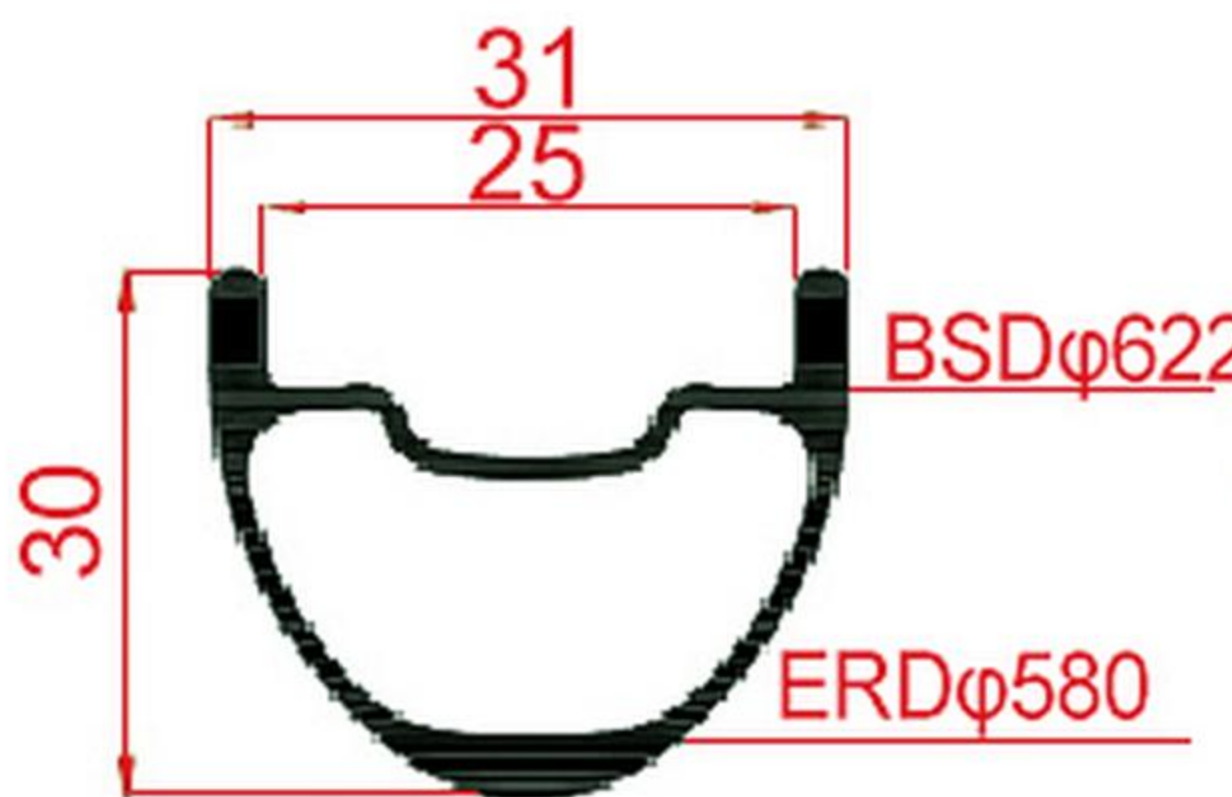

Model: M3031HL-29ER
Weight: XC: 340±10g
ERD: 580mm

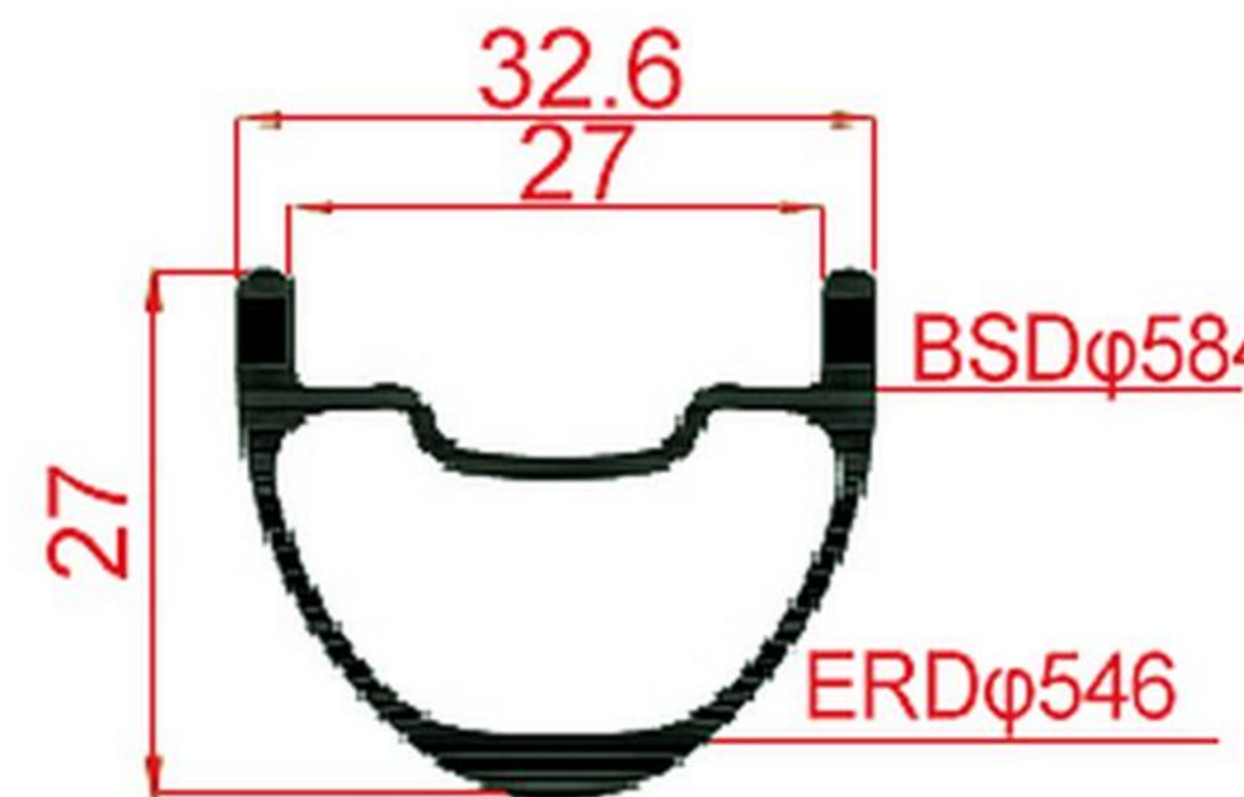

Model: M2732HL-27.5ER
Weight: XC: 350±10g
ERD: 546mm

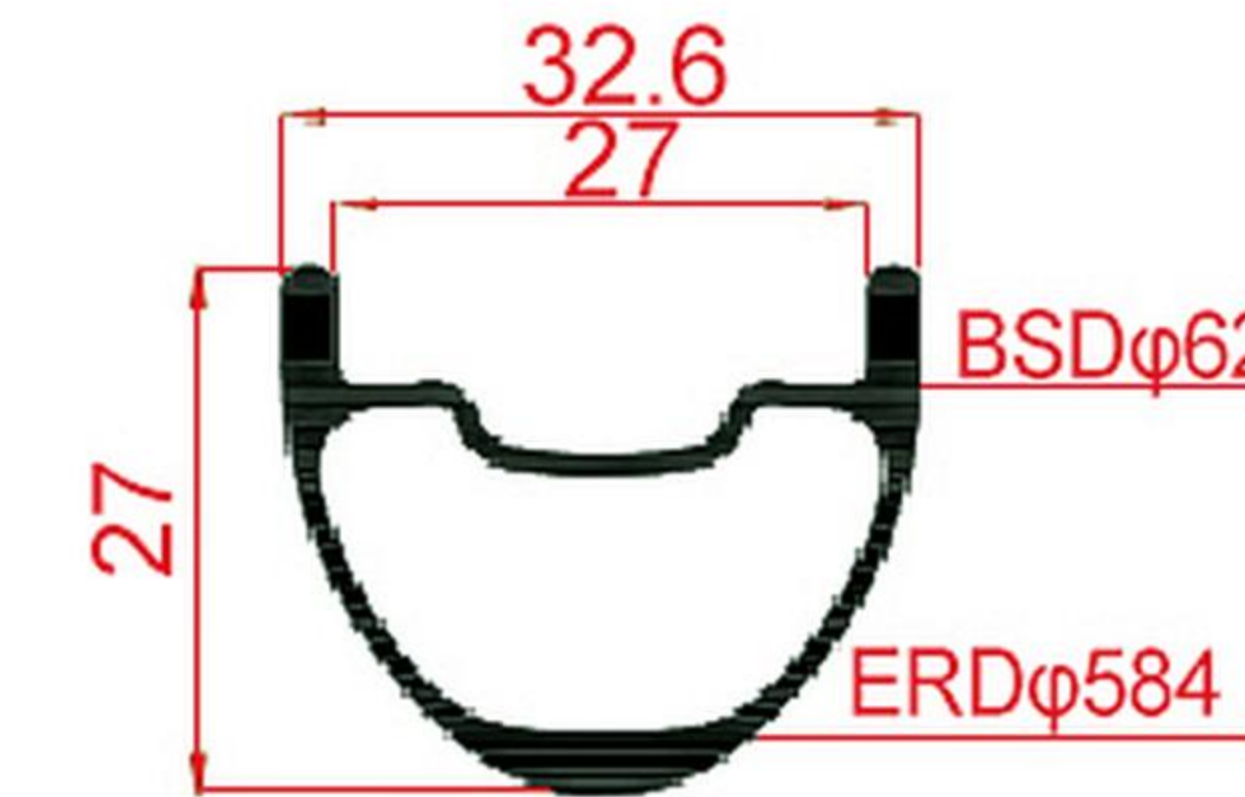

Model: M2732HL-29ER
Weight: XC: 365±10g
ERD: 584mm

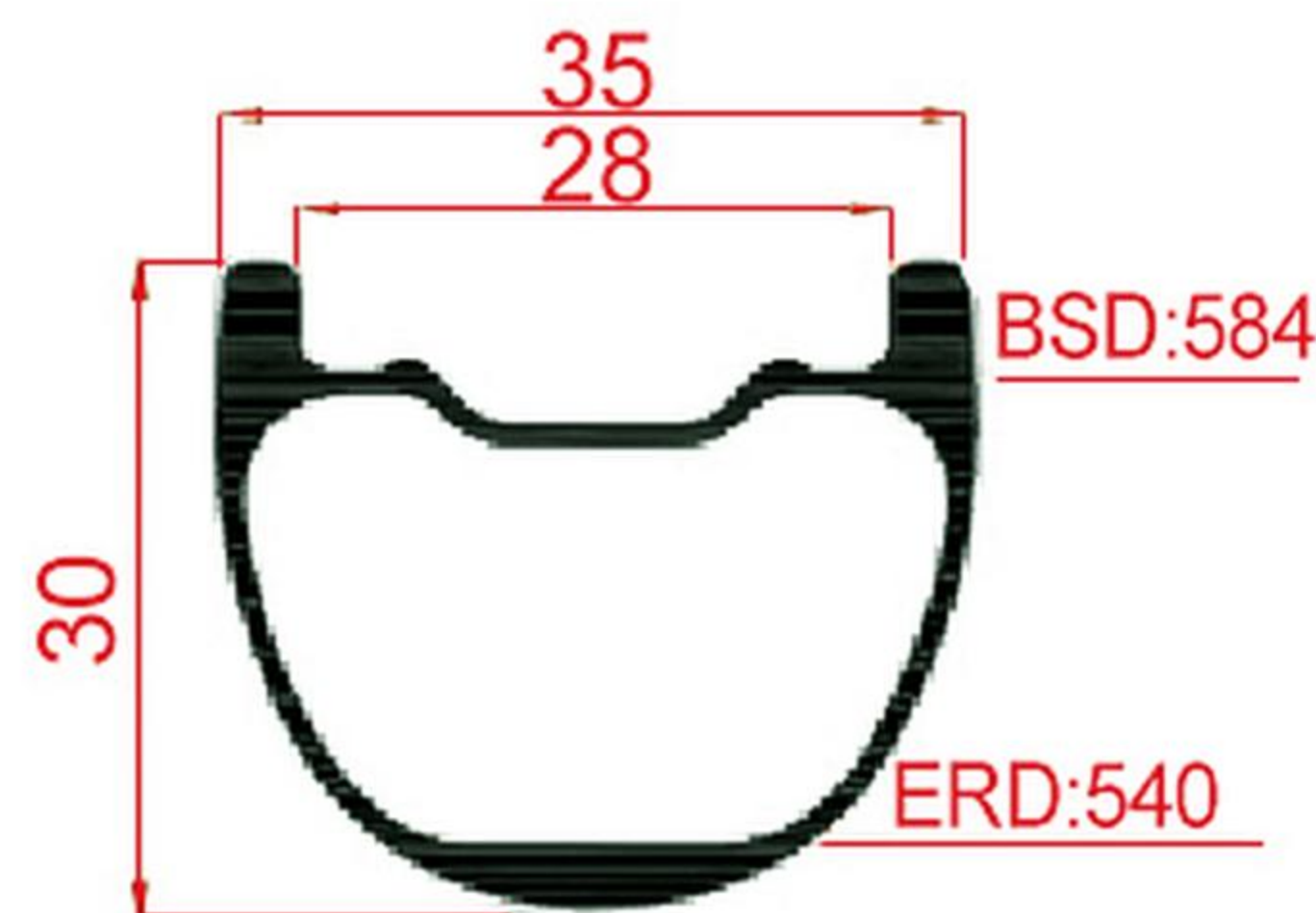

Model: M3035HL-27.5ER
Weight: AM: 445±15g
ERD: 540mm

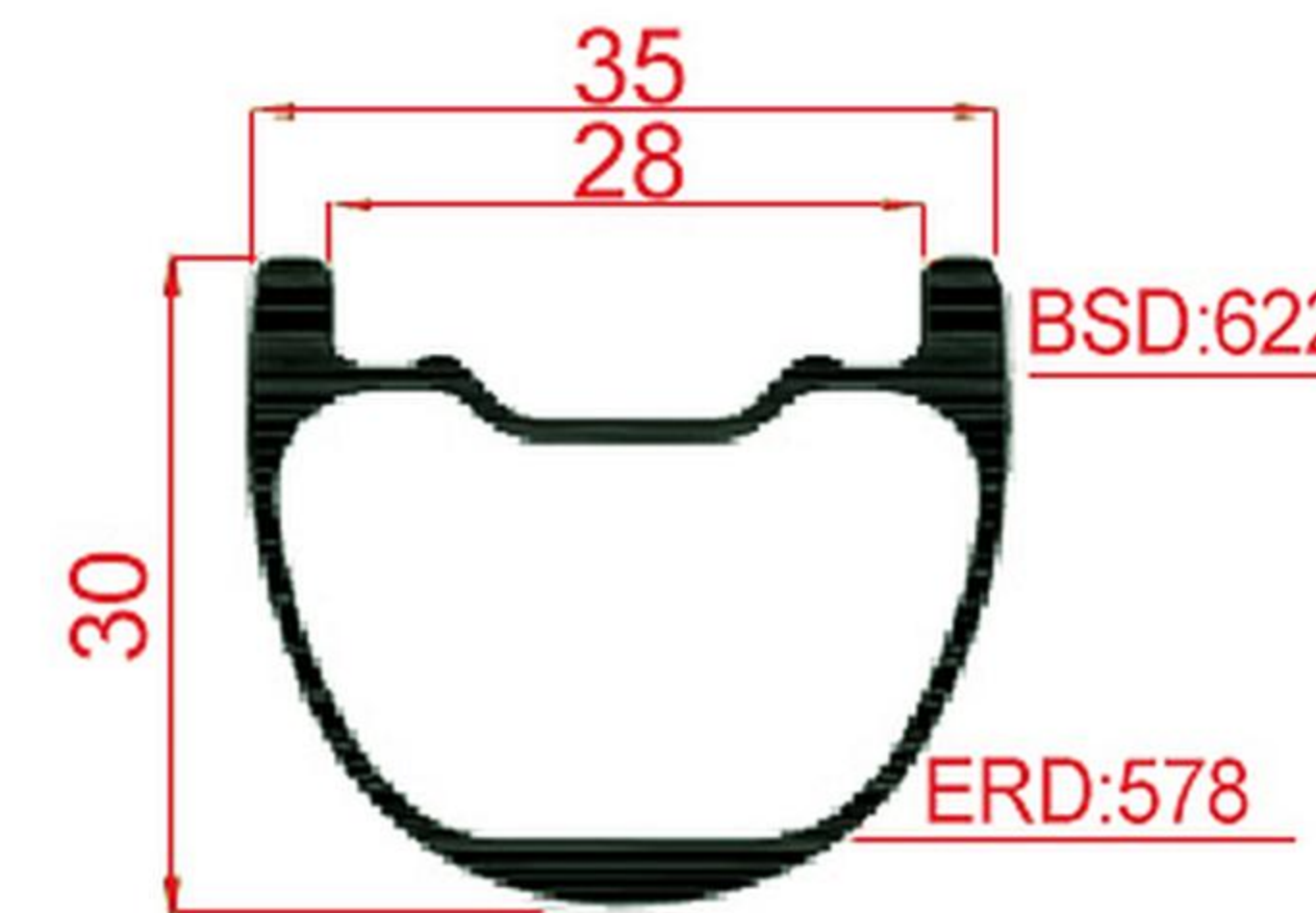

Model: M3035HL-29ER
Weight: AM: 470±15g
ERD: 578mm

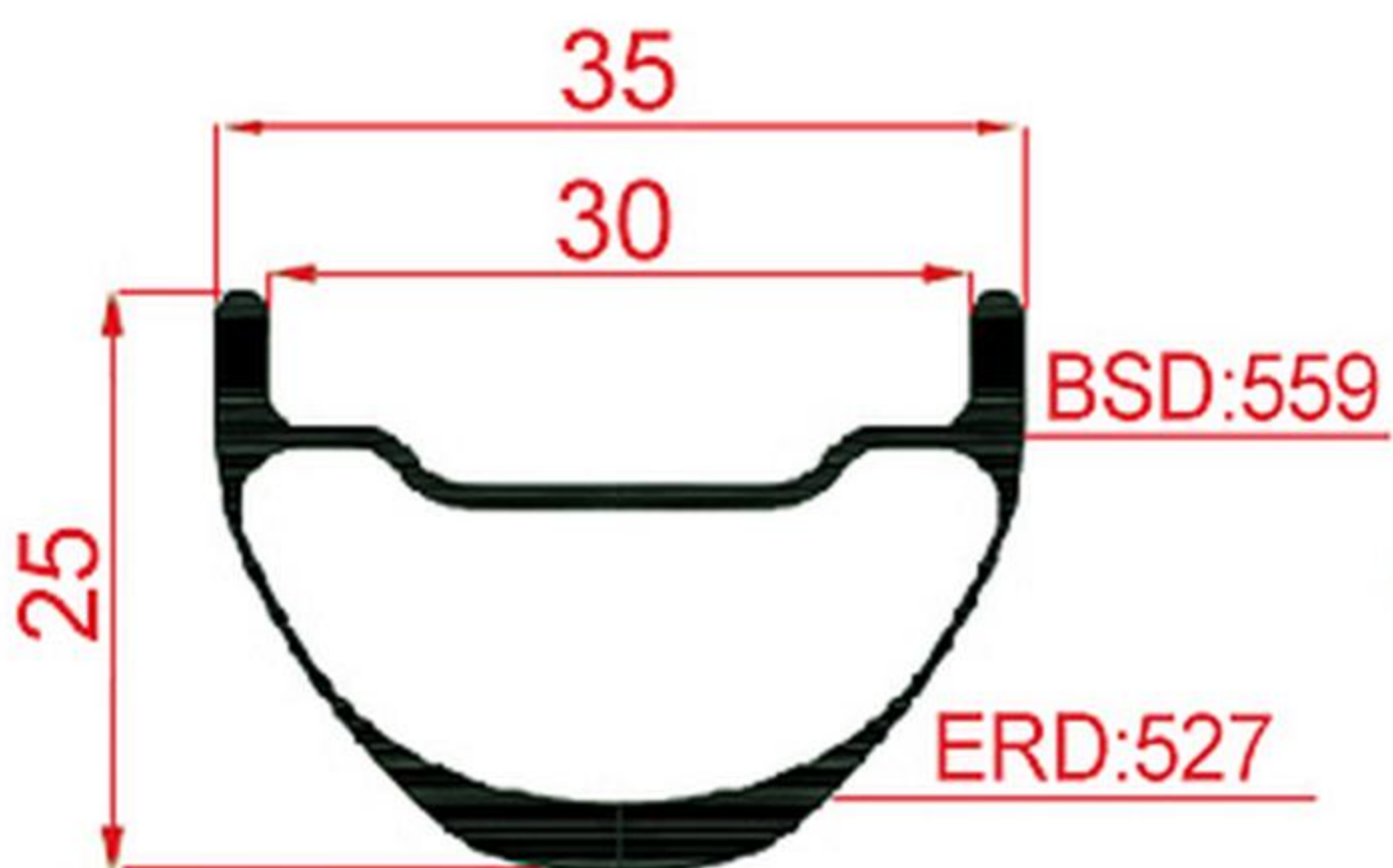

Model: M2535HL-26ER
Weight: XC: 330±10g
ERD: 527mm

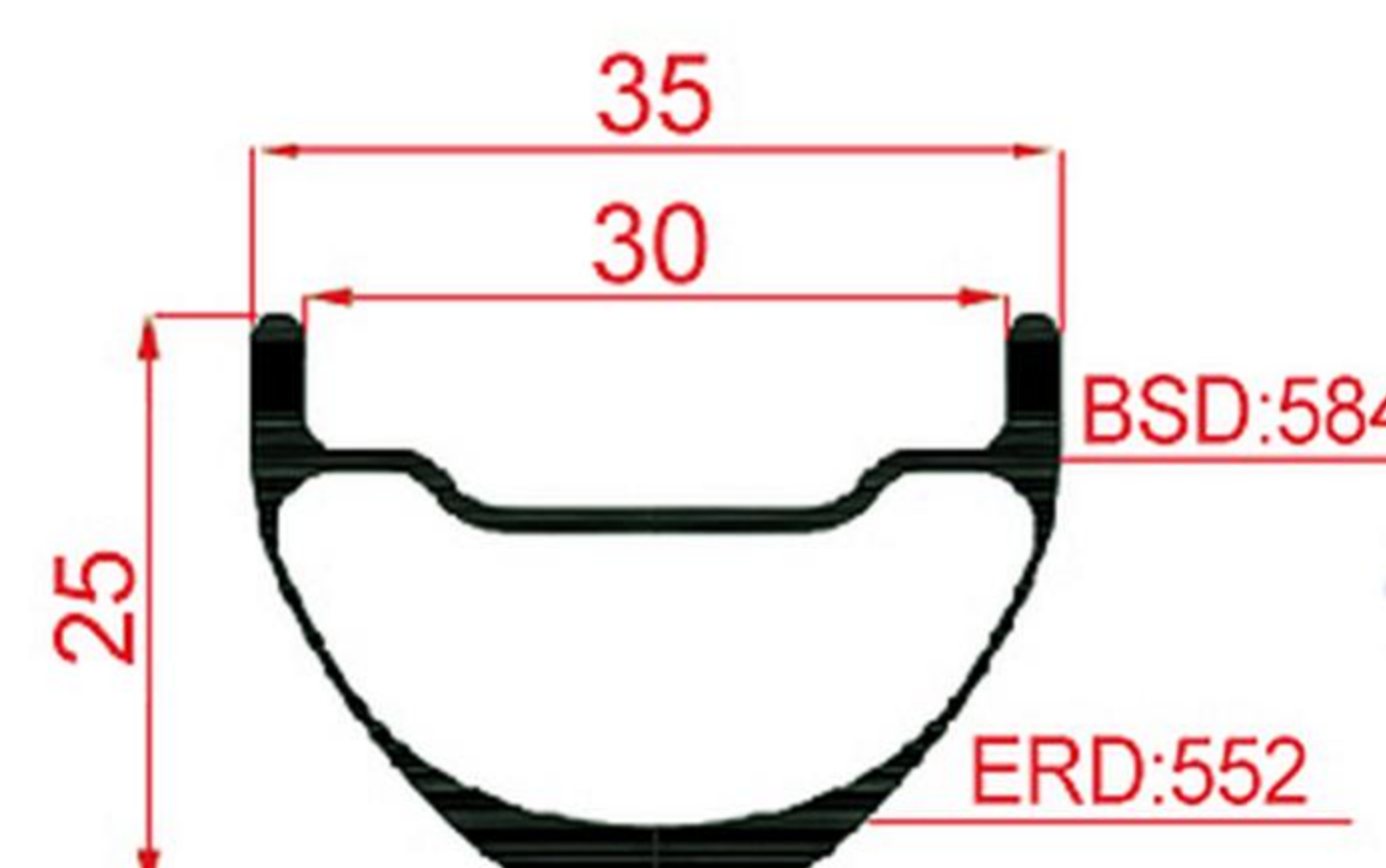

Model: M2535HL-27.5ER
Weight: XC: 345±10g
ERD: 552mm



Model: M2535HL-29ER
Weight: XC: 360±10g
ERD: 590mm

► Carbon MTB XC/AM Rims Series Symmetric

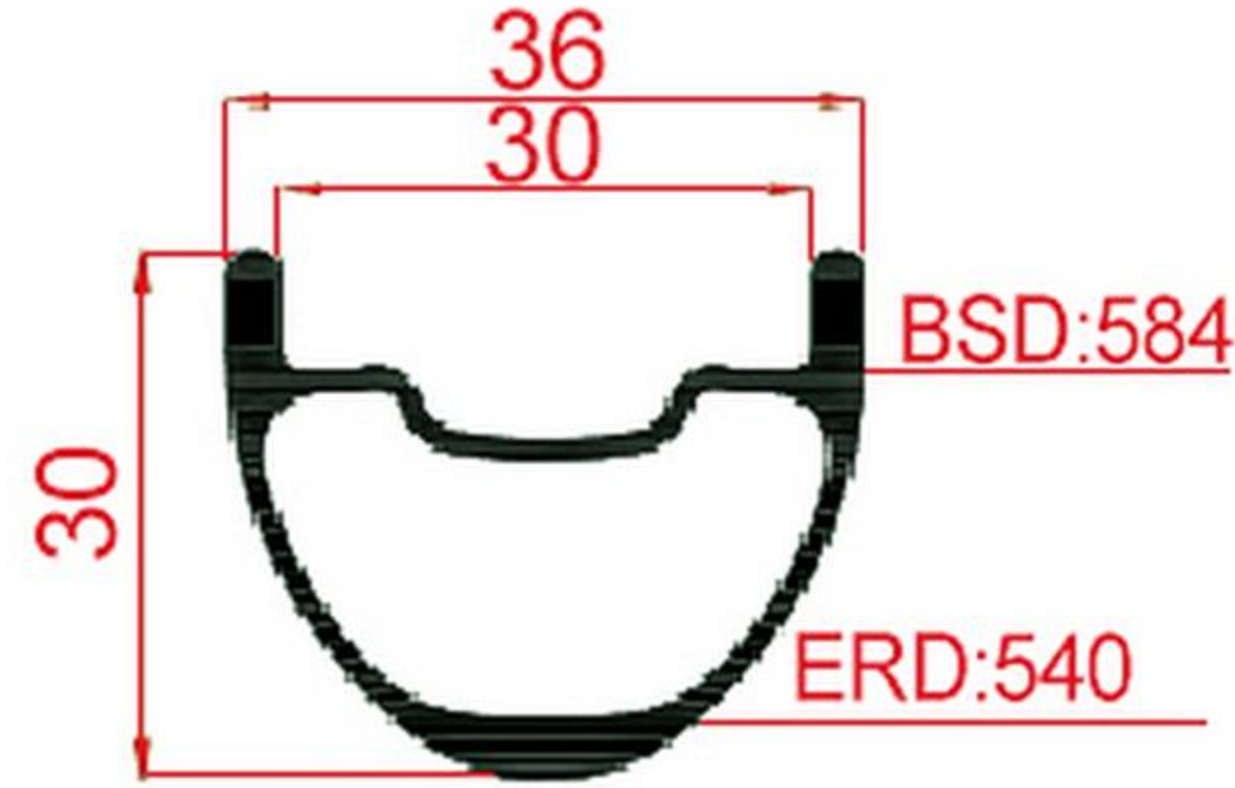

Model: M3036HL-27.5ER
Weight: XC/AM: 375±10g
ERD: 540mm

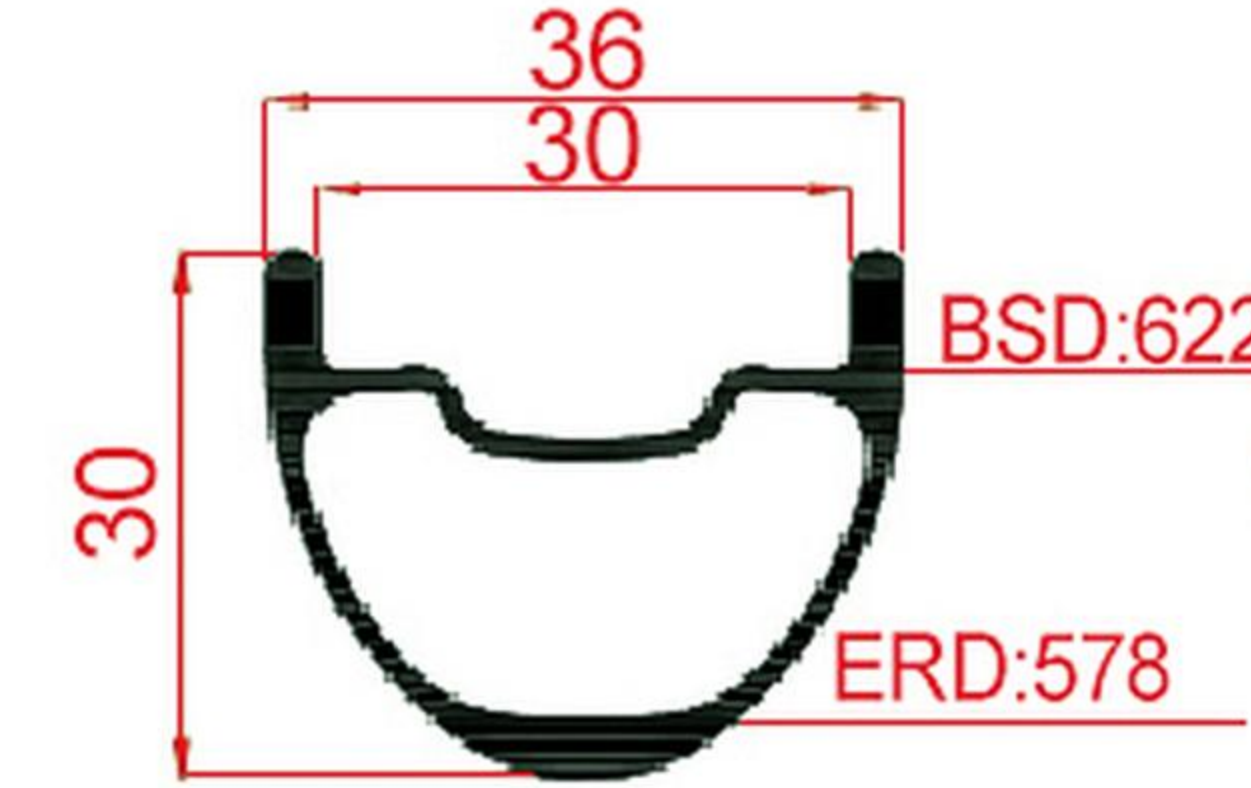

Model: M3036HL-29ER
Weight: XC/AM: 400±10g
ERD: 578mm

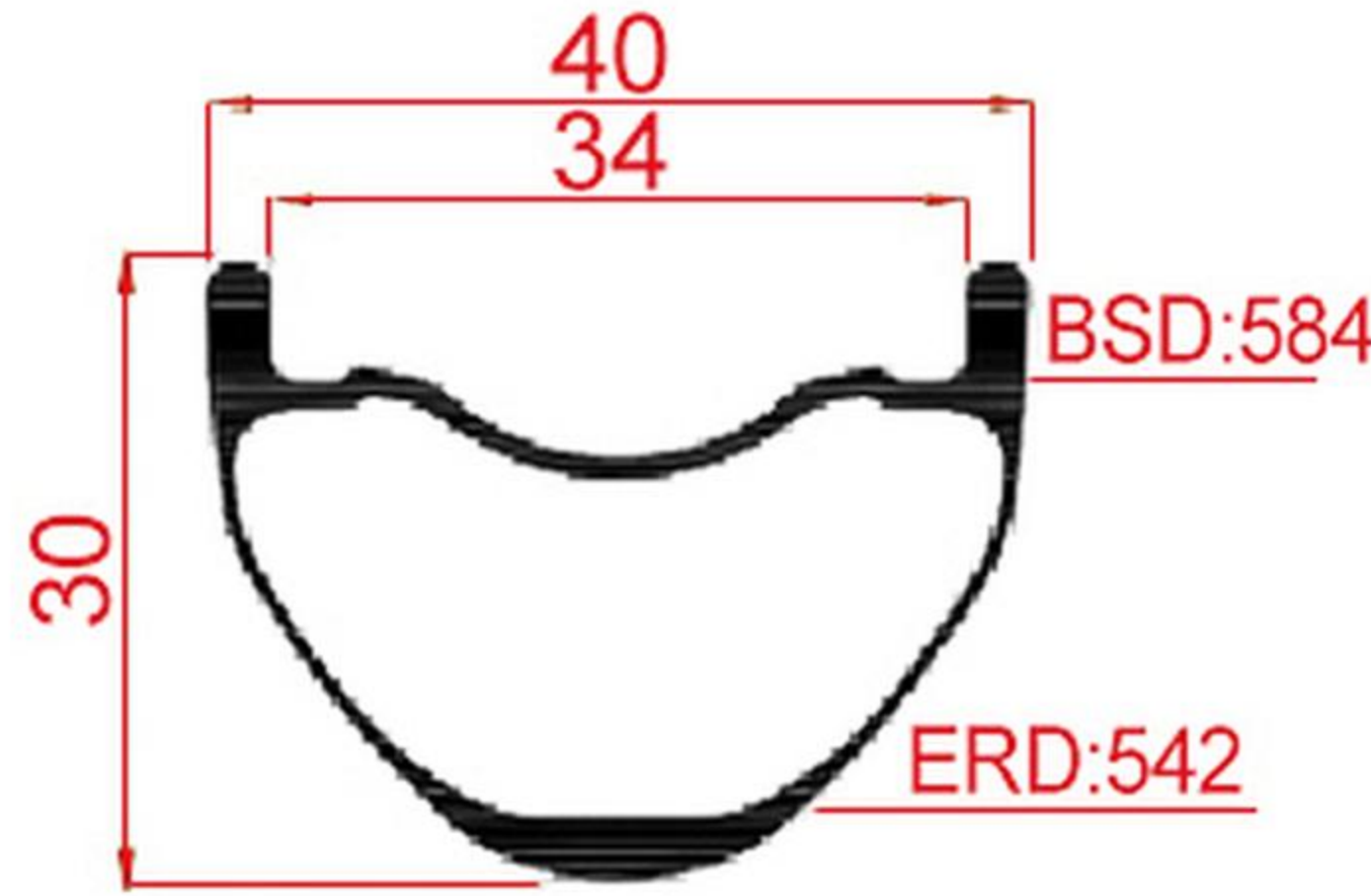

Model: M3040HL-27.5ER
Weight: AM: 390±10g
ERD: 542mm

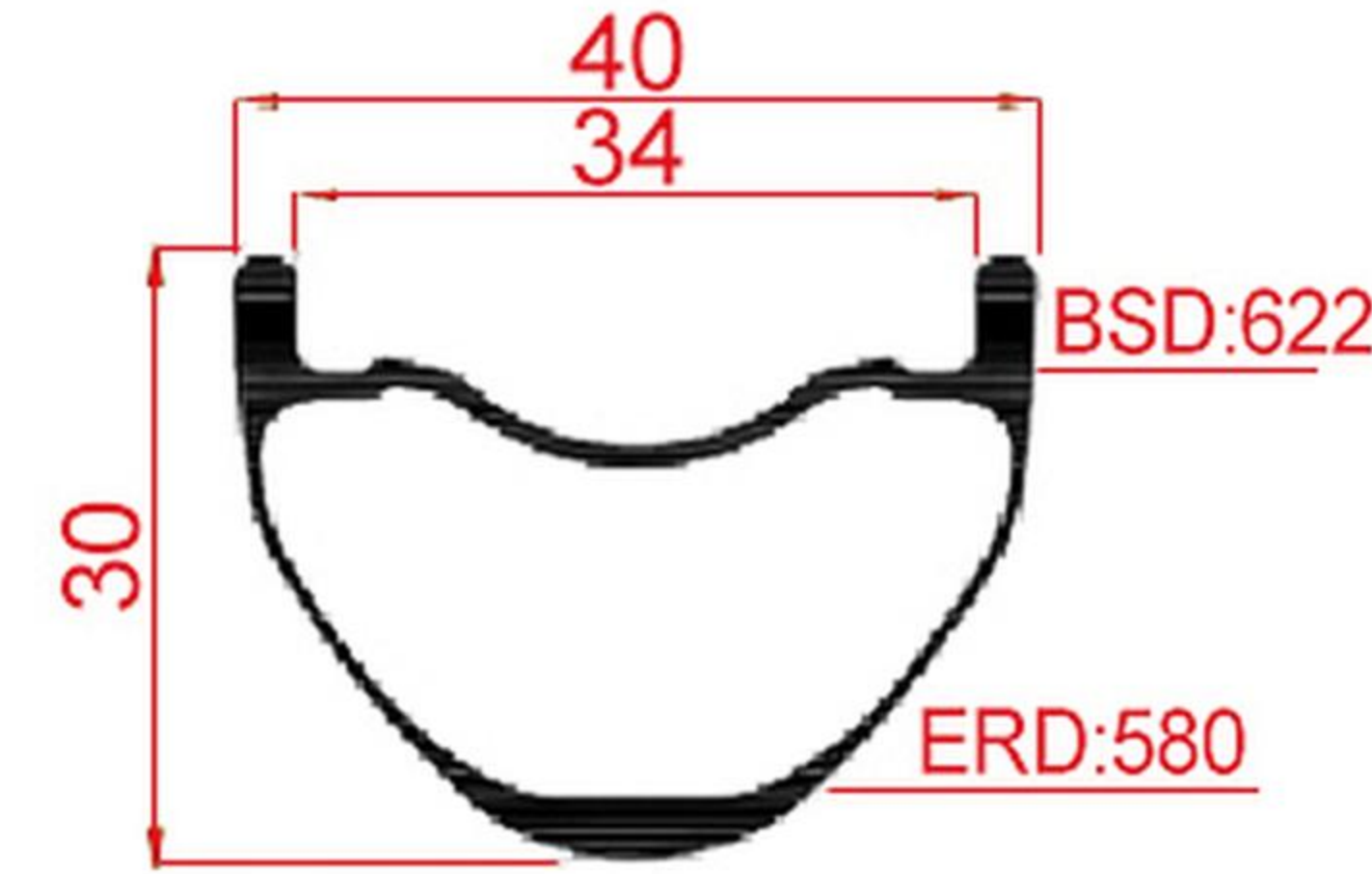

Model: M3040HL-29ER
Weight: AM: 410±10g
ERD: 580mm

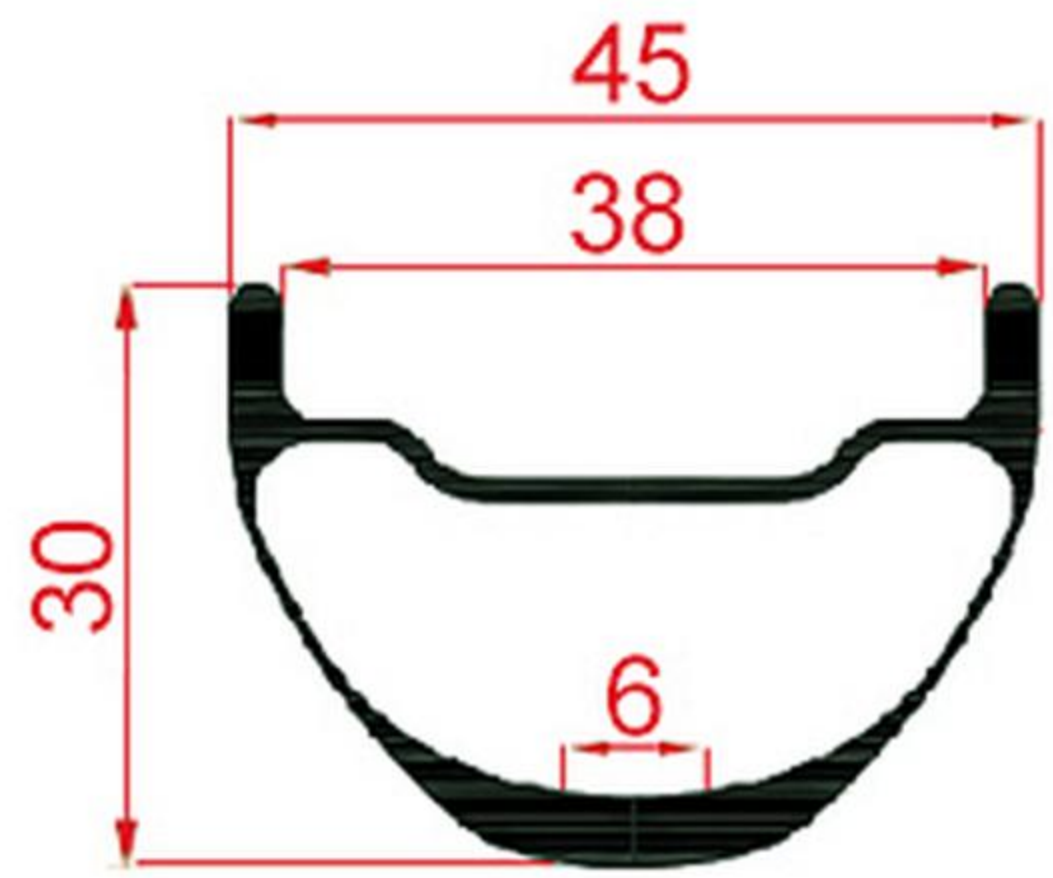

Model: M3045HL-650B
Weight: AM: 490±15g
DH: 550±15g
ERD: 541mm

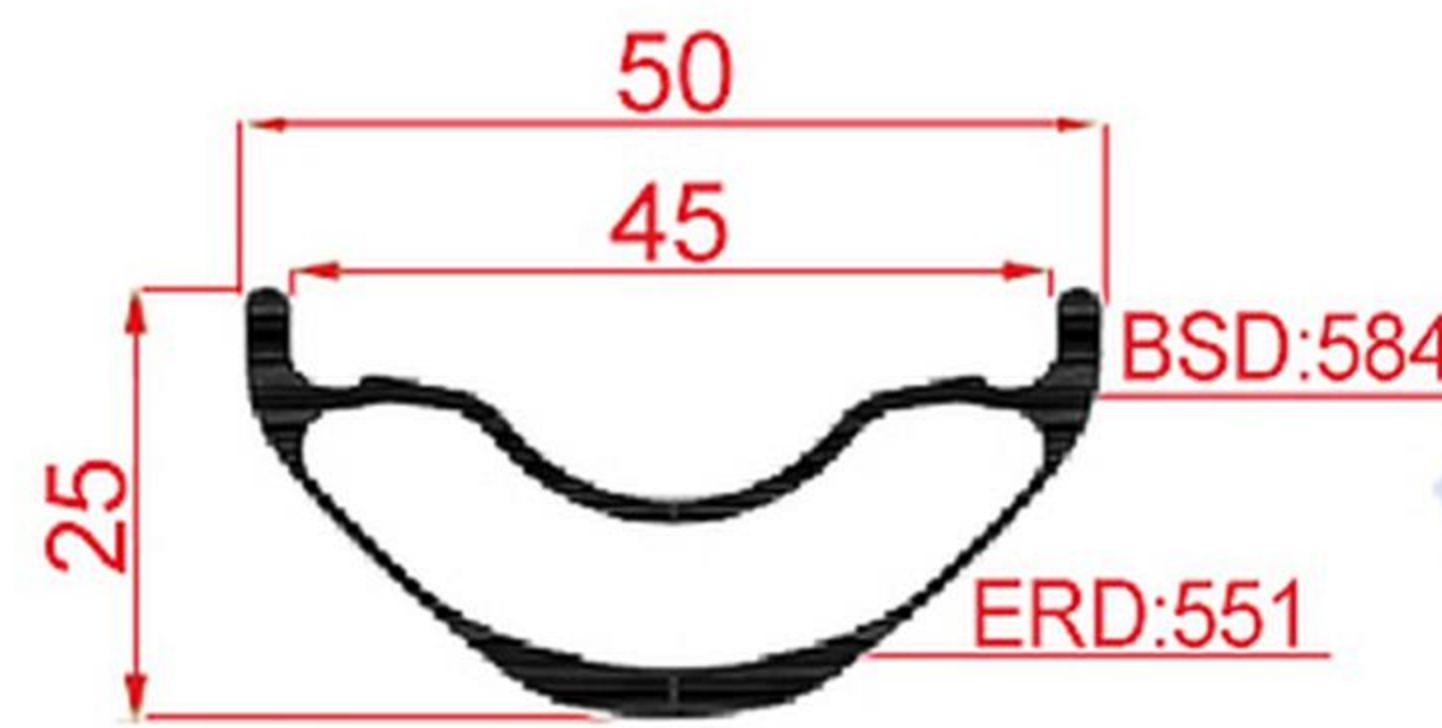

Model: M2550HL-27.5ER
Weight: AM: 500±15g
ERD: 551mm

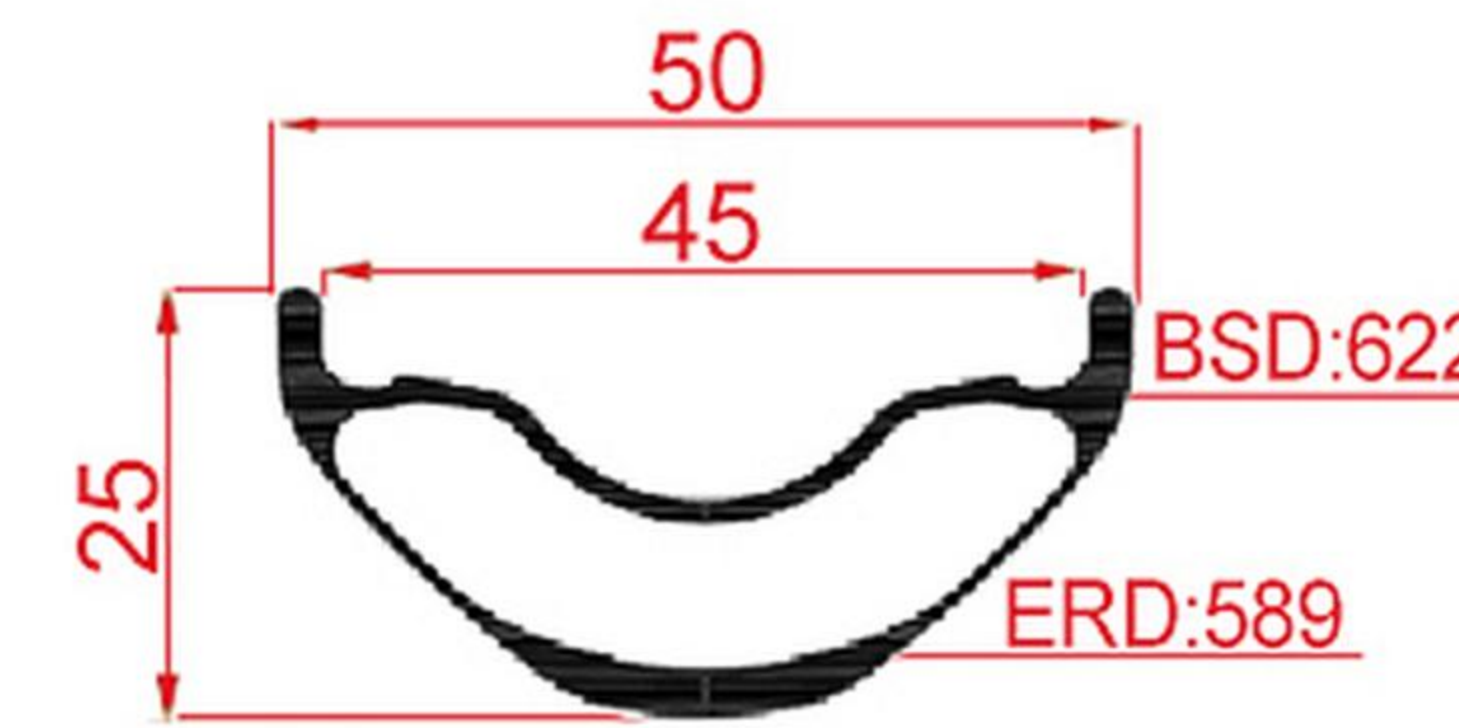

Model: M2550HL-29ER
Weight: AM: 520±15g
ERD: 589mm

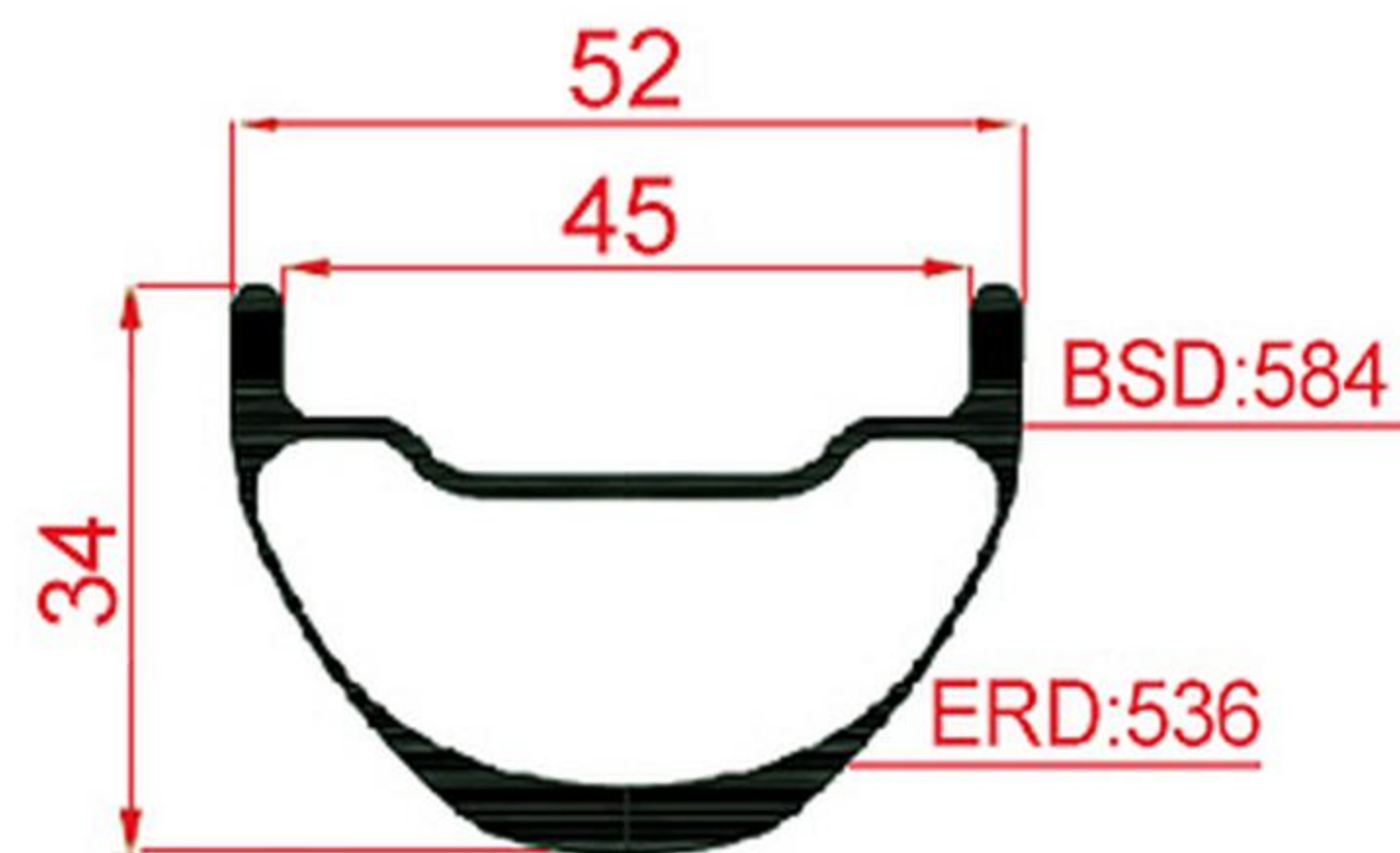

Model: M3452HL-27.5ER
Weight: AM: 540±15g
ERD: 536mm

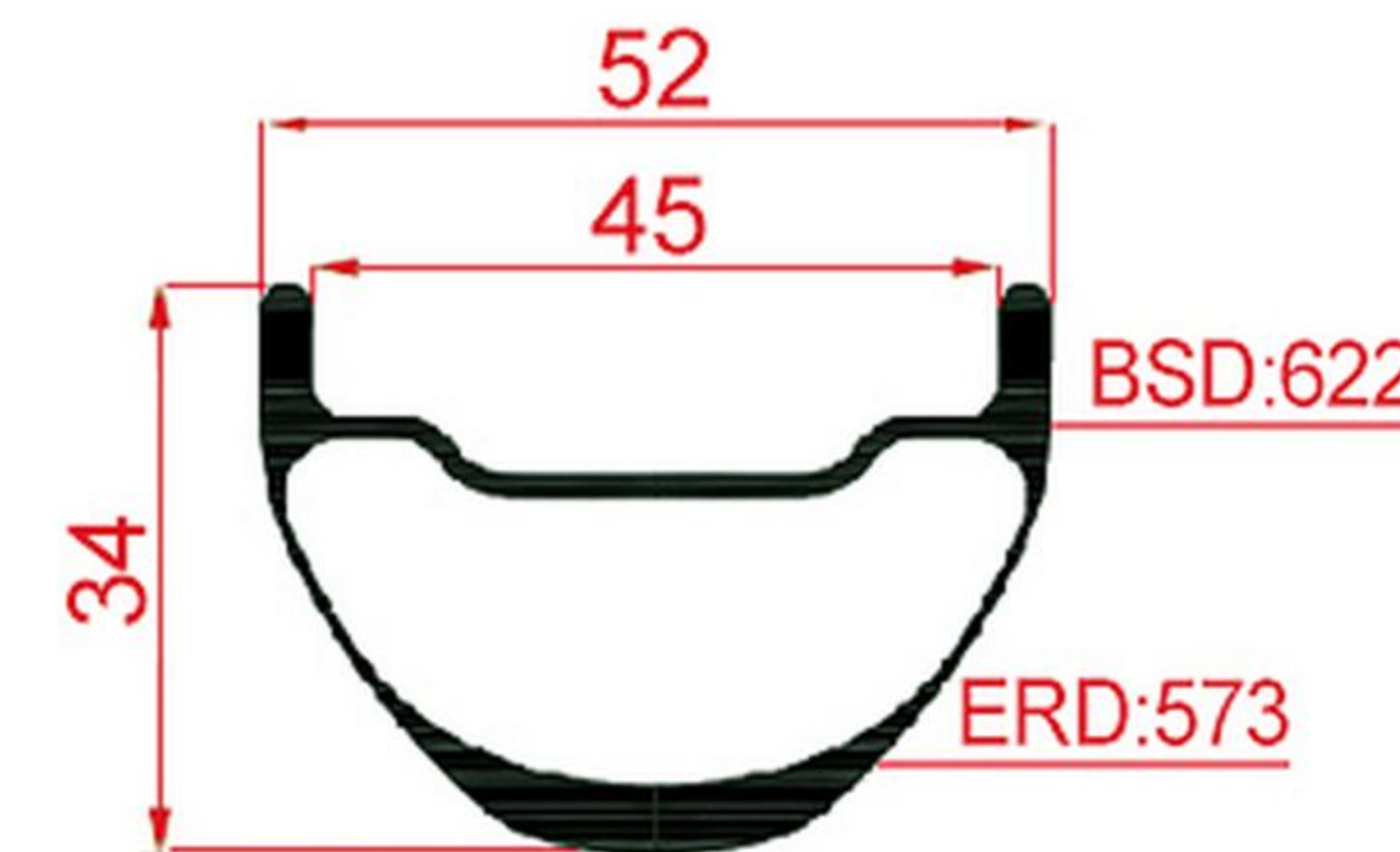

Model: M3452HL-29ER
Weight: AM: 560±10g
ERD: 573mm

► Carbon MTB DH Rims Series Symmetric

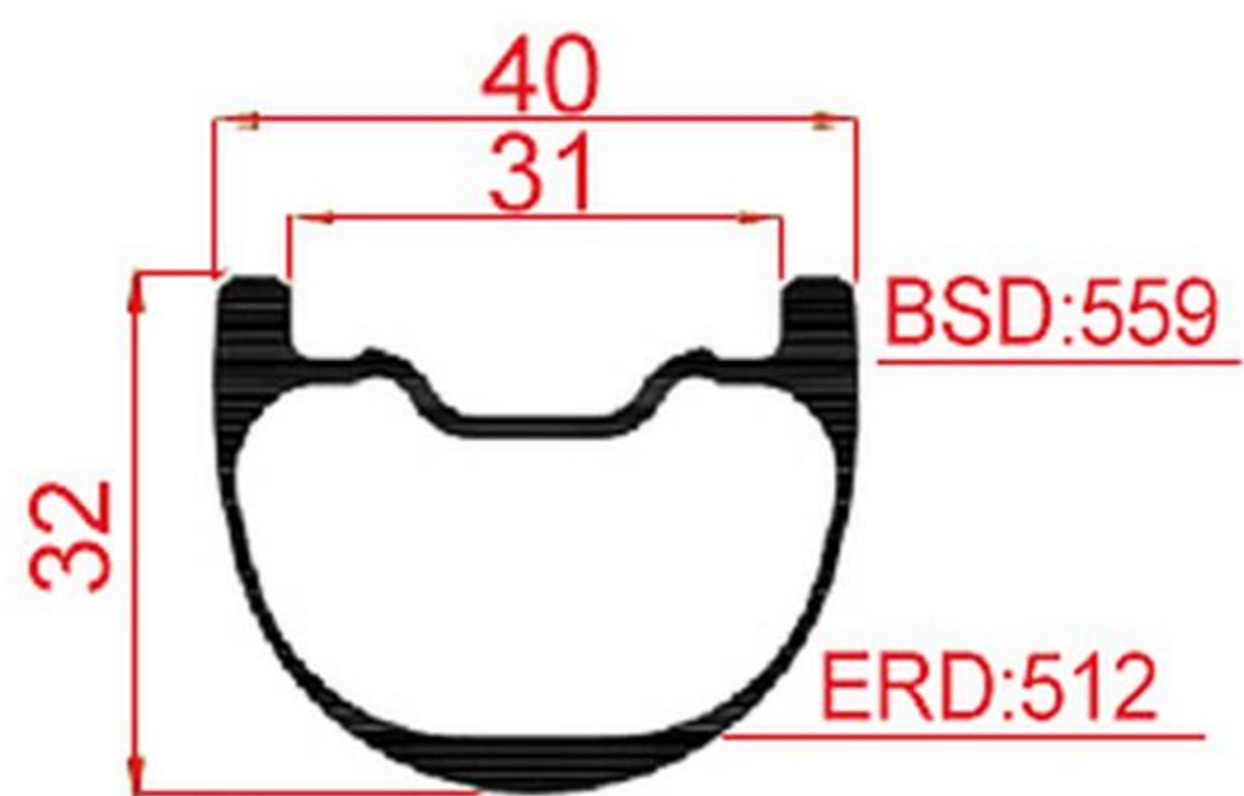

Model: M3240HL-26ER
Weight: DH: 550±15g
ERD: 512

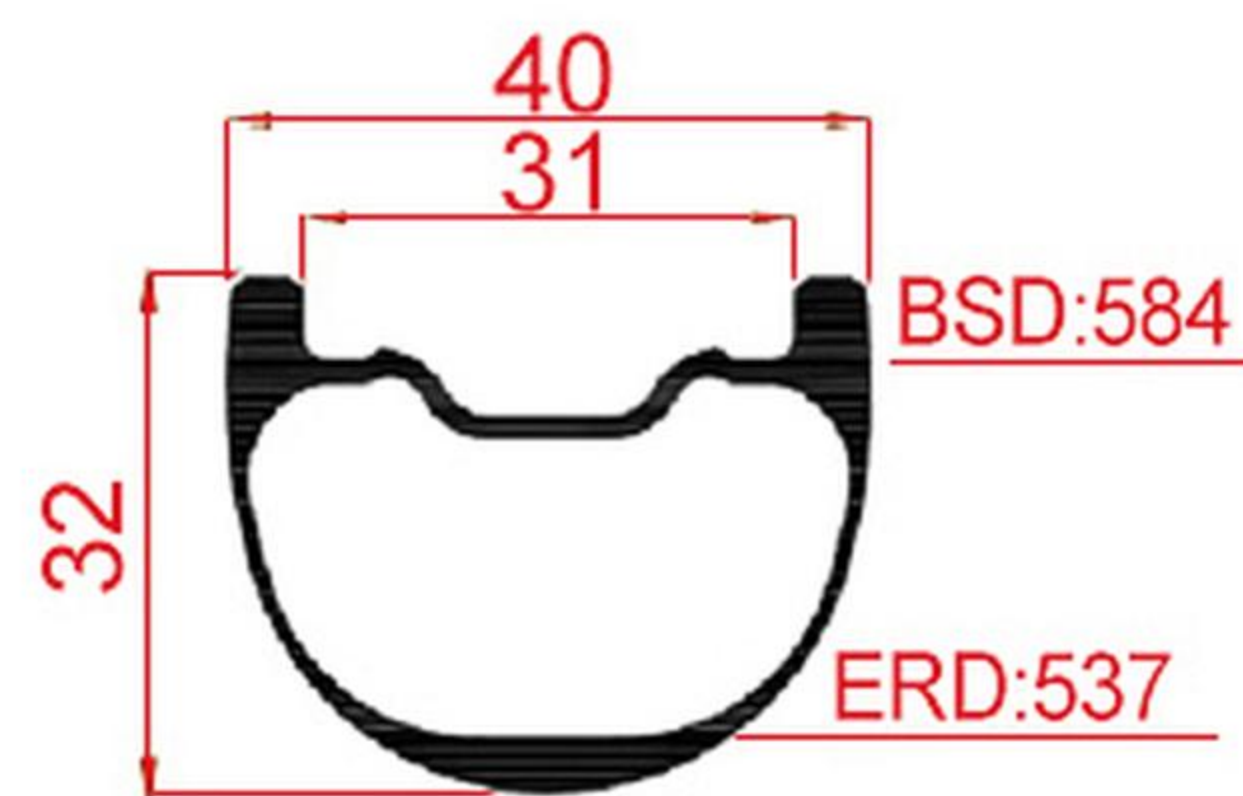

Model: M3240HL-27.5B
Weight: DH: 570±15g
ERD: 537

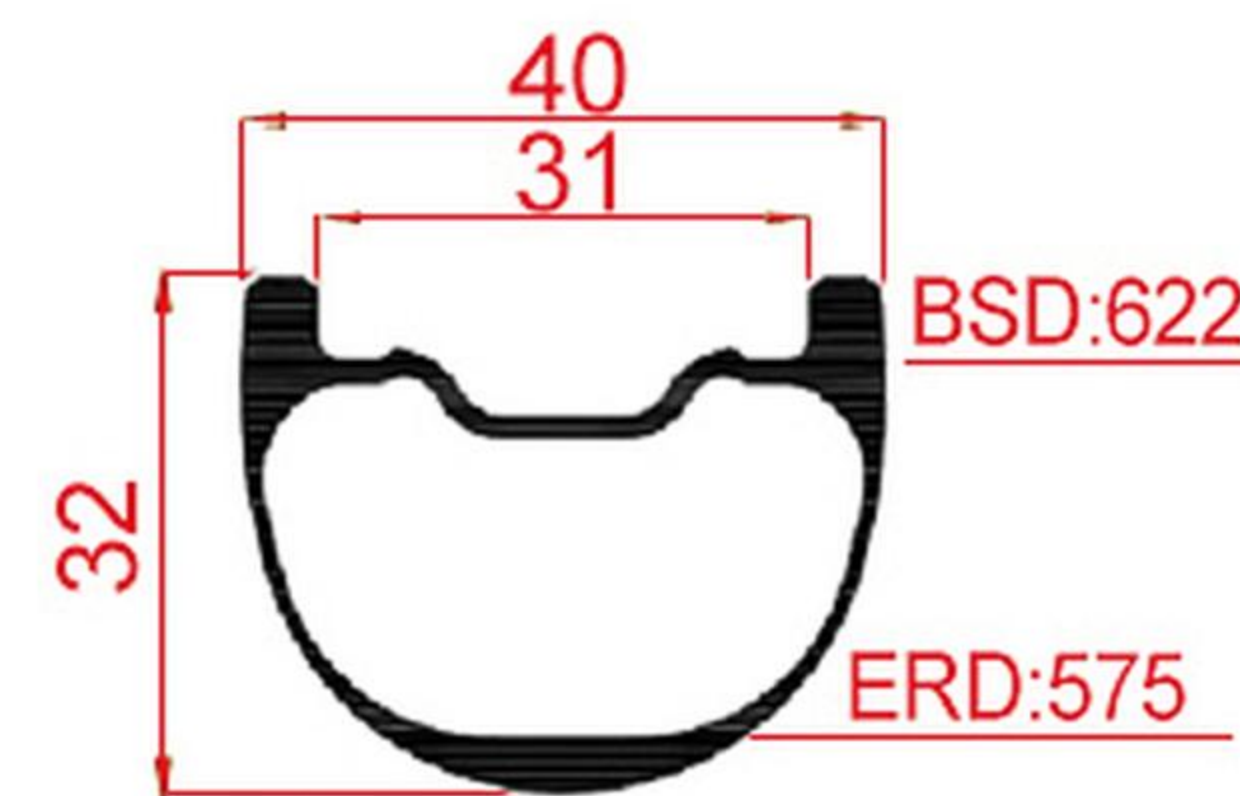

Model: M3240HL-29ER
Weight: DH: 600±15g
ERD: 575

► Carbon MTB XC/AM Rims Series Asymmetric

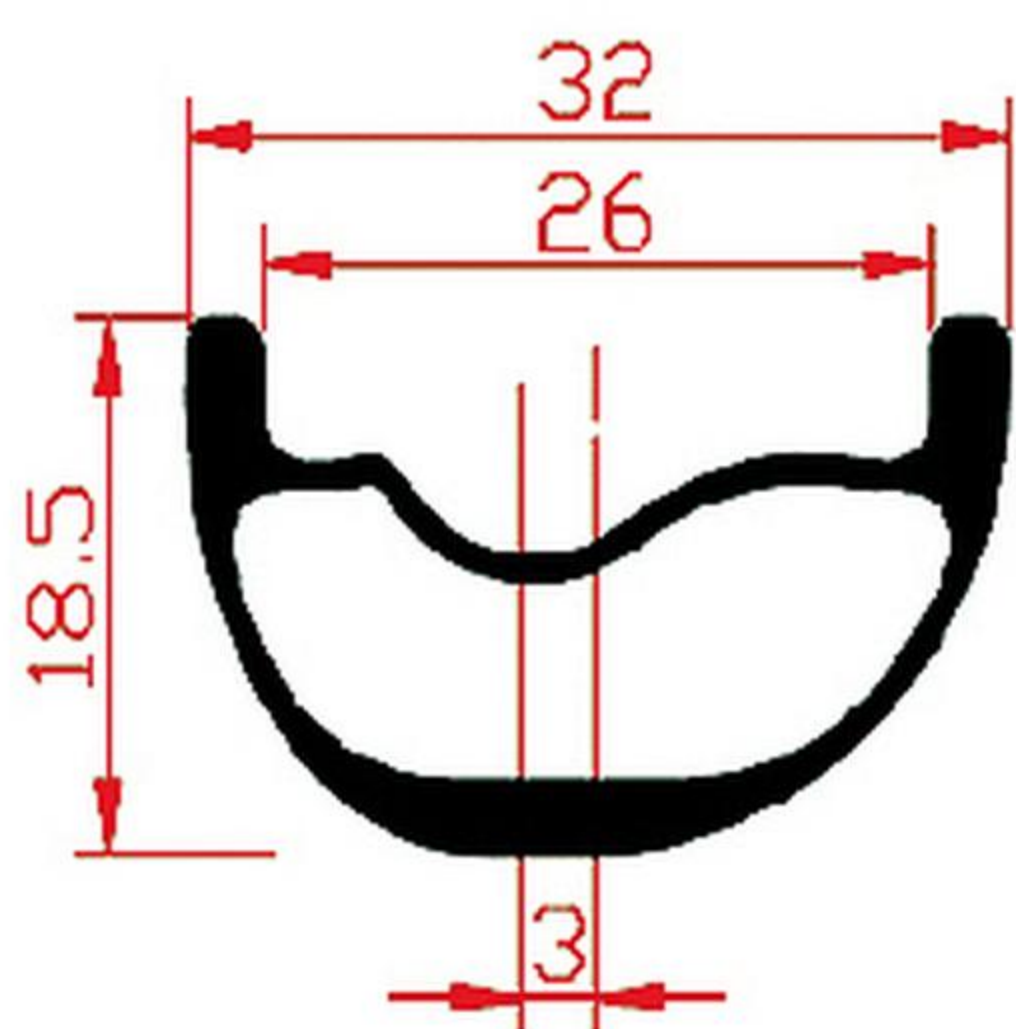

Model: M1832HL-29ER
 Weight: XC: 320±15g
 AM: 360±15g
 ERD: 602

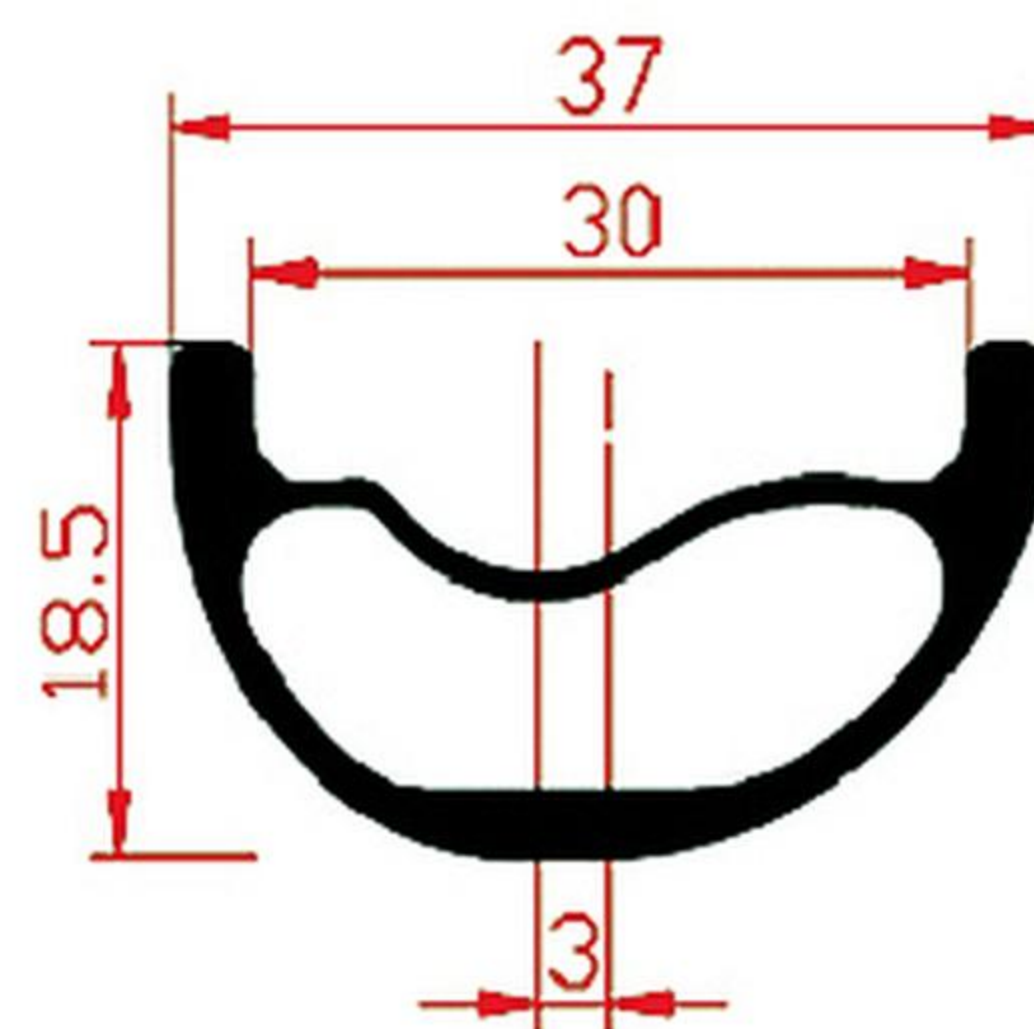

Model: M1837HL-29ER
 Weight: XC: 360±15g
 AM: 400±15g
 DH: 450±15g
 ERD: 602

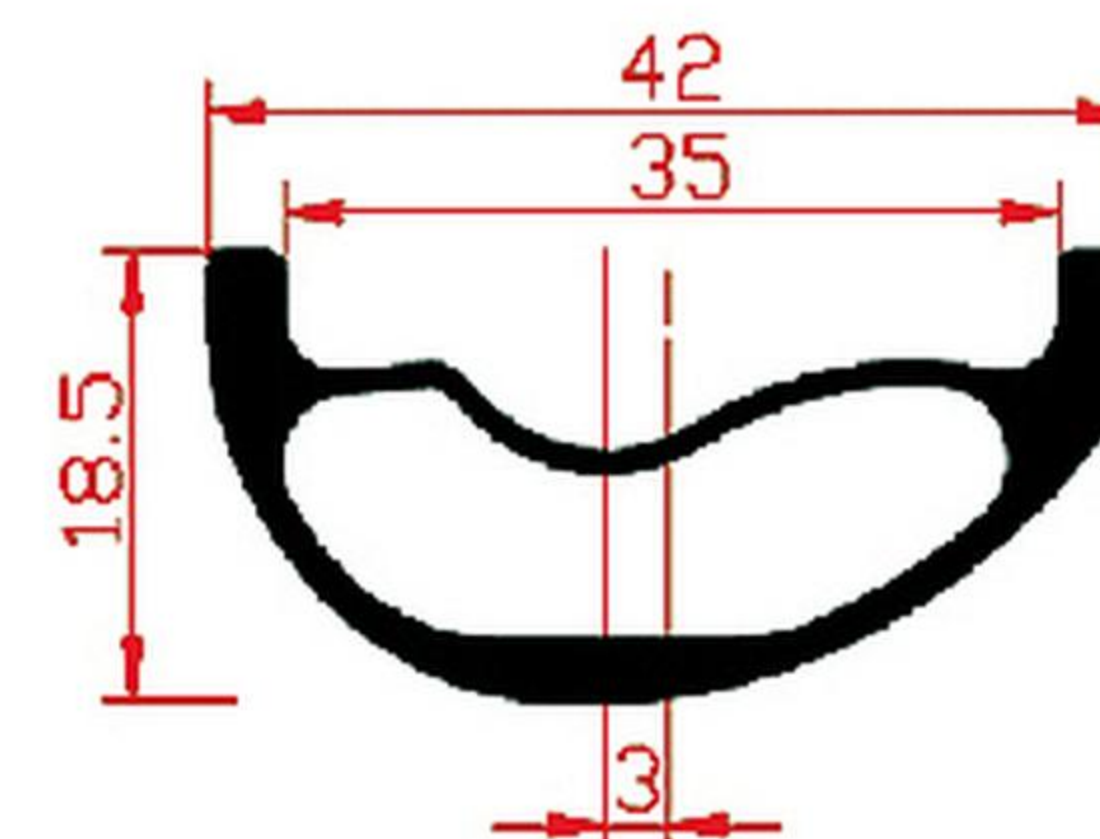

Model: M1842HL-29ER
 Weight: XC: 390±15g
 AM: 430±15g
 DH: 380±15g
 ERD: 602

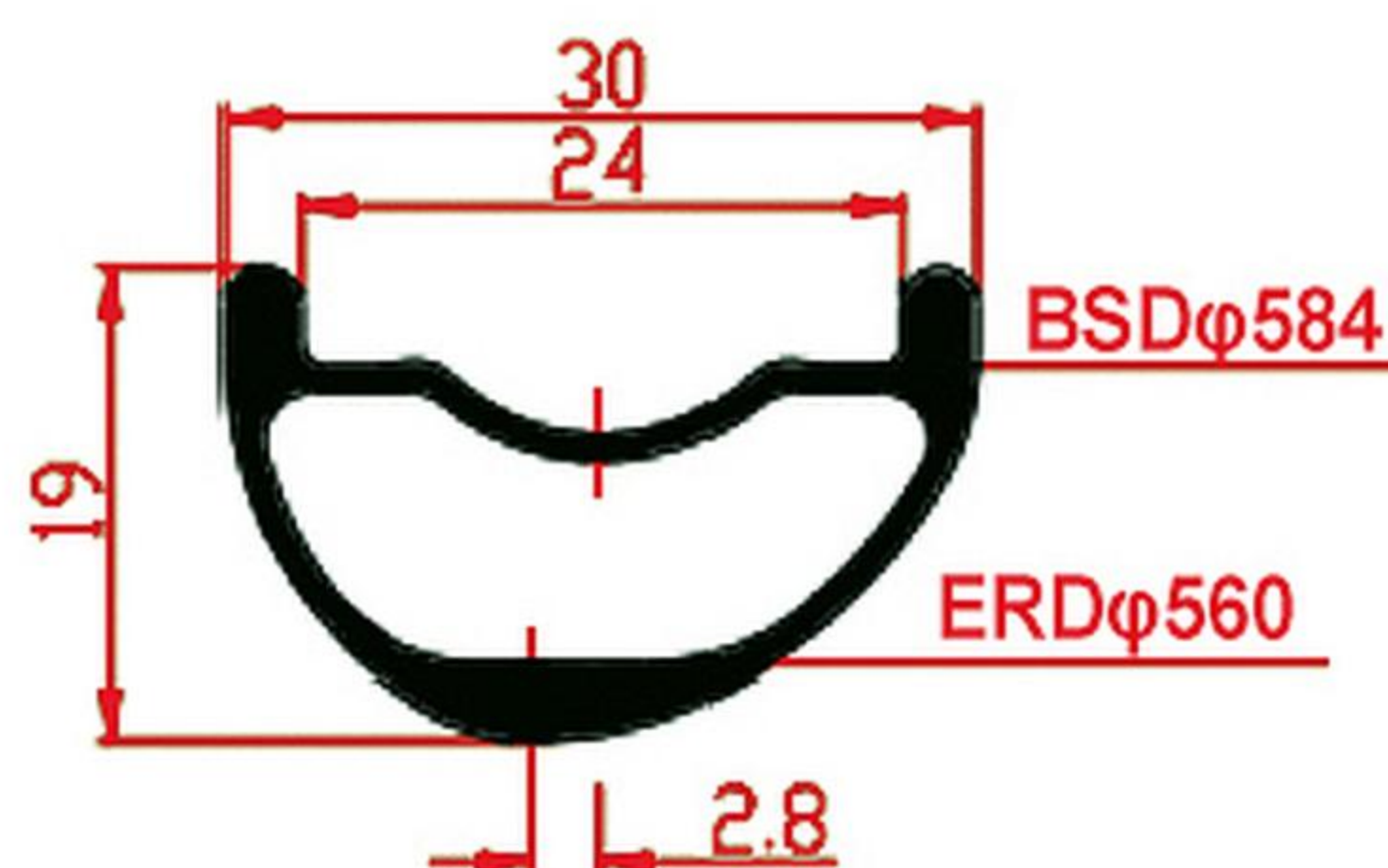

Model: M1930HL-27.5ER
 Weight: XC: 275±10g
 ERD: 560

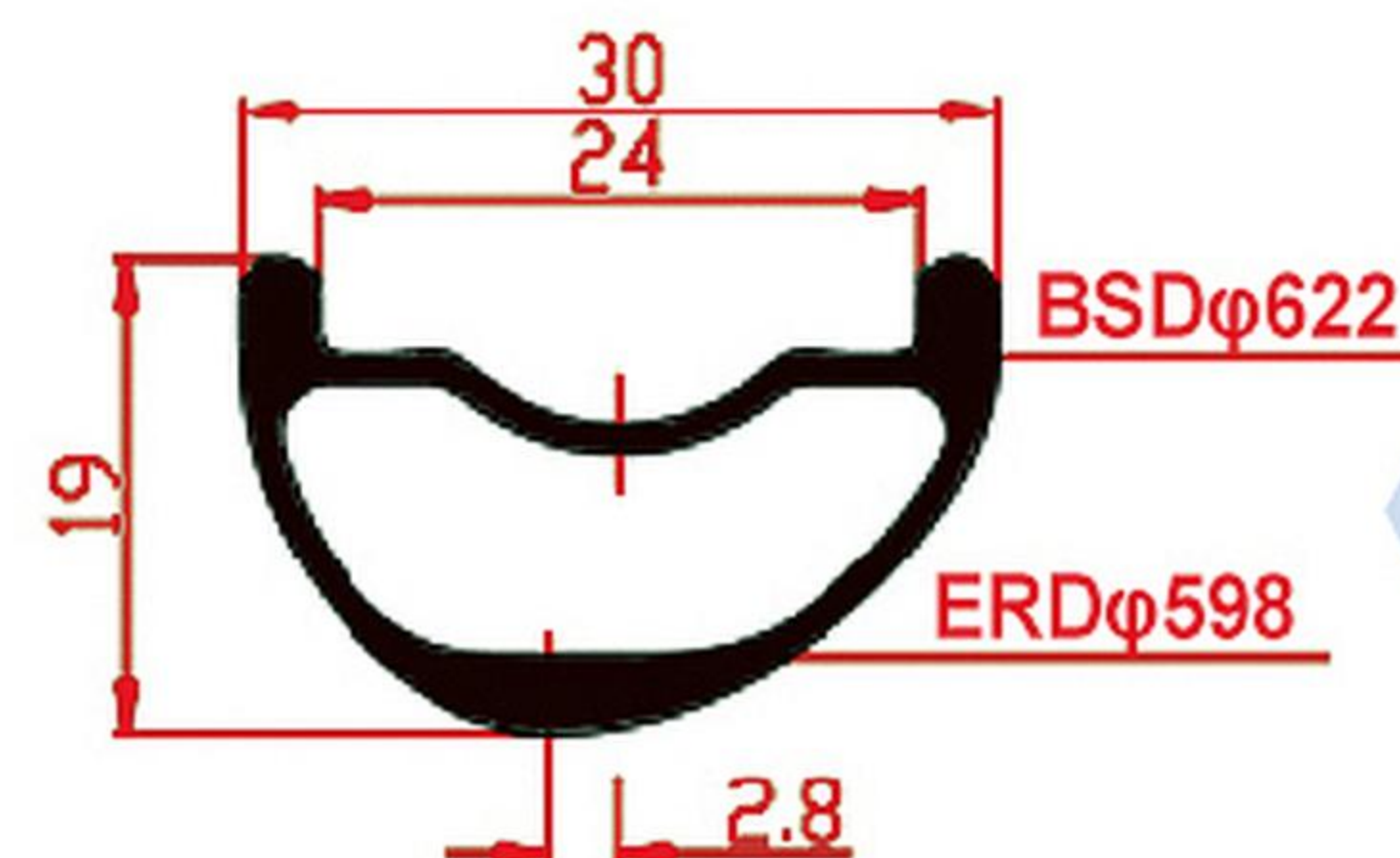

Model: M1930HL-29ER
 Weight: XC: 290±10g
 ERD: 598

► Carbon MTB XC/AM Rims Series Asymmetric

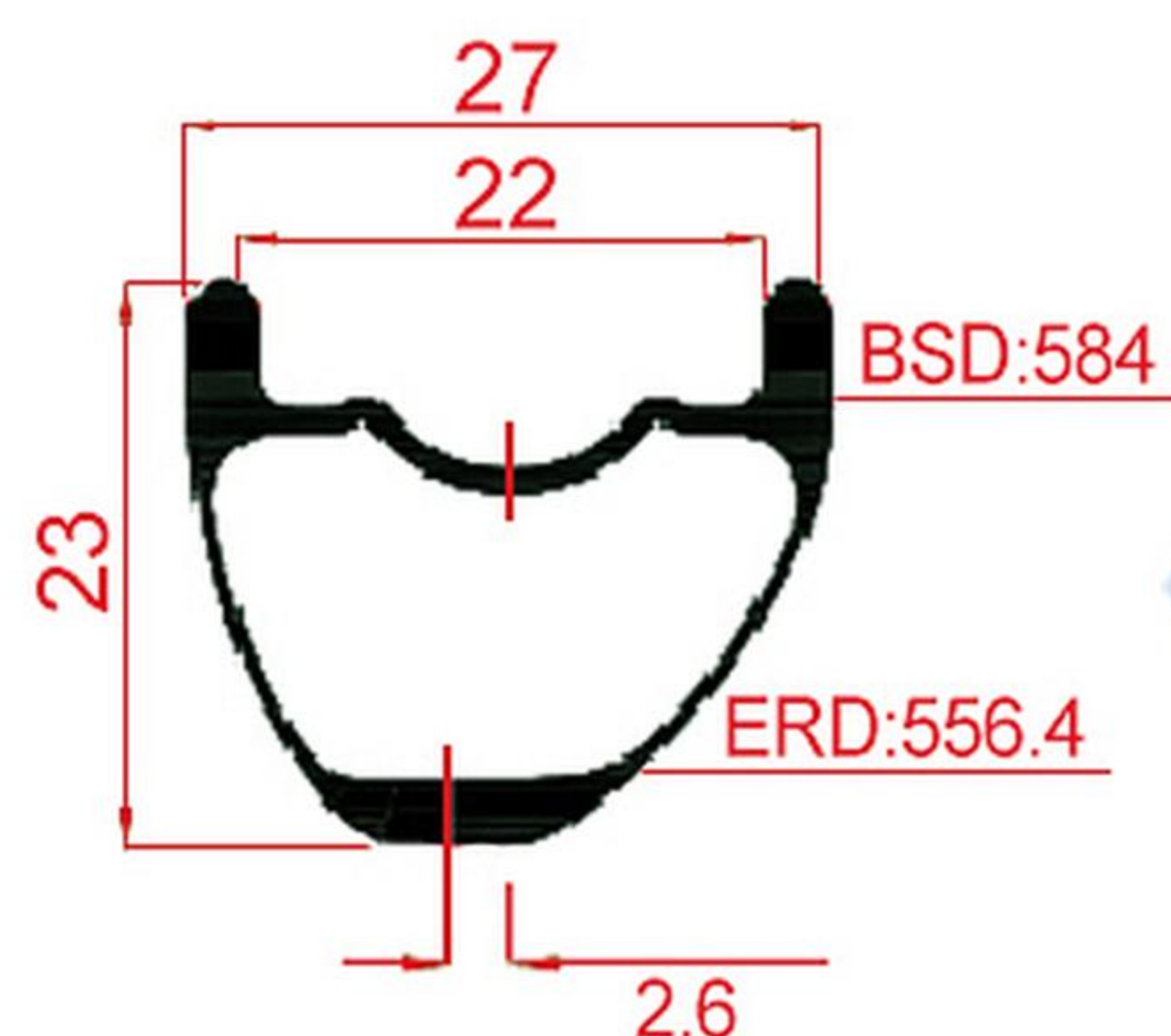

Model: M2327HL-27.5ER
Weight: XC: 255±10g
ERD: 556.4

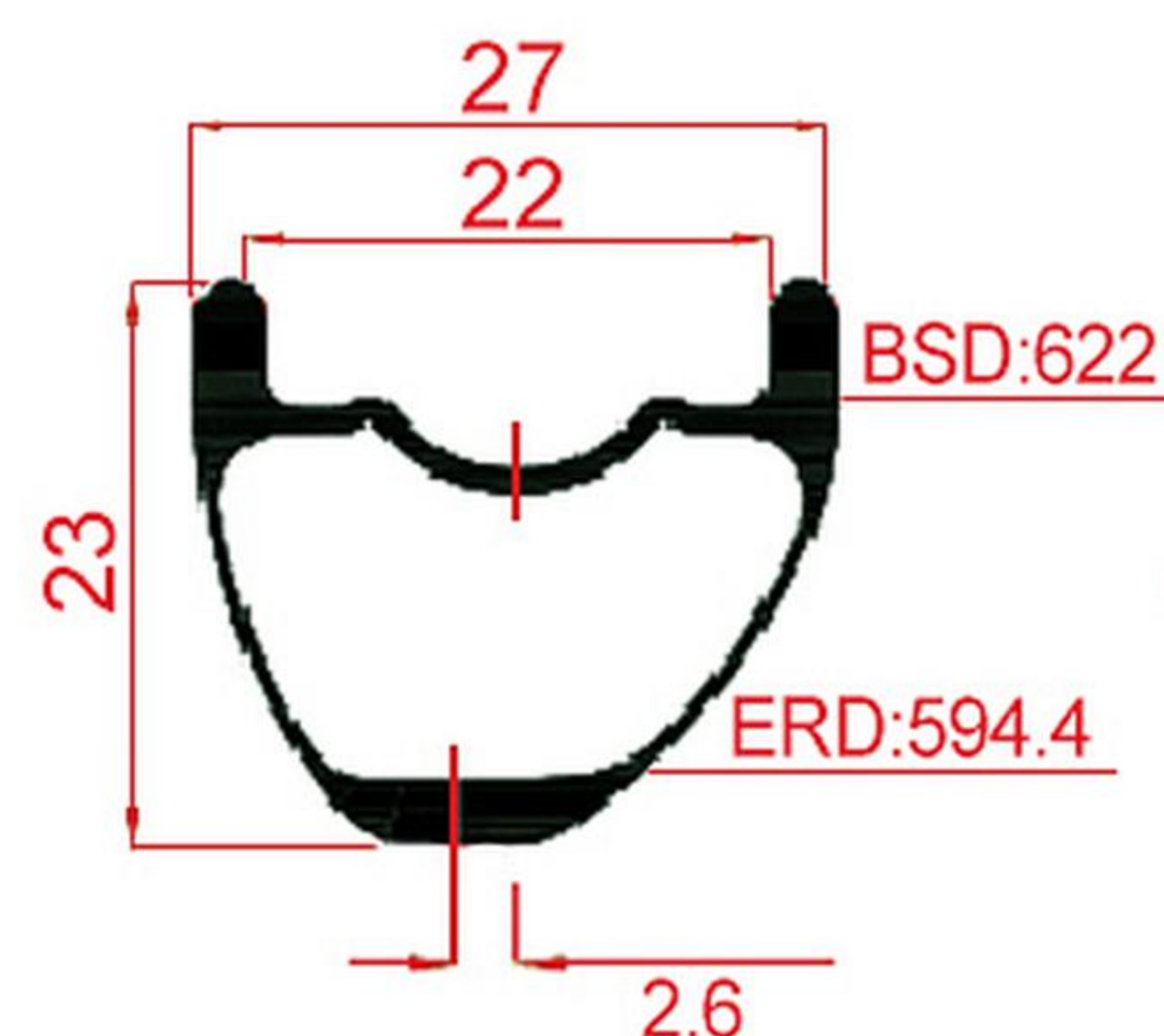

Model: M2327HL-29ER
Weight: XC: 270±10g
ERD: 594.4

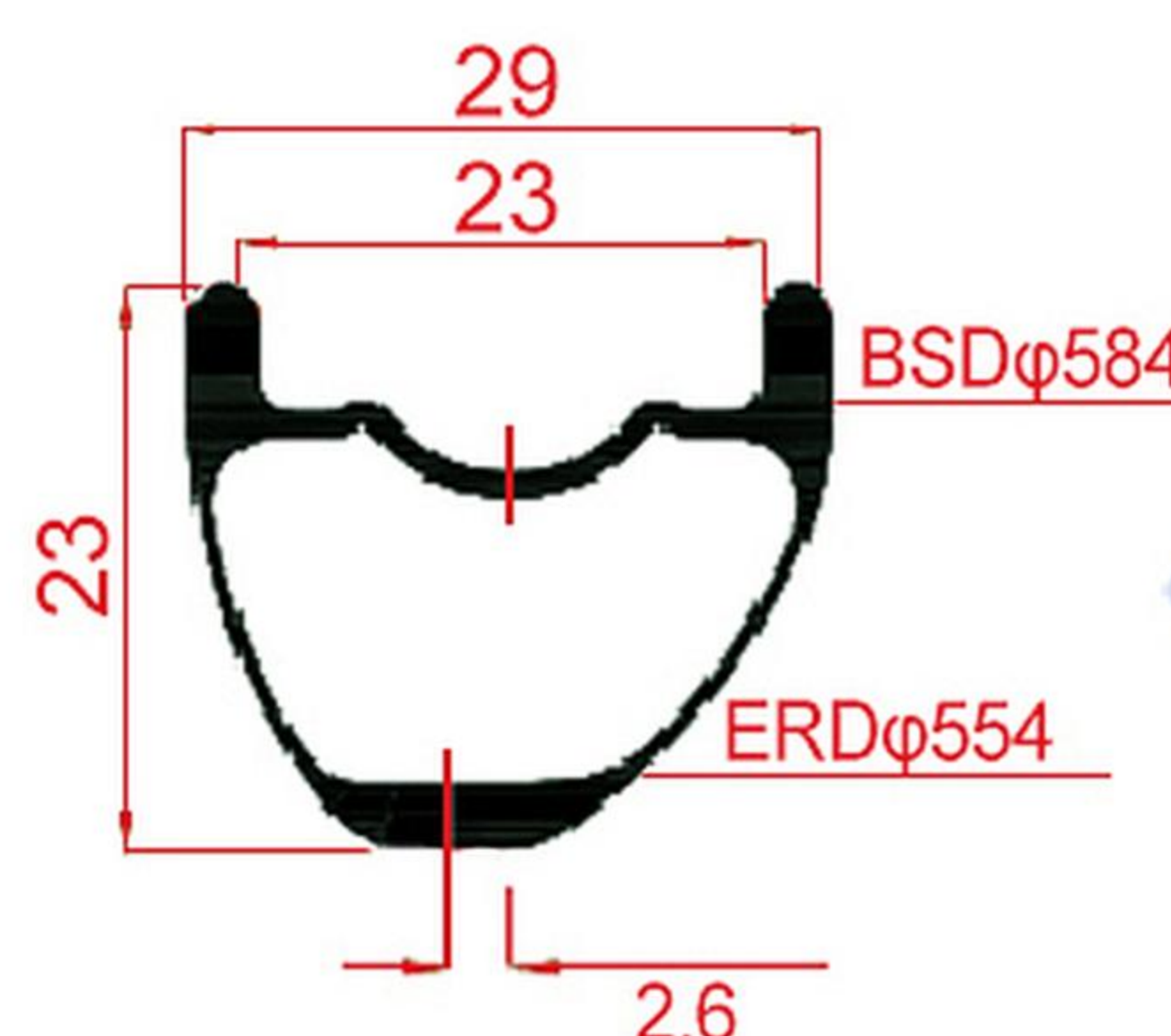

Model: M2329HL-27.5ER
Weight: XC: 275±10g
ERD: 554

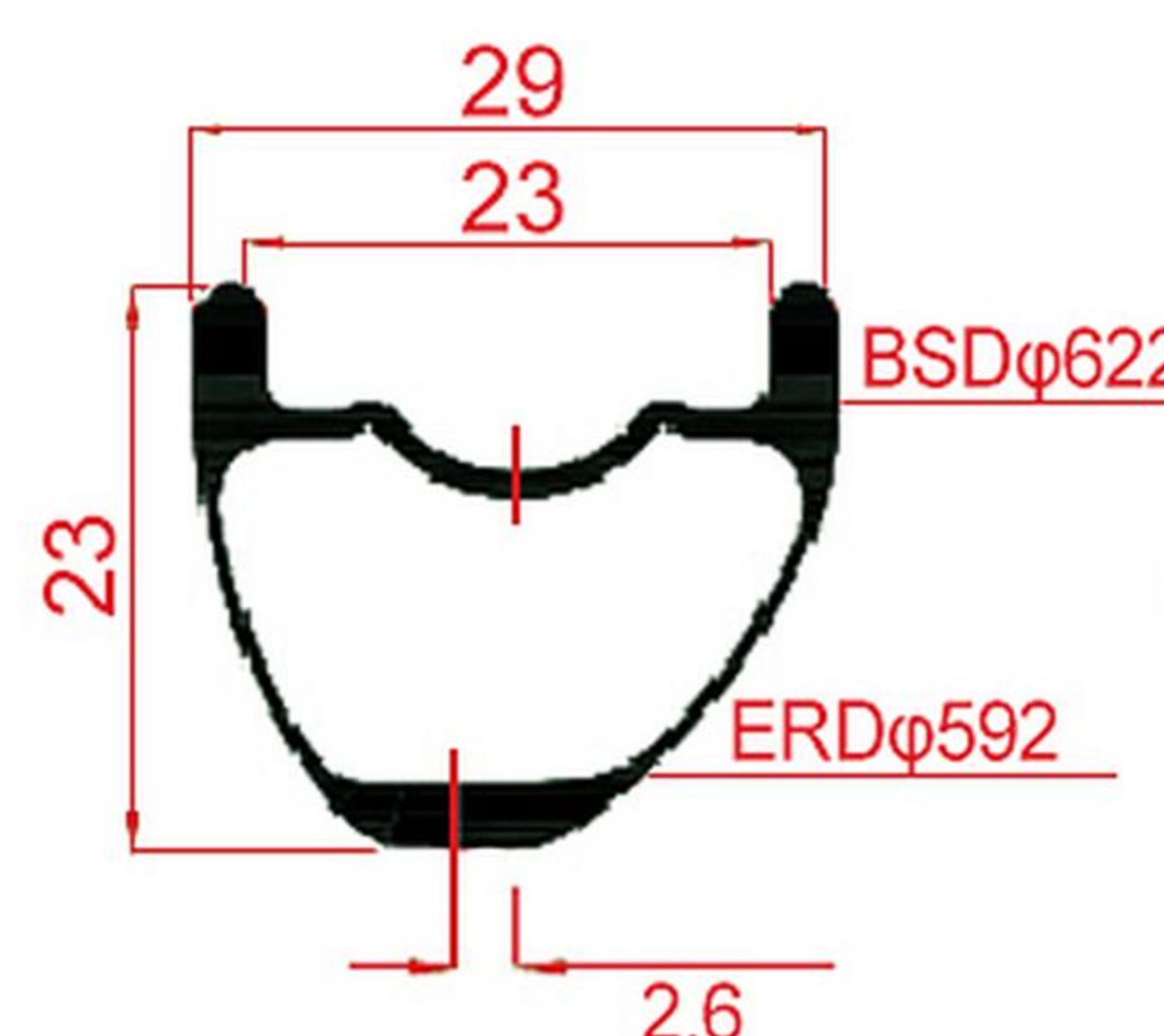

Model: M2329HL-29ER
Weight: XC: 290±10g
ERD: 592

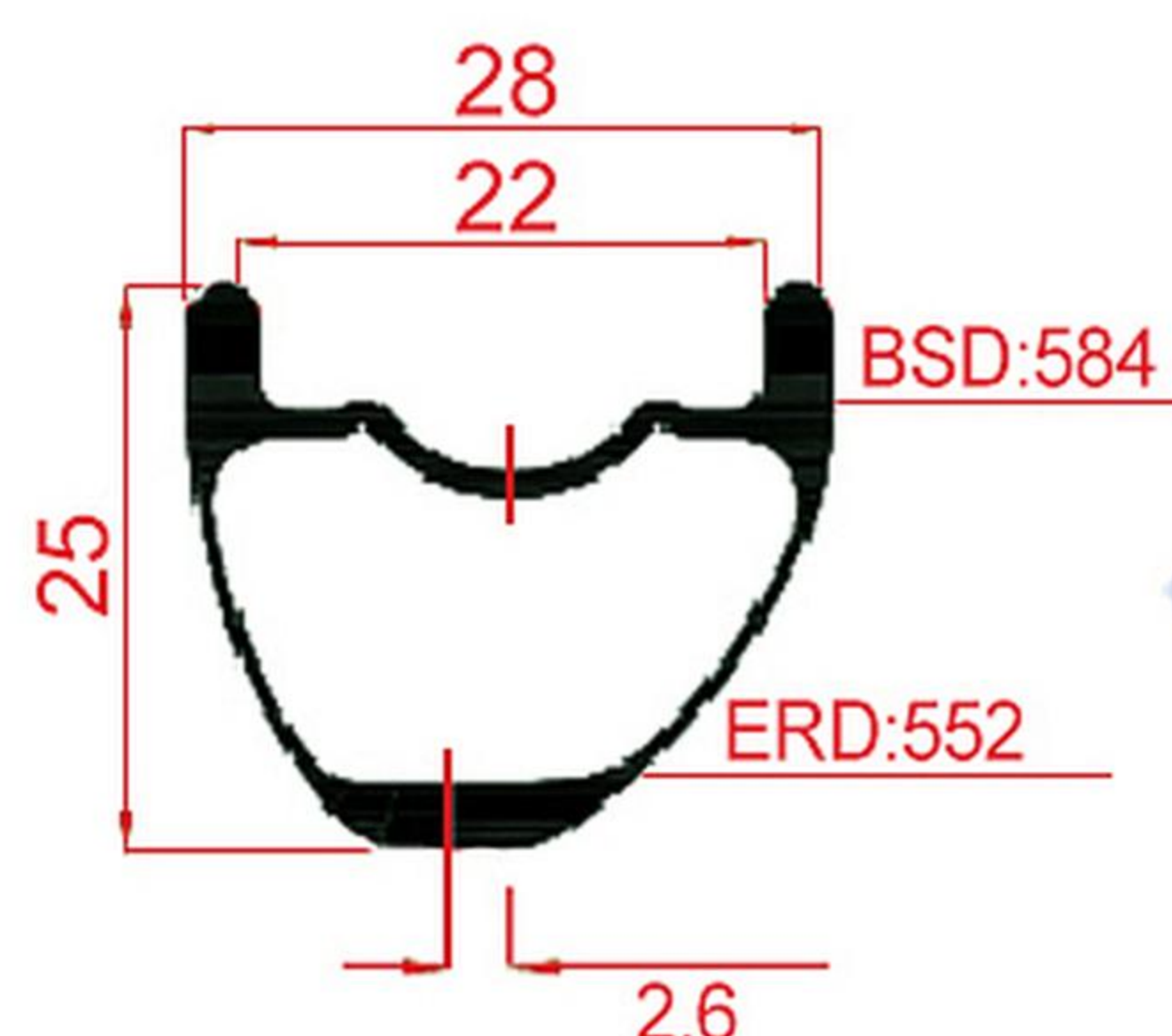

Model: M2528HL-27.5ER
Weight: XC: 275±10g
ERD: 552

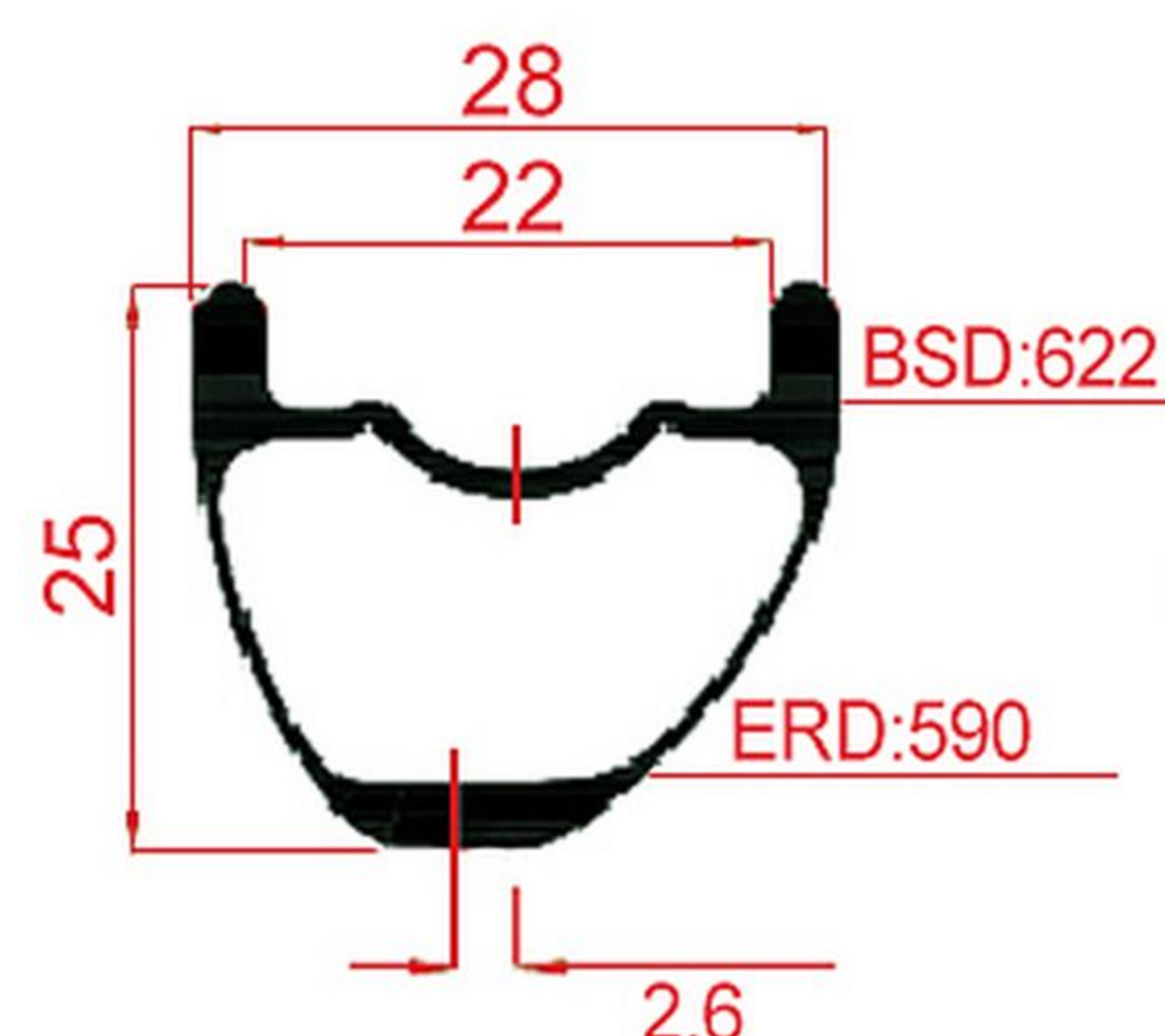

Model: M2528HL-29ER
Weight: XC: 290±10g
ERD: 590

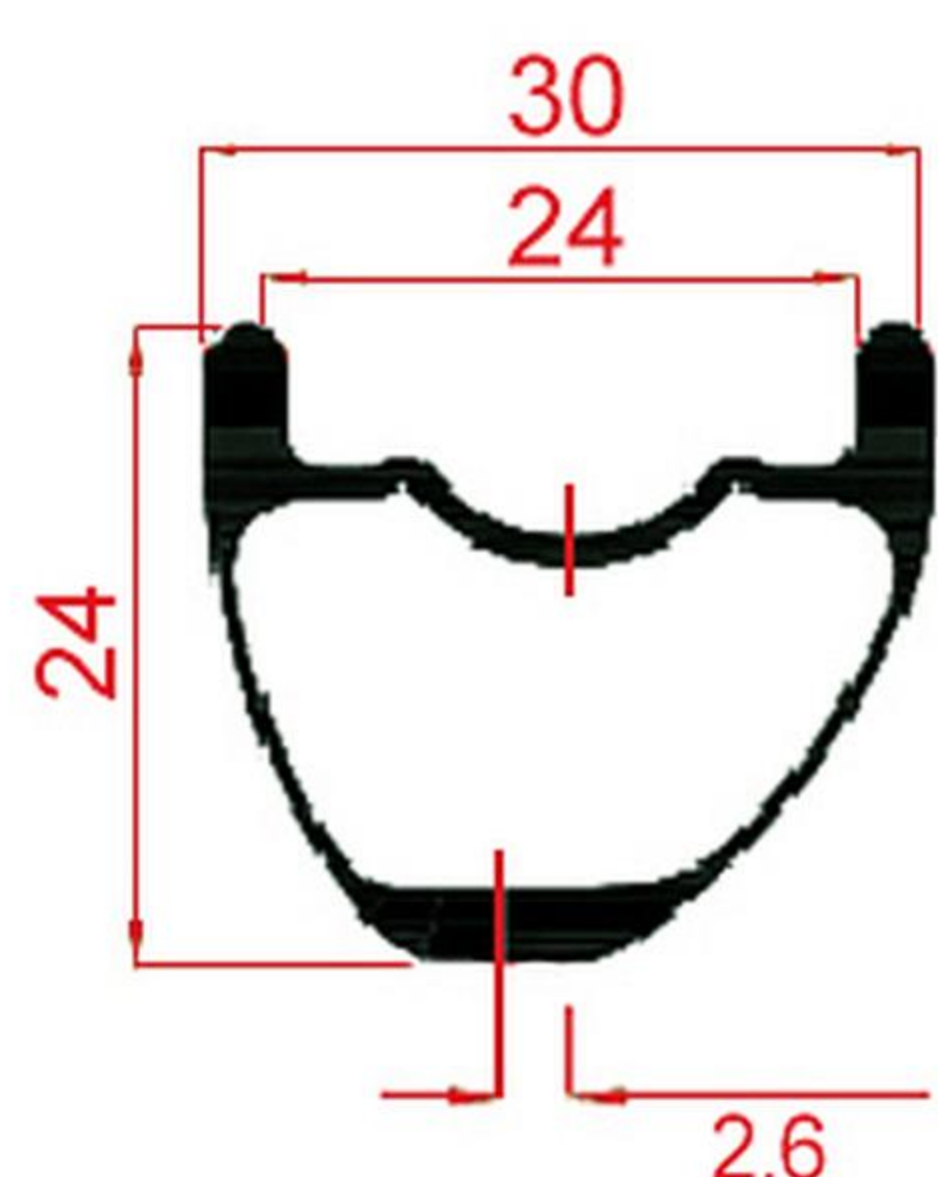

Model: M2430HL-27.5ER
Weight: XC: 300±15g
AM: 340±15g
ERD: 553

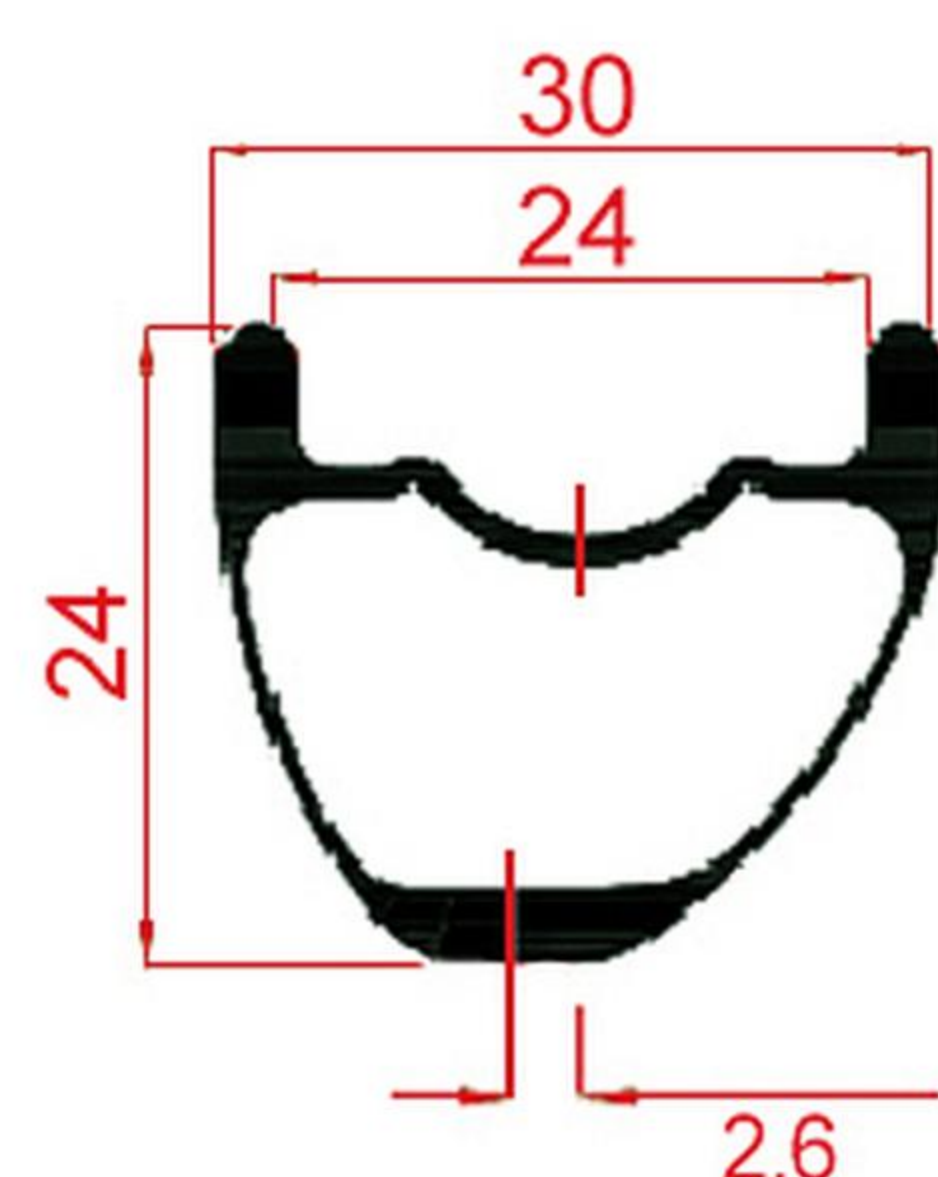

Model: M2430HL-29ER
Weight: XC: 320±15g
AM: 365±15g
ERD: 591

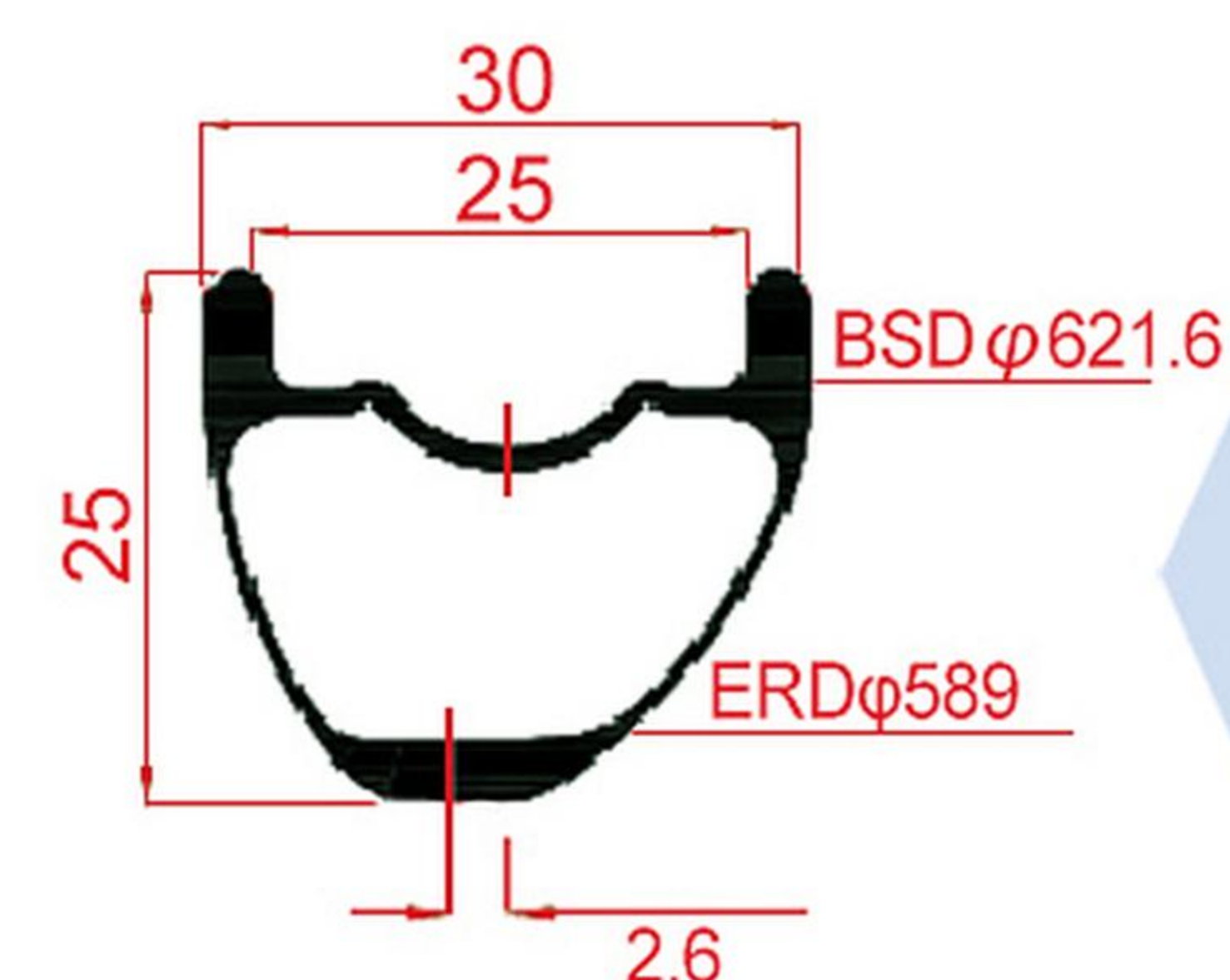

Model: M2530HL-29ER
Weight: XC: 310±10g
ERD: 589

► Carbon MTB XC/AM Rims Series Asymmetric

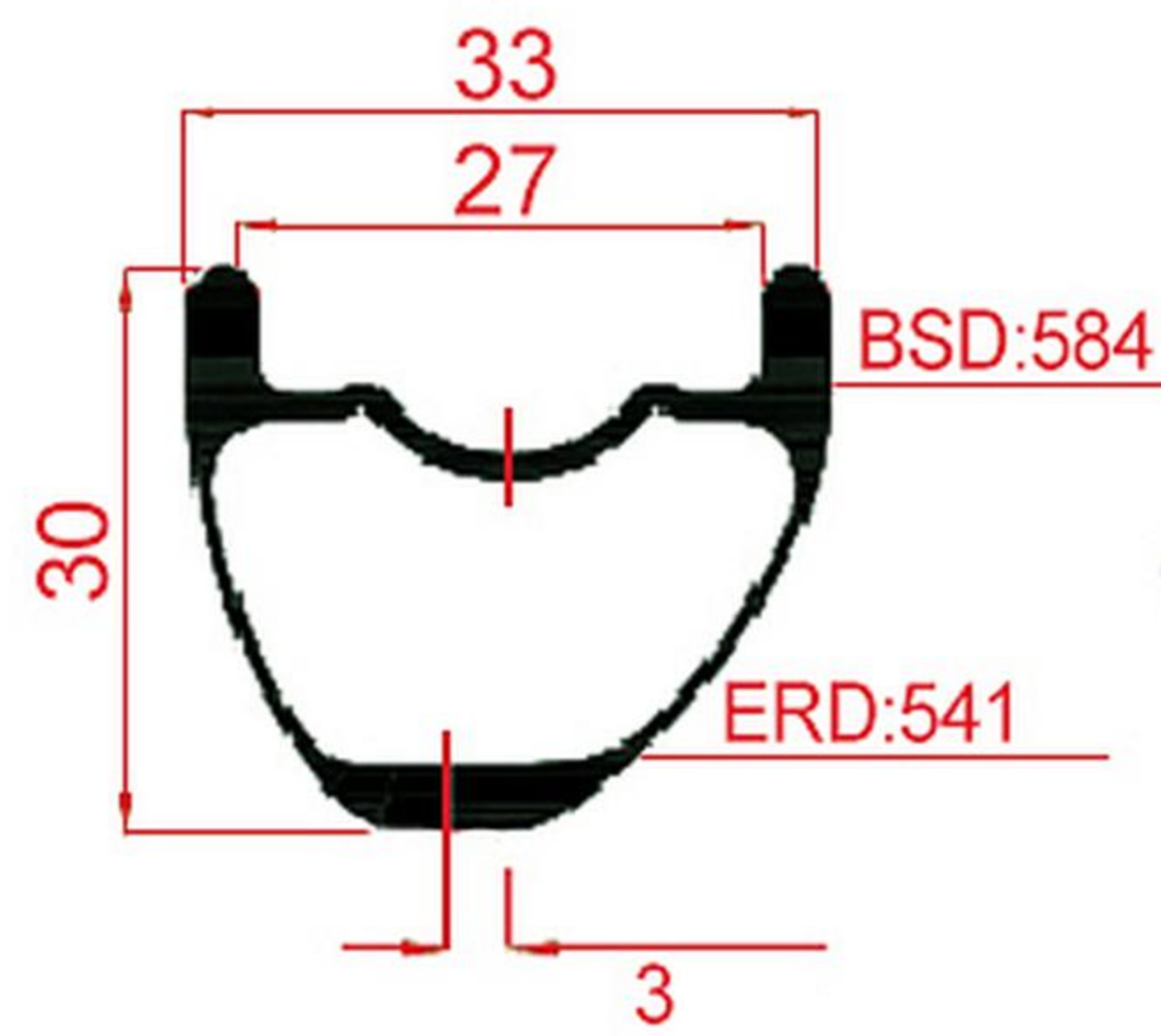

Model: M3033HL-27.5ER
Weight: XC: 375±10g
ERD: 541

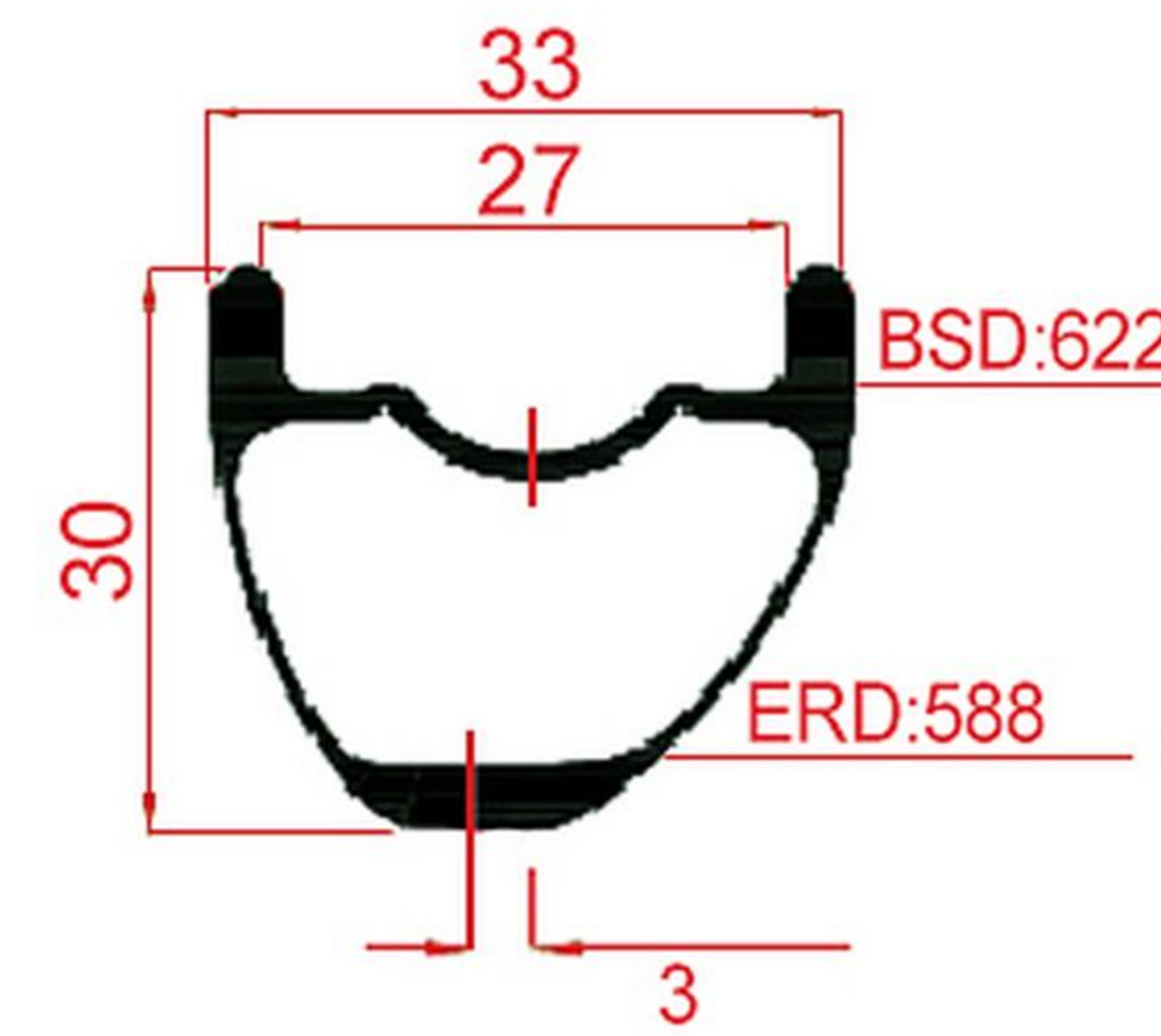

Model: M3033HL-29ER
Weight: XC: 390±10g
ERD: 588

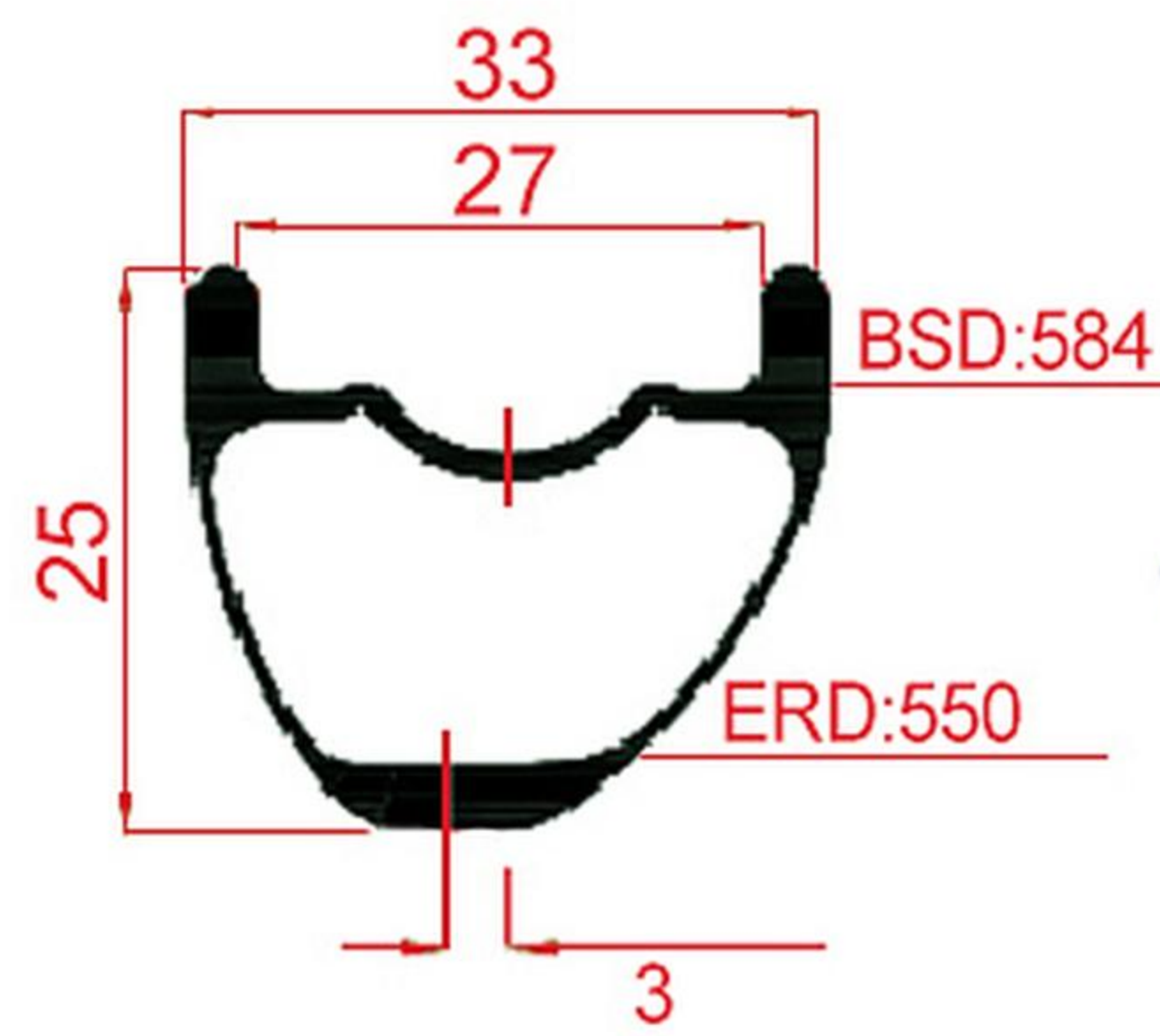

Model: M2533HL-27.5ER
Weight: XC: 350±10g
ERD: 550

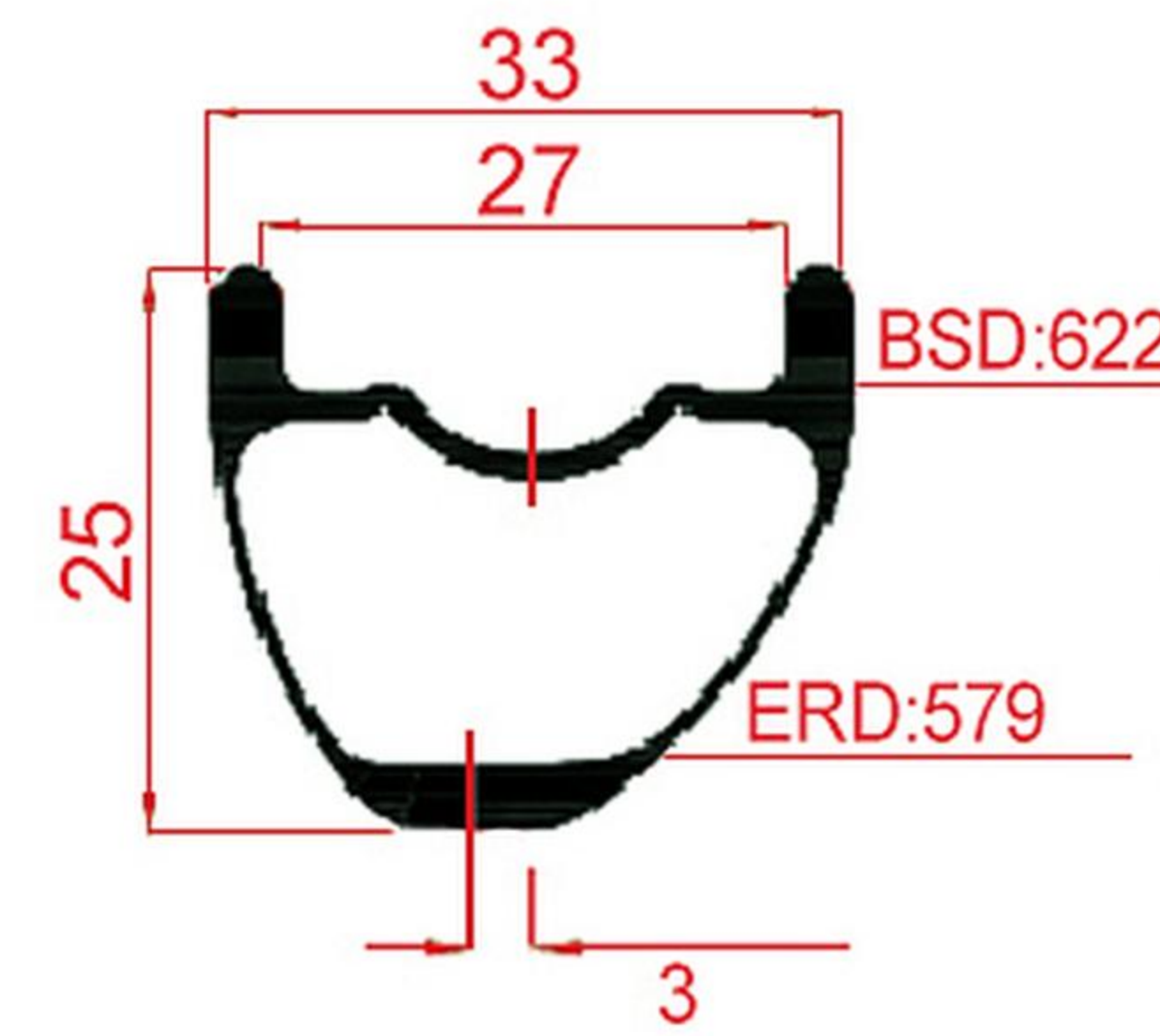

Model: M2533HL-29ER
Weight: XC: 365±10g
ERD: 579

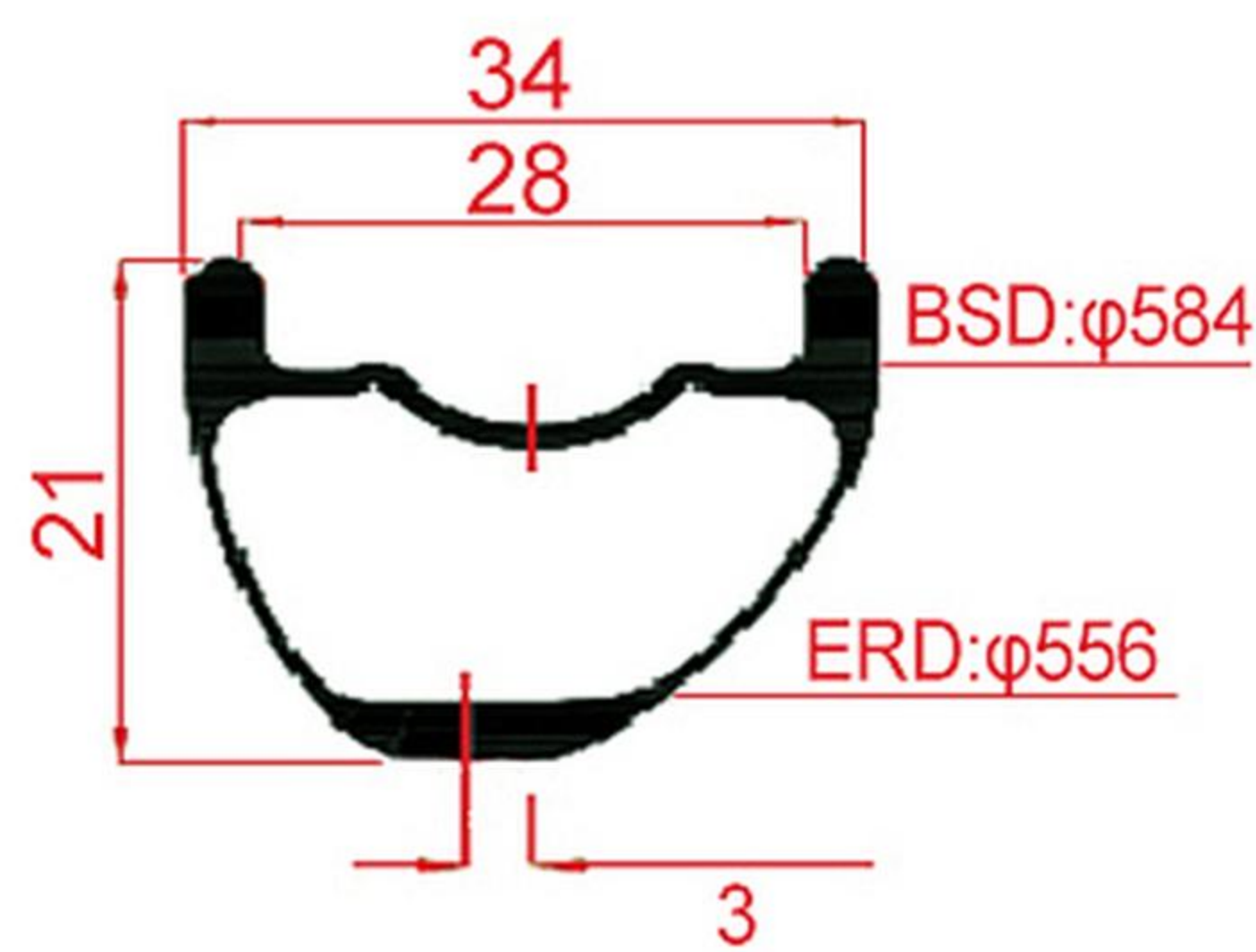

Model: M2134HL-27.5ER
Weight: XC: 320±10g
ERD: 556

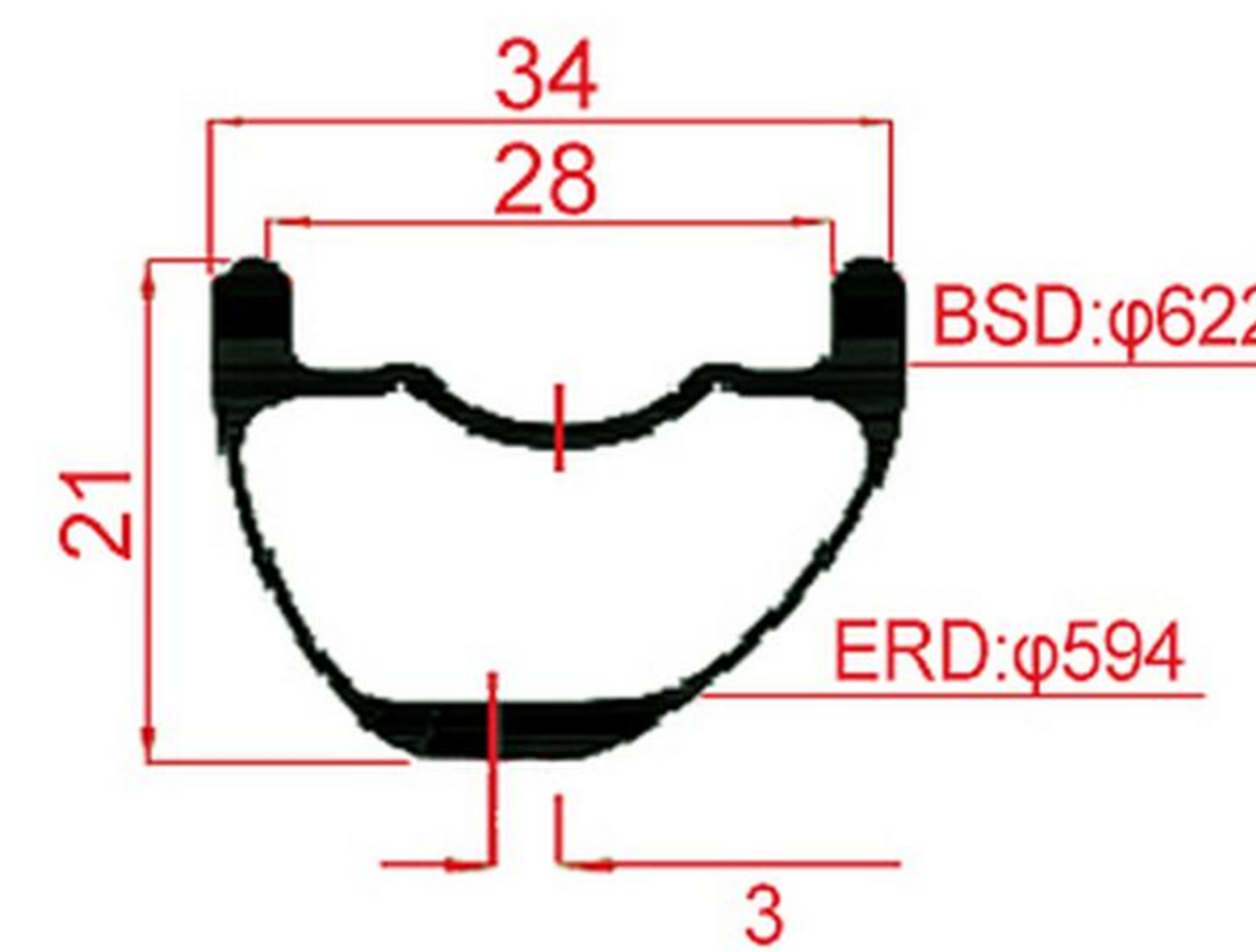

Model: M2134HL-29ER
Weight: XC: 335±10g
ERD: 594

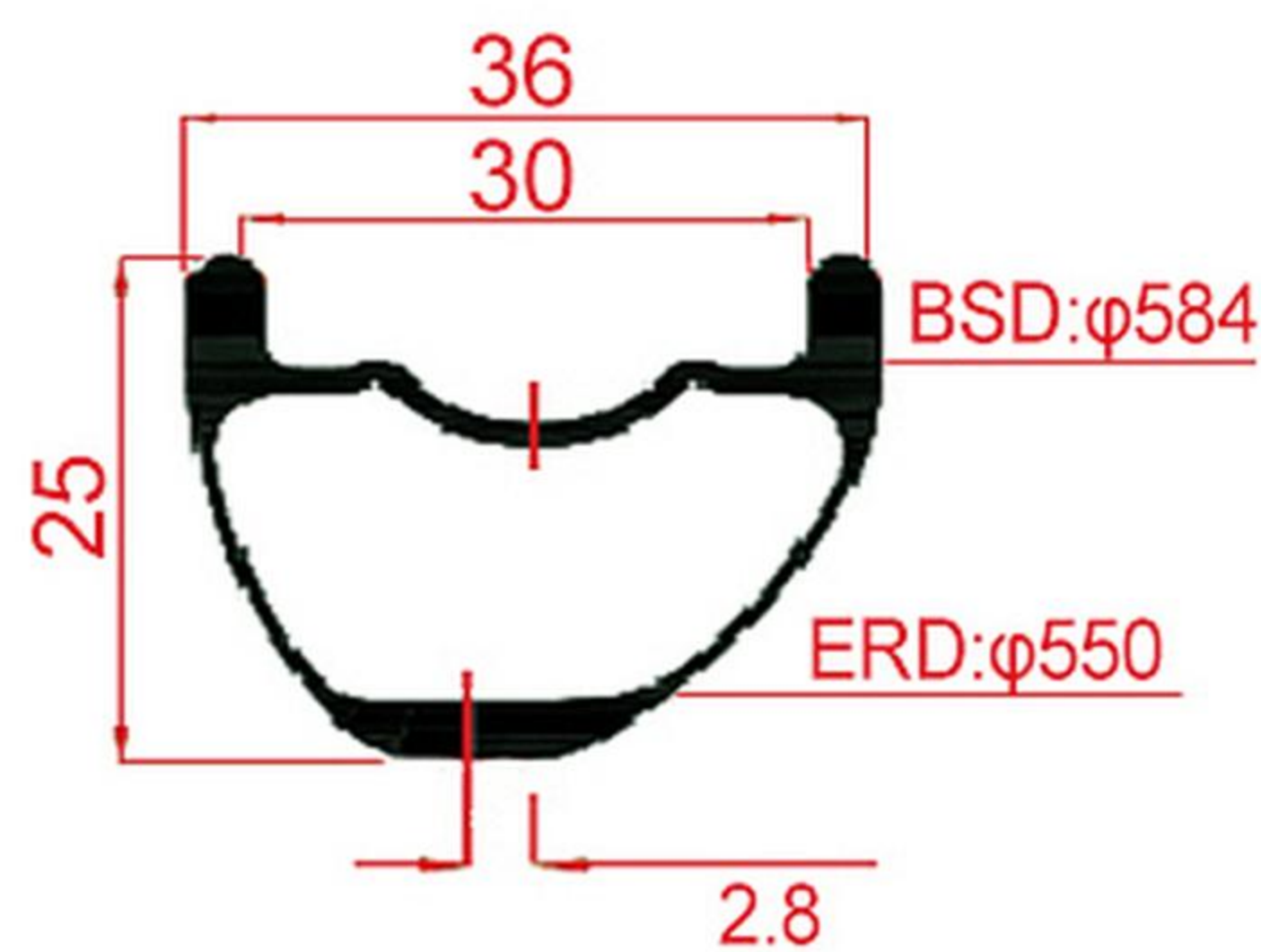

Model: M2536HL-27.5ER
Weight: XC/AM: 355±10g
ERD: 550

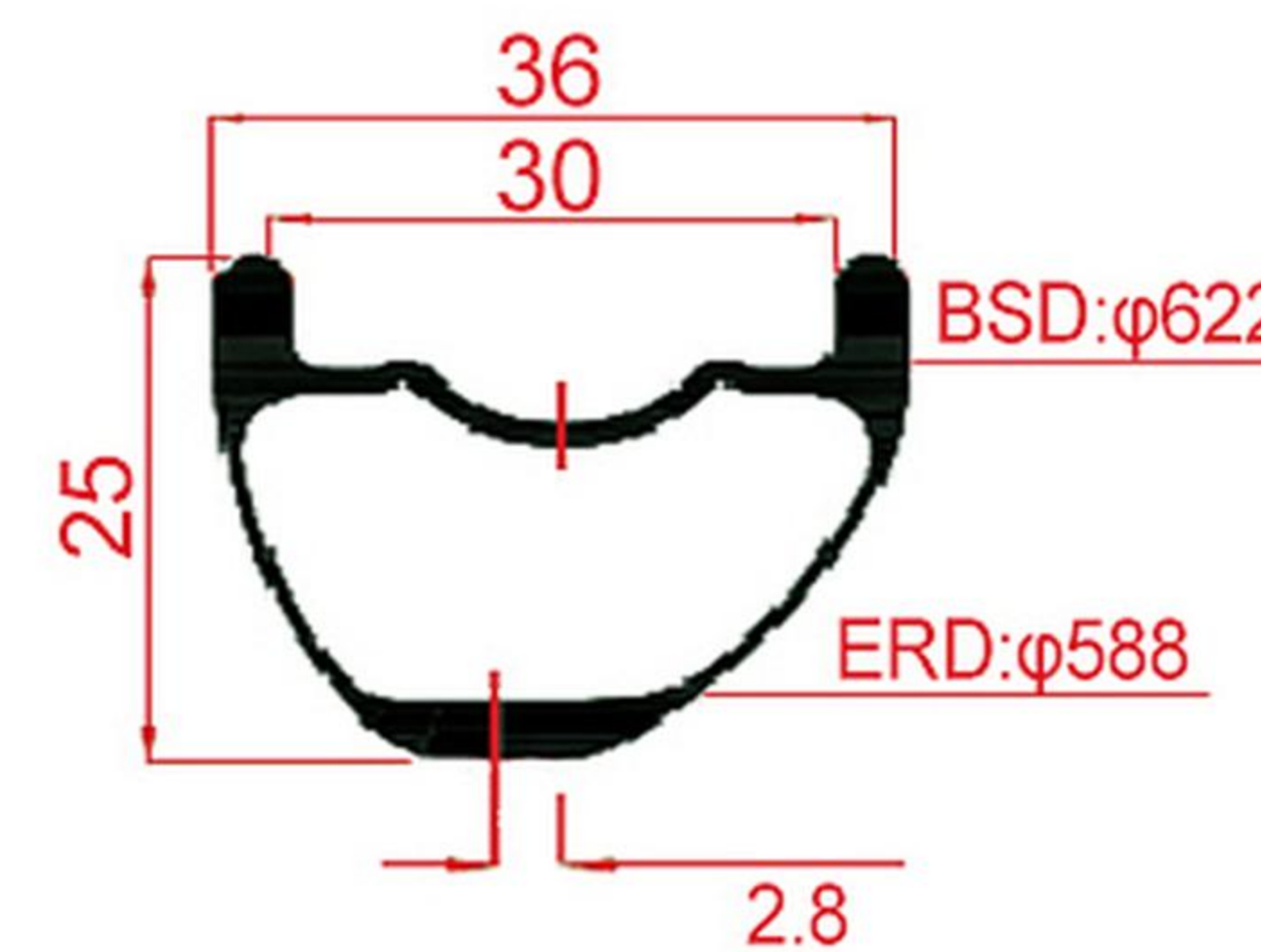

Model: M2536HL-29ER
Weight: XC/AM: 370±10g
ERD: 588

► Carbon MTB XC/AM Rims Series Asymmetric

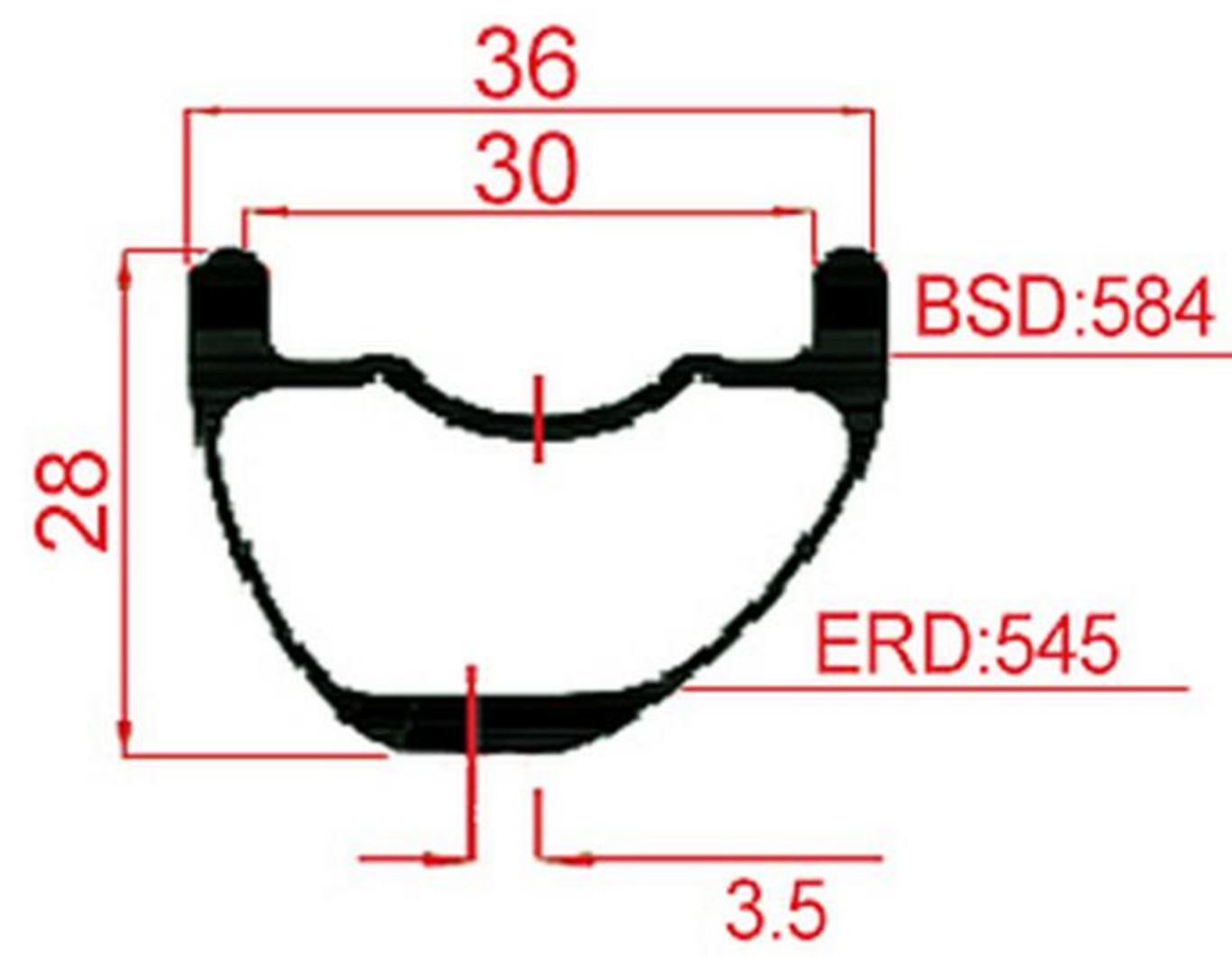

Model: M2836HL-27.5ER
Weight: XC/AM: 370±10g
ERD: 545

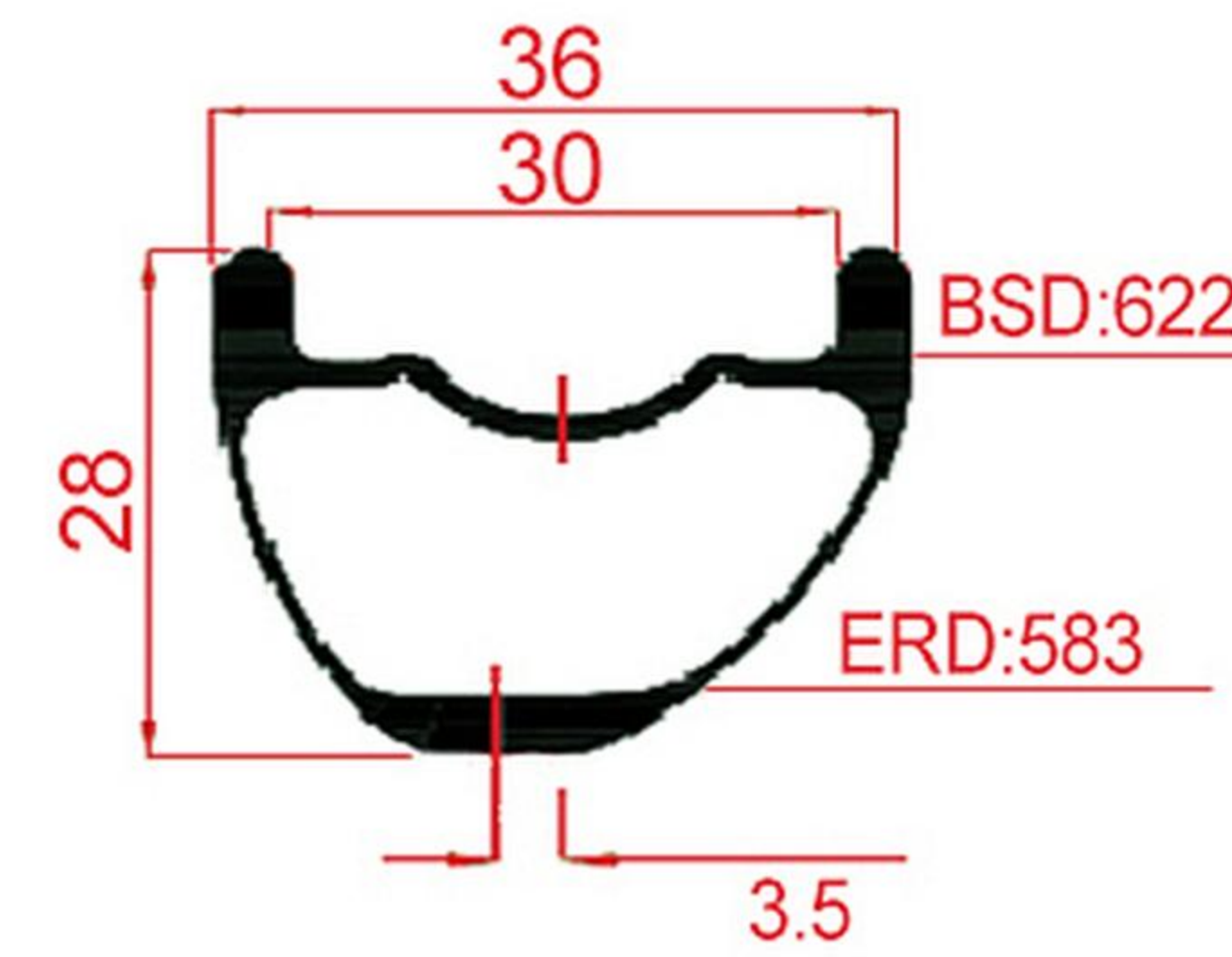

Model: M2836HL-29ER
Weight: XC/AM: 390±10g
ERD: 583

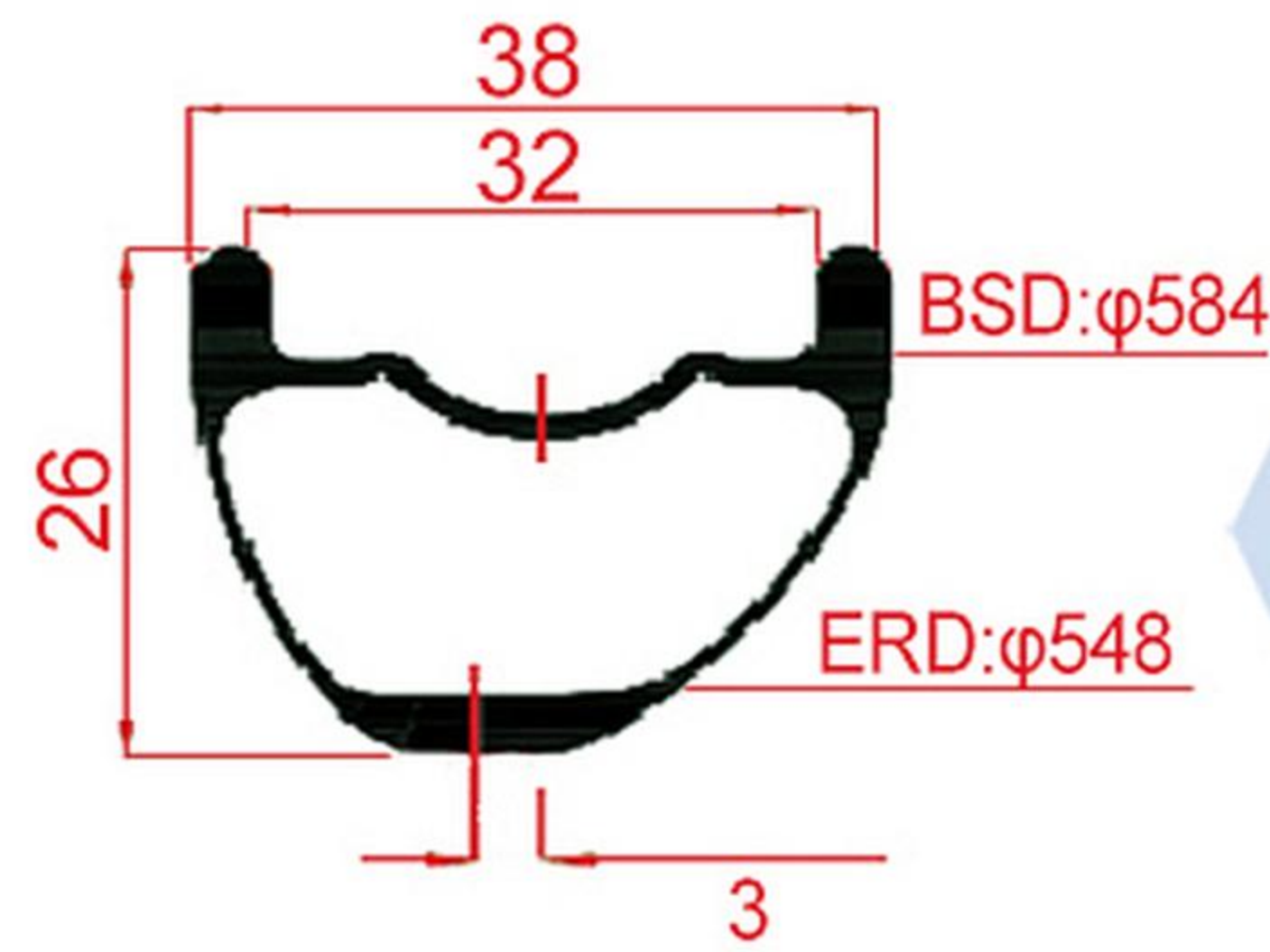

Model: M2638HL-27.5ER
Weight: AM: 375±10g
ERD: 548

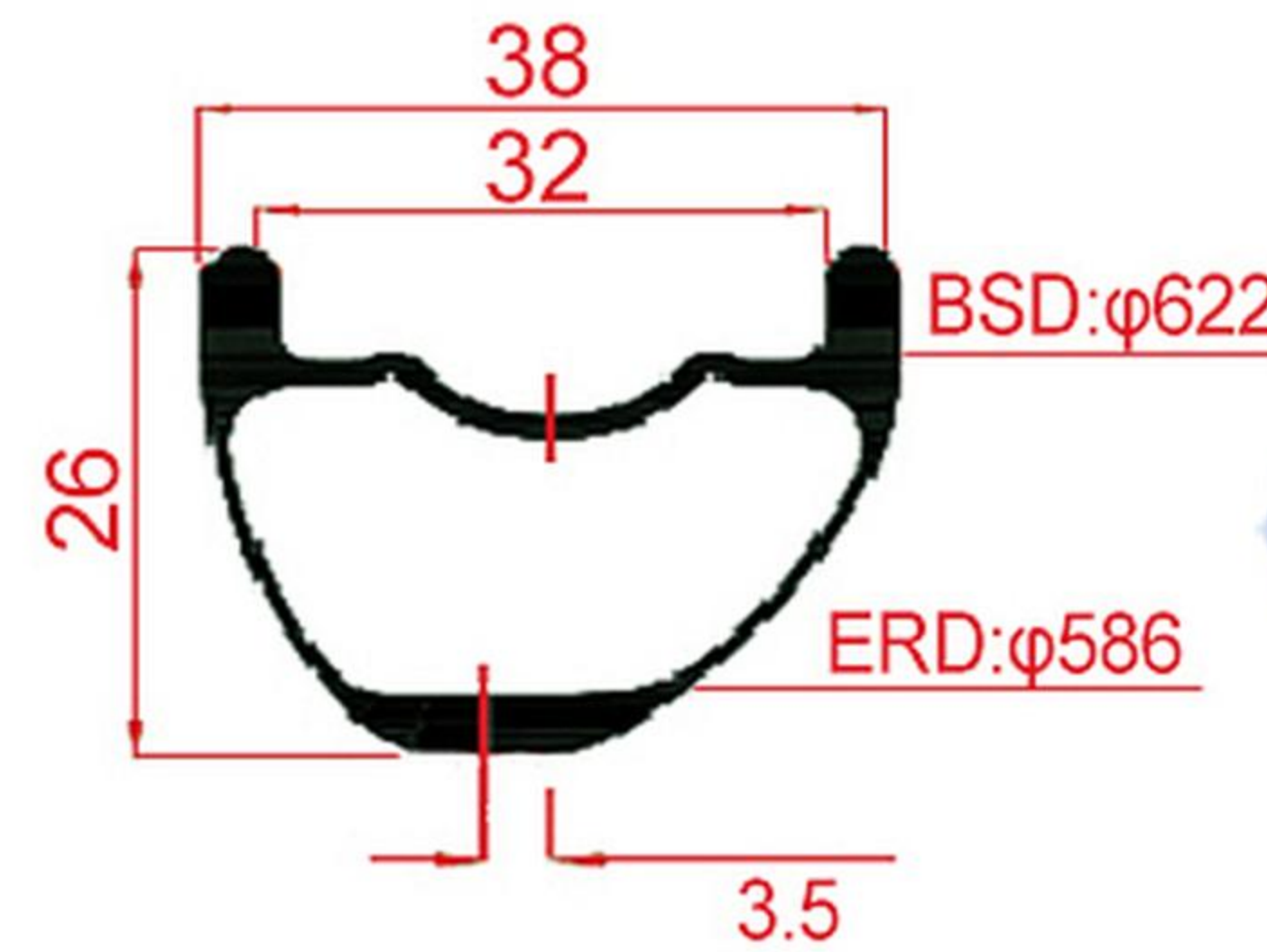

Model: M2638HL-29ER
Weight: AM: 390±10g
ERD: 586

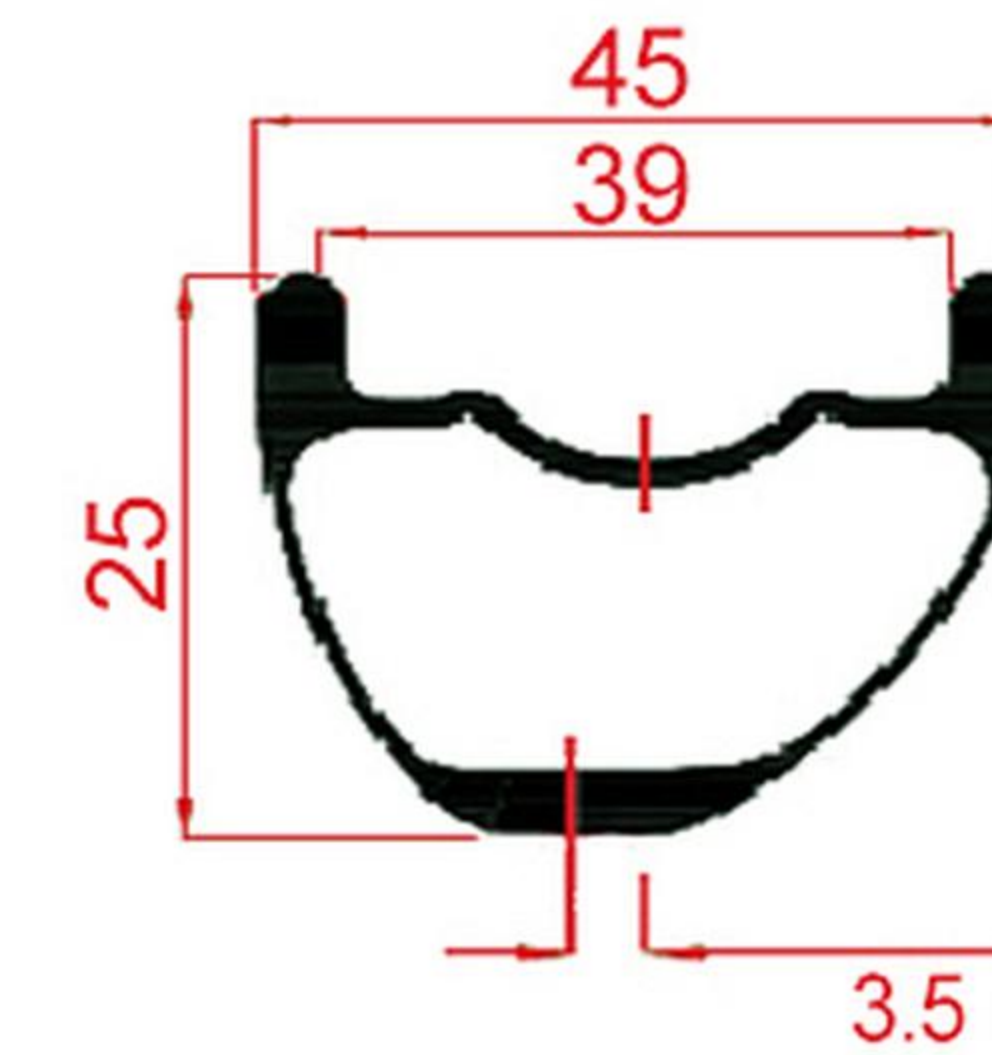

Model: M2545HL-29ER
Weight: AM: 460±15g
DH: 510±15g
ERD: 589

► 29ER Carbon MTB Wave Shape Rims

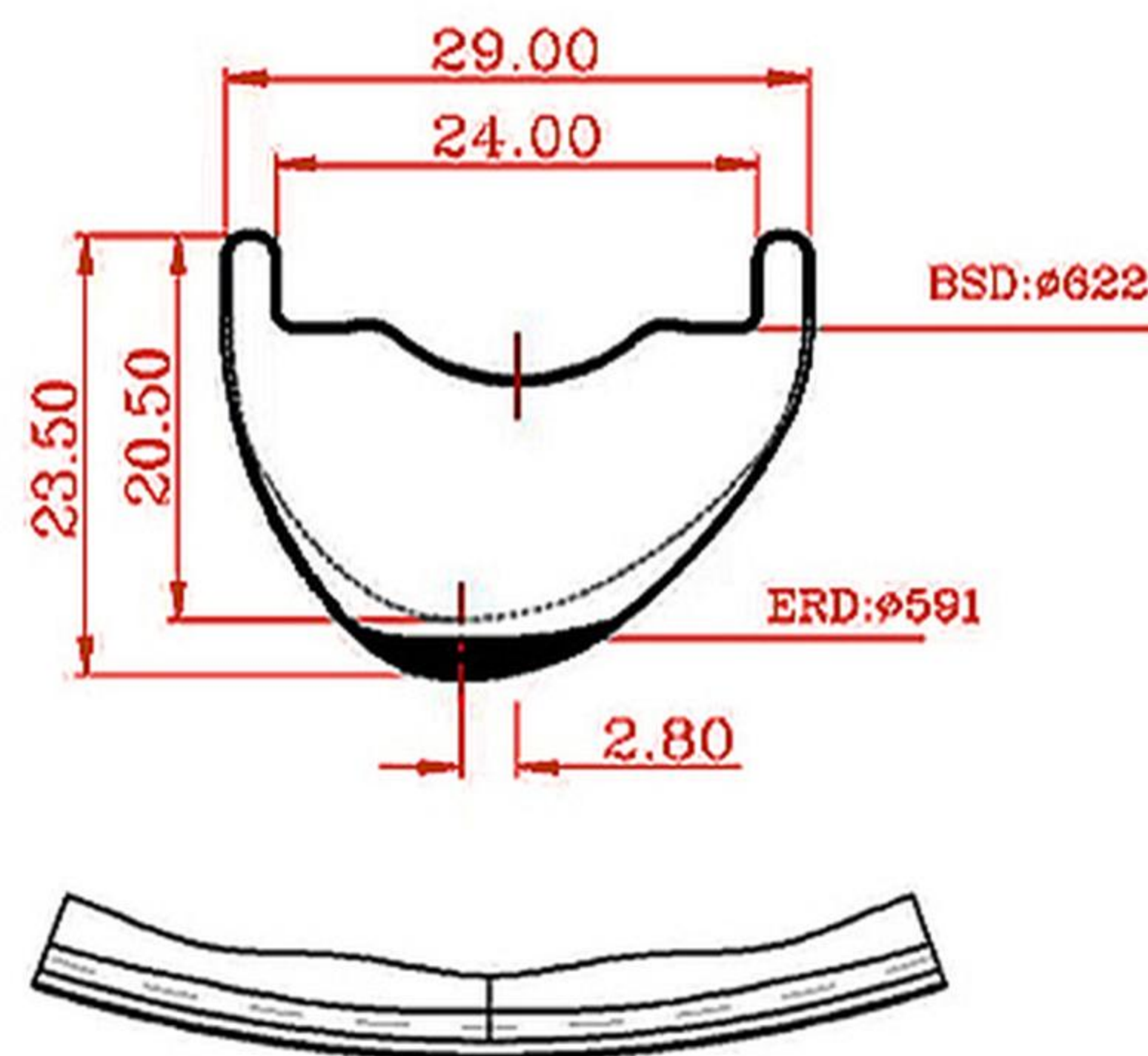

NEW

Model: W2329HL-29ER
Weight:T800: 290±10g
ERD: 591

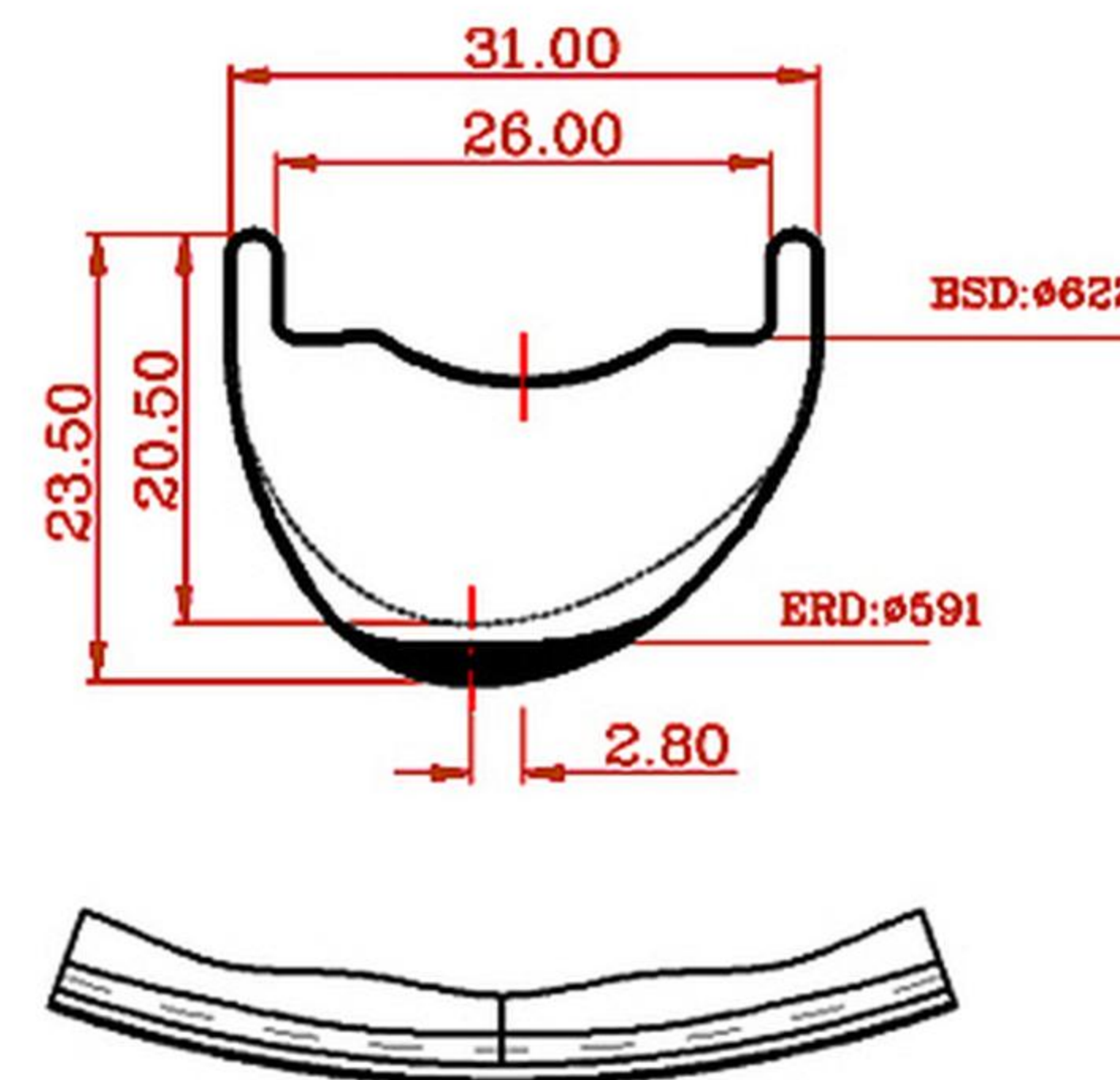

NEW

Model: W2331HL-29ER
Weight:T800: 305±10g
ERD: 591

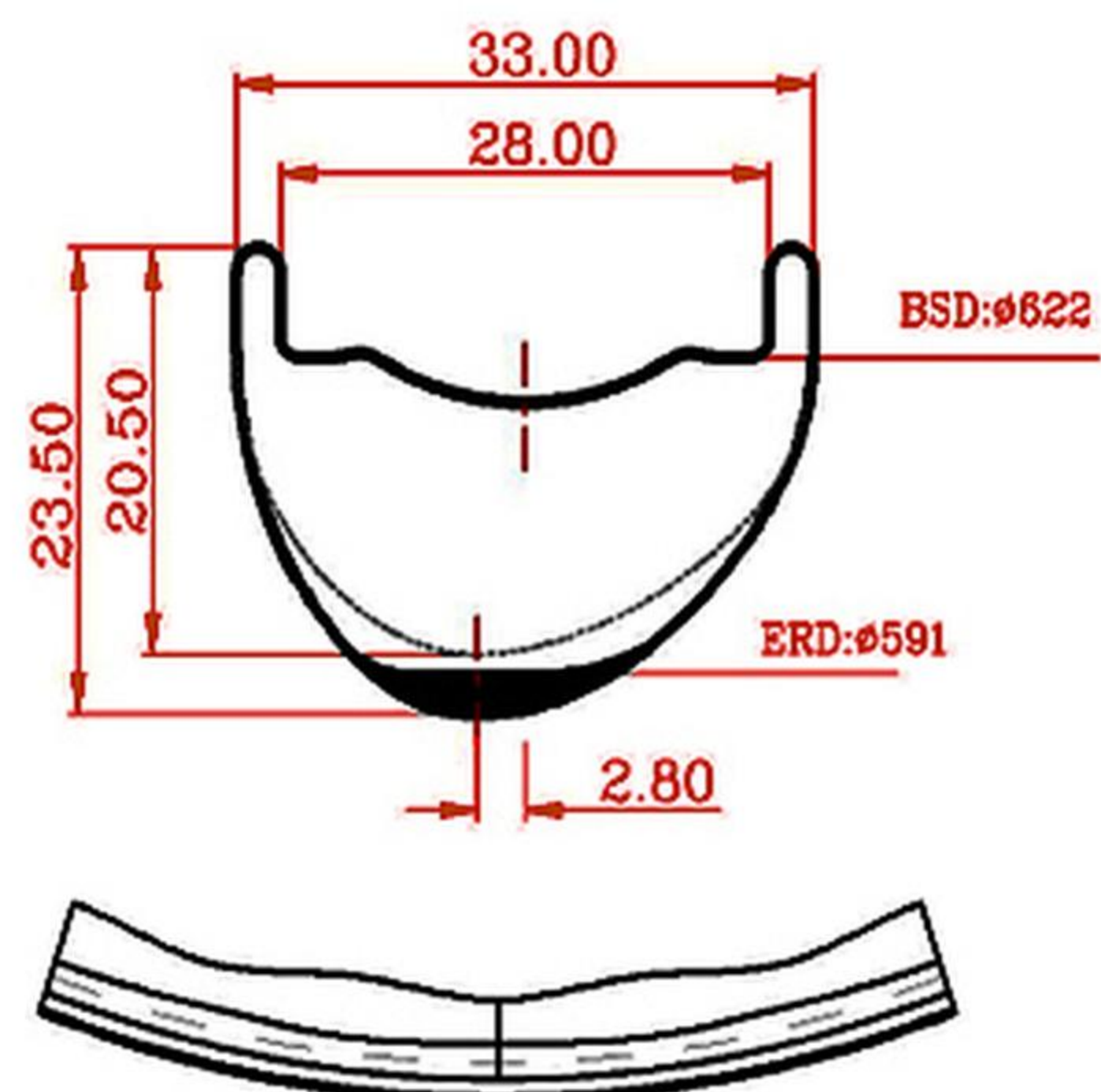

NEW

Model: W2333HL-29ER
Weight:T800: 320±10g
ERD: 591

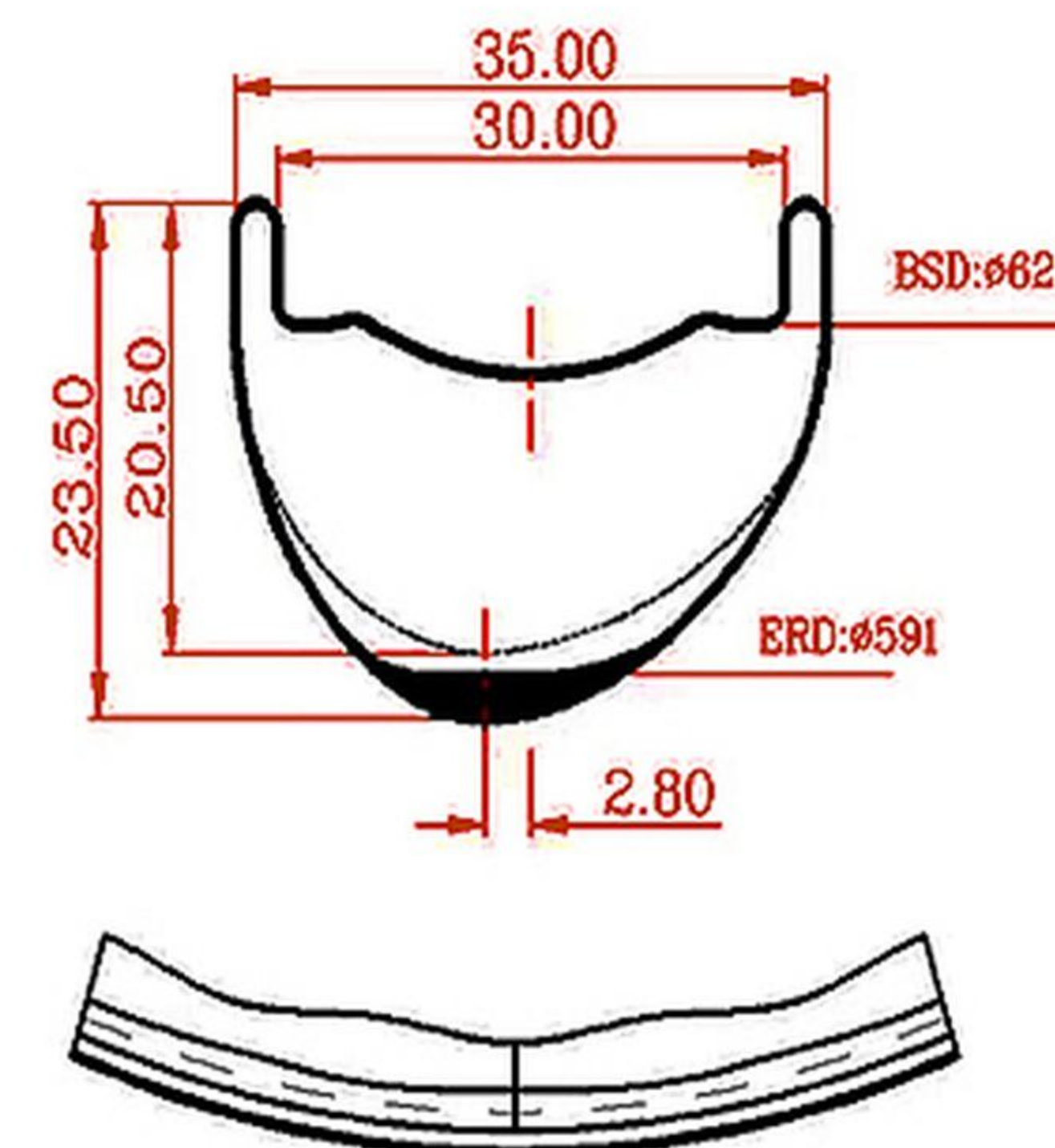

NEW

Model: W2335HL-29ER
Weight:T800: 335±10g
ERD: 591

► Carbon BMX Rims Series

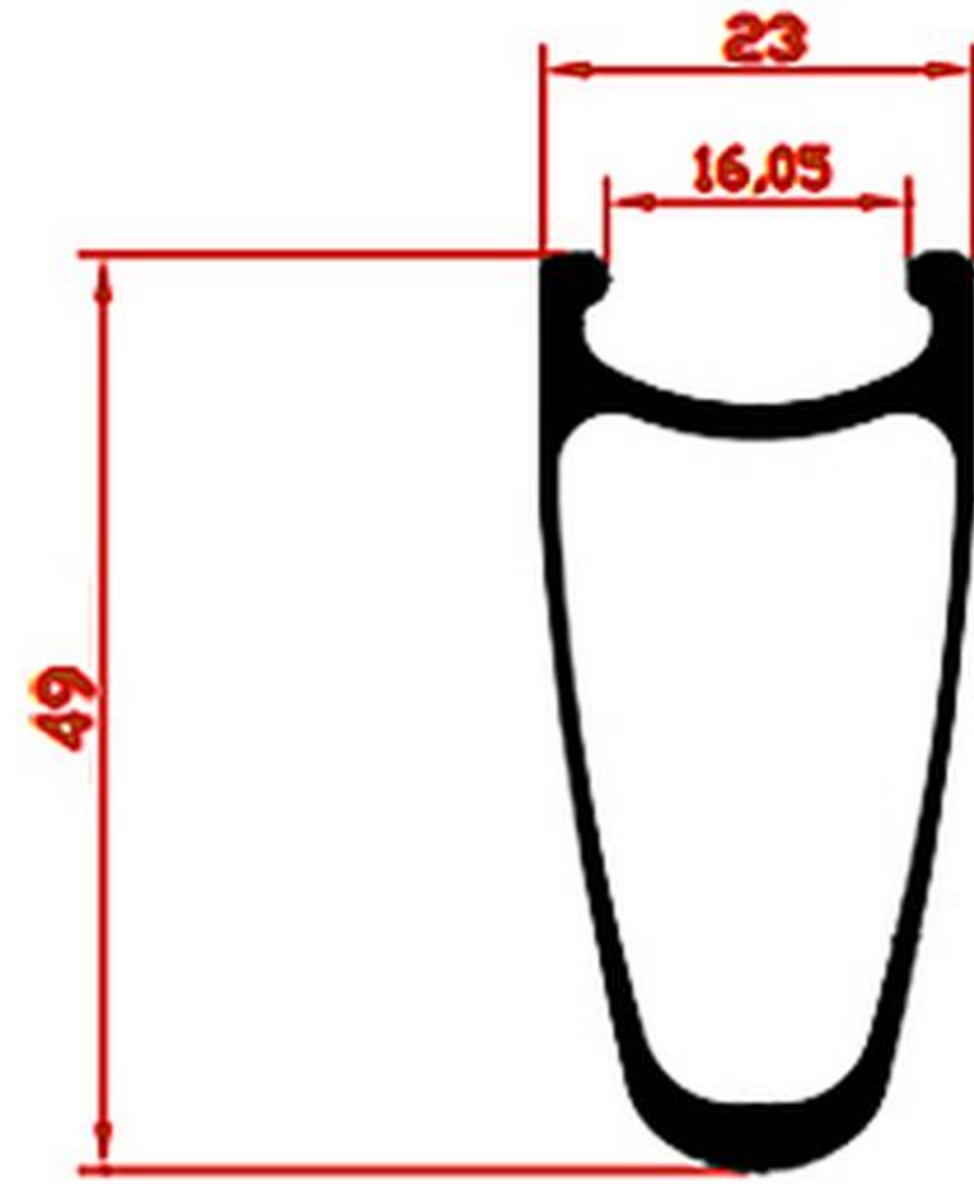

Model: B49C-23-406
Weight: 295 ± 15 g
ERD: 325

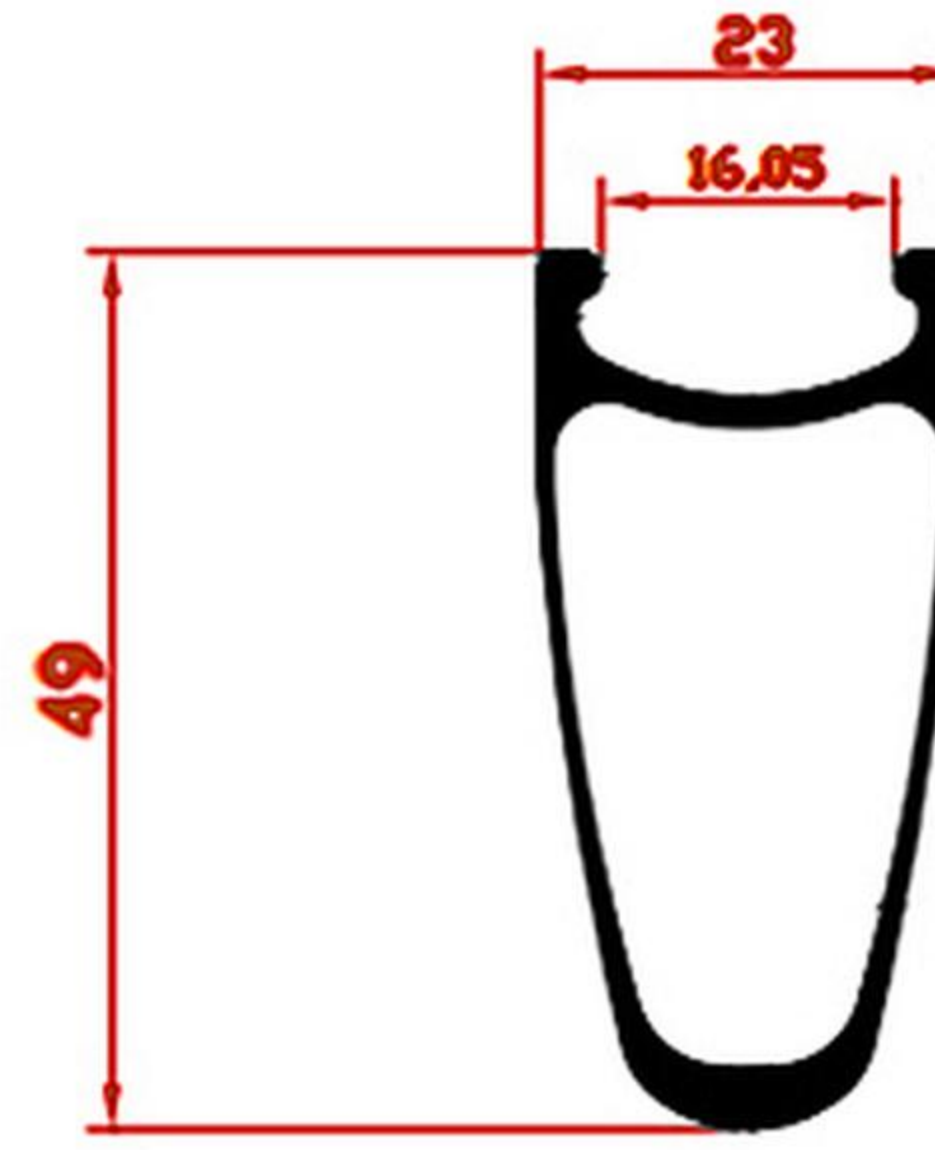

Model: B49C-23-451
Weight: 340 ± 15 g
ERD: 369

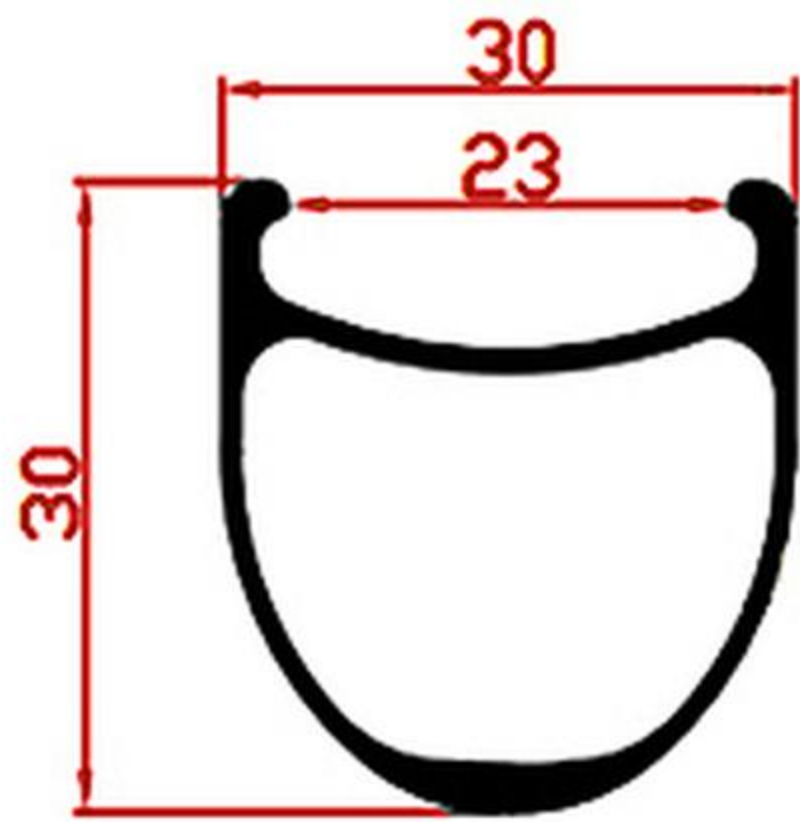

Model: B30C-30-406
Weight: 310 ± 15 g
ERD: 369

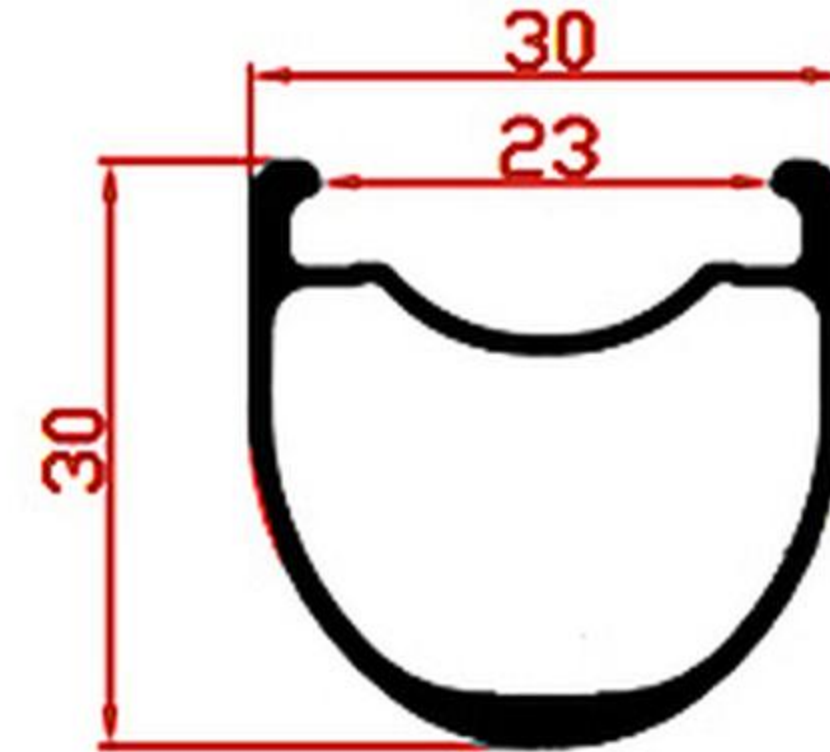

Model: B30TL-30-406
Weight: 310 ± 15 g
ERD: 369

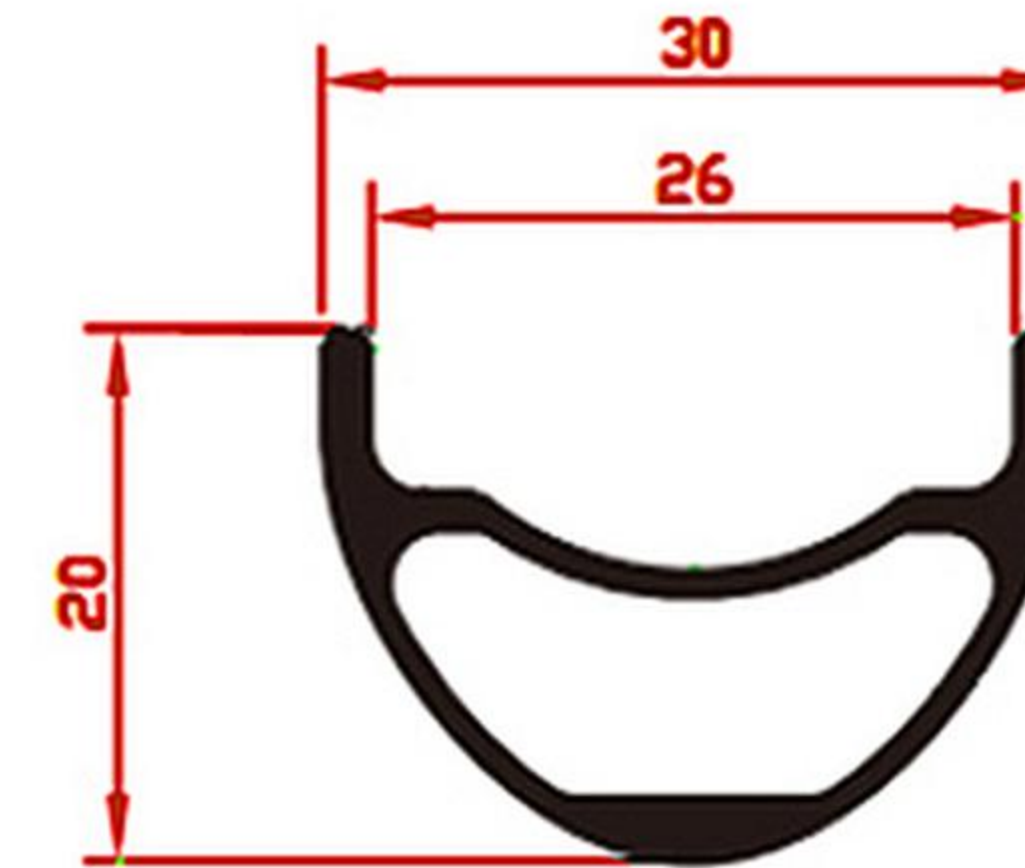

Model: B20HL-30-12 Inch
Weight: 85 ± 5 g

► Carbon Fatbike Rims Series

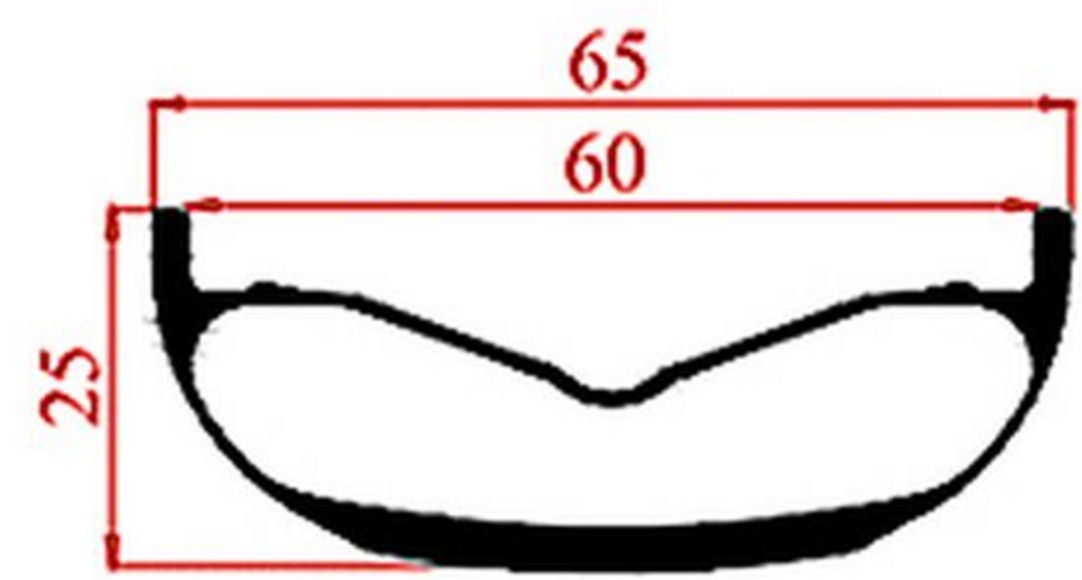

Model: F25HL-65-26ER
Weight: 600±15g
ERD: 533

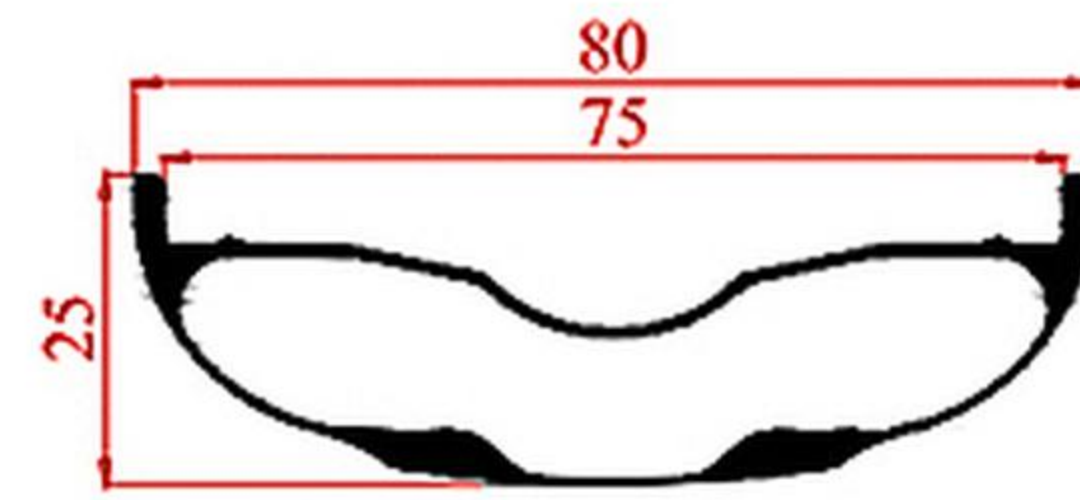

Model: F25HL-80-26ER
Weight: 680±15g
ERD: 533

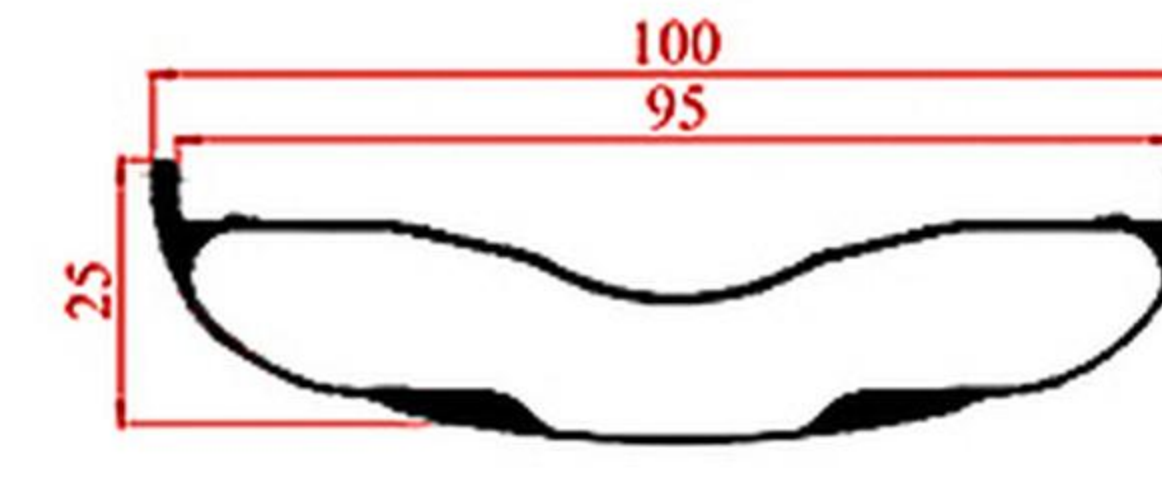

Model: F25HL-100-26ER
Weight: 750±15g
ERD: 533

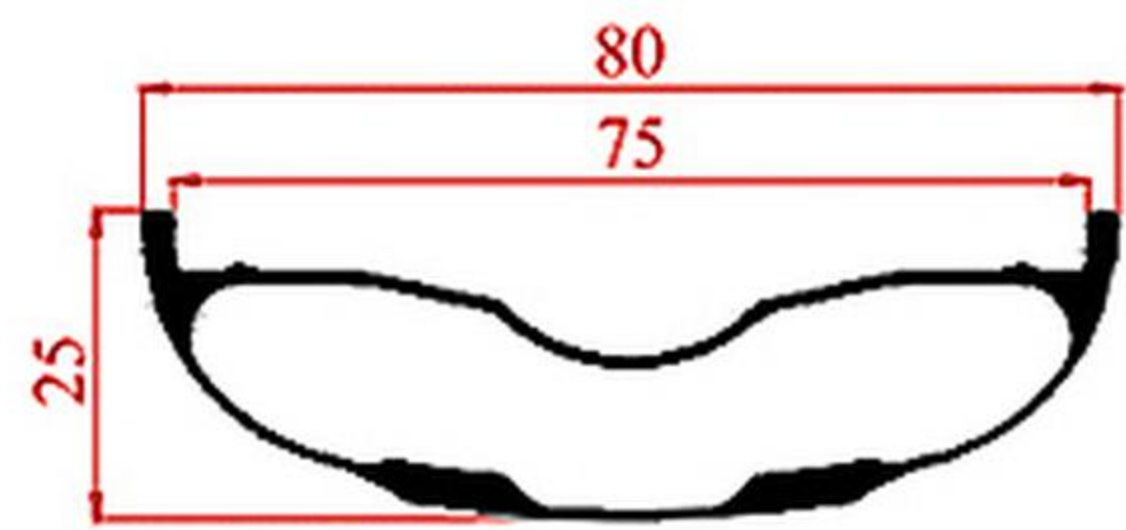

Model: F25HL-80-24ER
Weight: 580±15g
ERD: 476

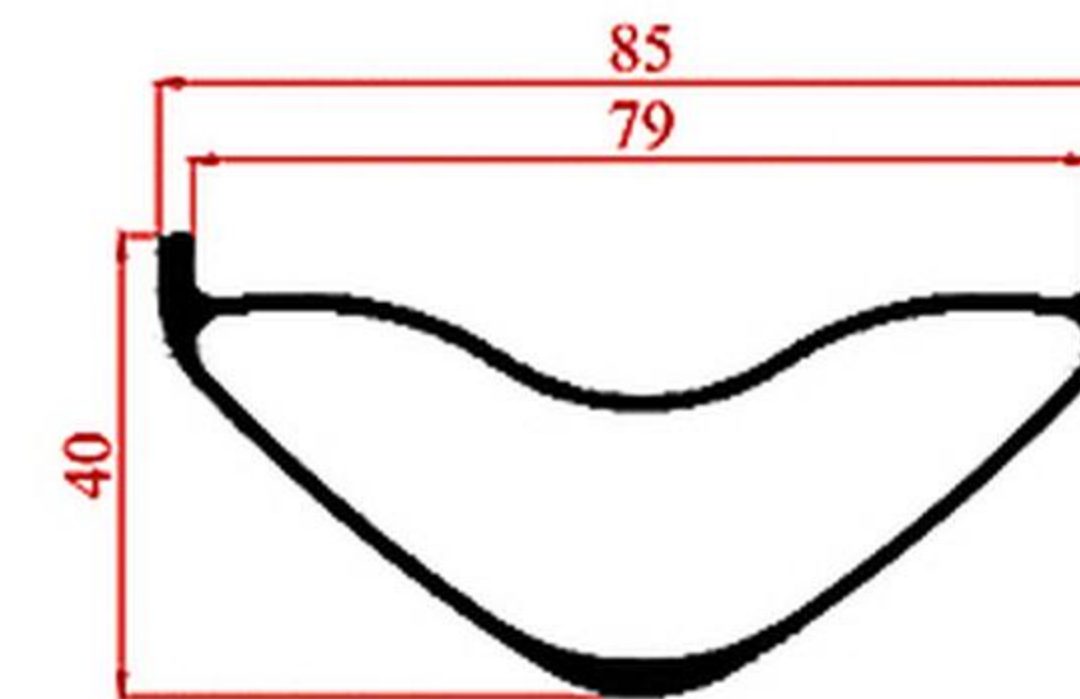

Model: F40HL-85-27ER
Weight: 660±15g
ERD: 522

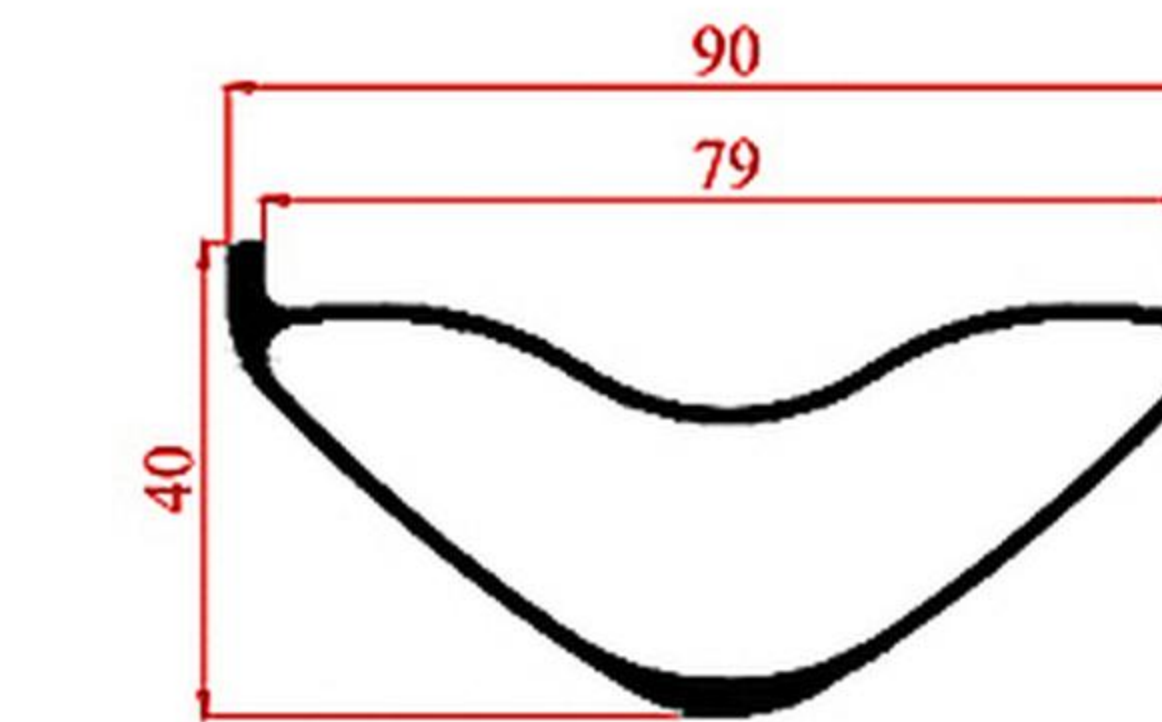

Model: F40HL-90-26ER
Weight: 615±15g
ERD: 497