

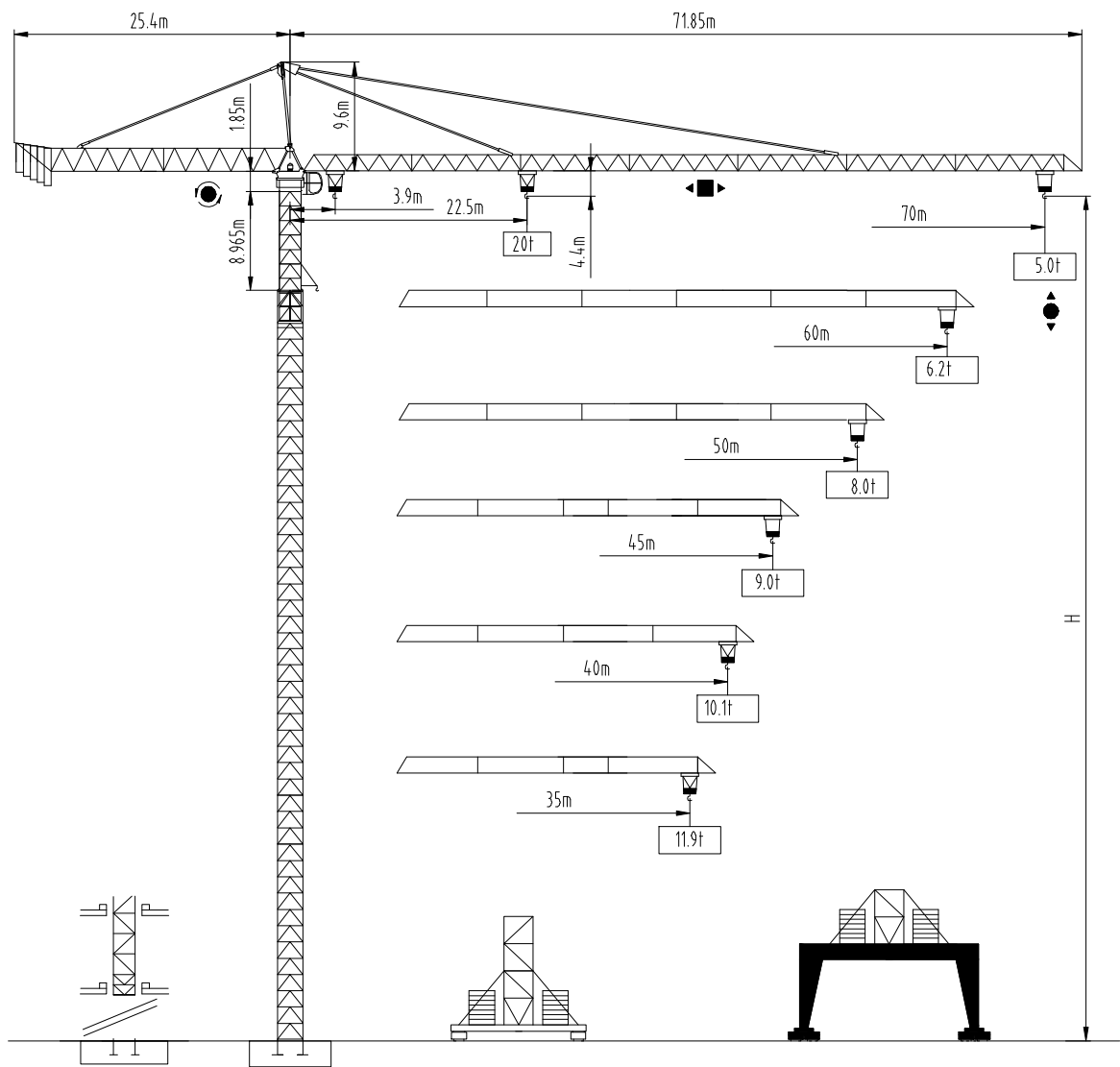

沈阳三洋建筑机械有限公司
SHENYANG SANYO BUILDING MACHINERY CO., LTD

TOWER CRANE **QTZ型450tm**
(K50/50)





塔身截面 Mast \square 2.5m \times 2.5m

35-70m

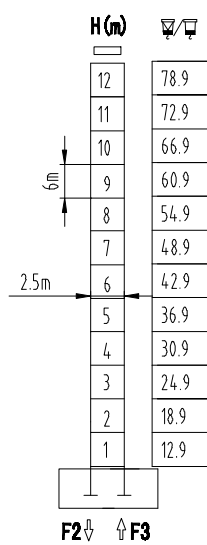

F2 ↓ ↑ F3

F2 • 219t □ 246t

F3 • 120t □ 159t

⊕ 160t

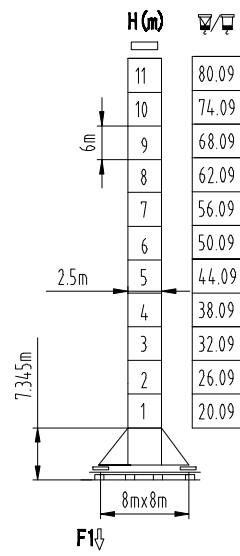

F1 ↓

F1 • 138t □ 166t

⊕ 174t

固定式附着高度 Anchoring height of stationary crane

★ 紧固附着框 Anchorages tightened

△ 放松附着框 Anchorages released

如需达到更高的高度, 请与我们联系. For greater heights, consult us.

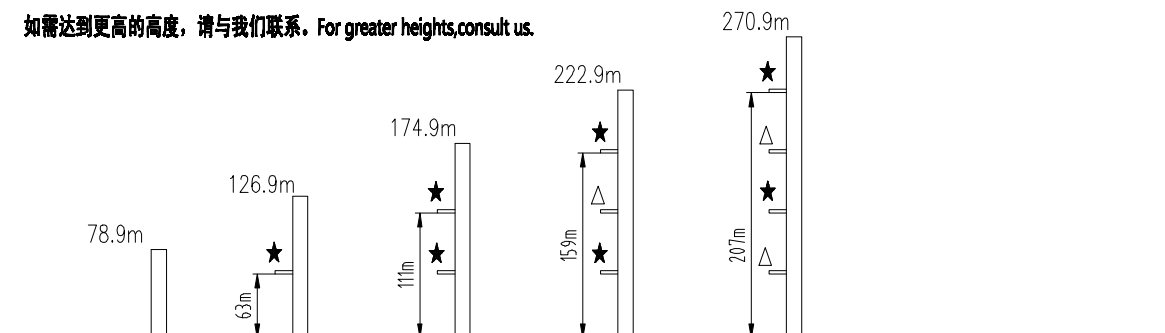

载荷特性 Load diagrams

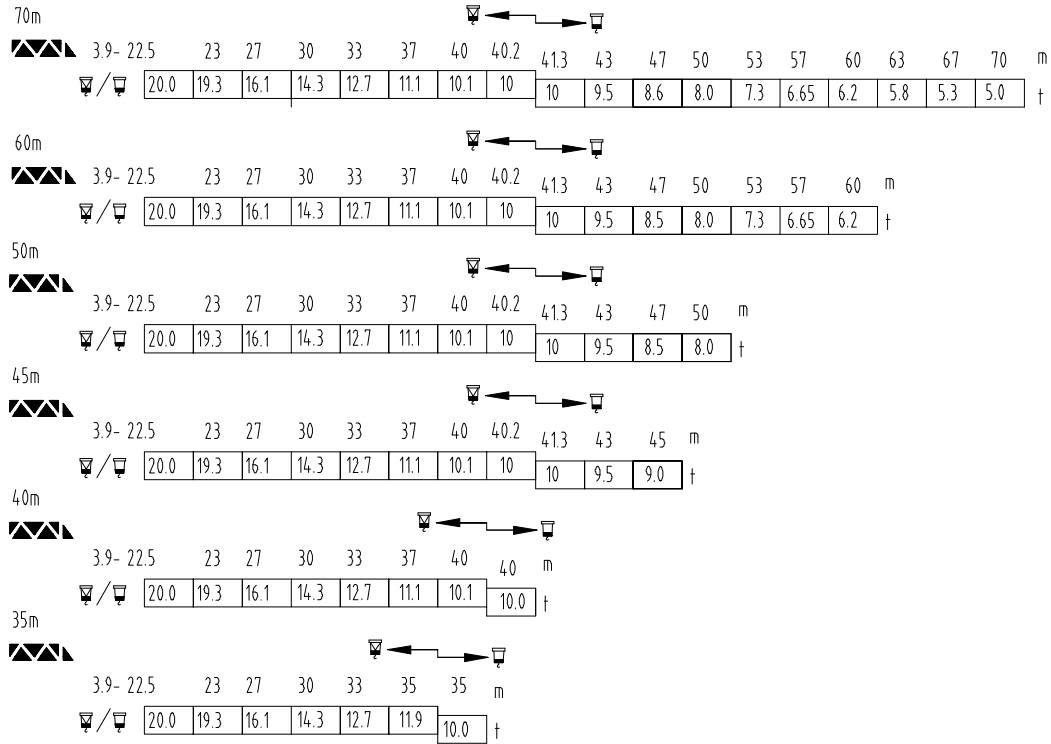

☐/☐ 标准小车可使用 2/4 倍率绳 standard trolley 2/4 fall.

使用四倍率时, 应从二倍率的载荷中减去 0.35 吨

When using ☐ subtract 0.35t from the loads ☐

35m 和 45m 组合为特殊生产, 如需要请与我们联系!

For 35m and 45m jib, consult us.

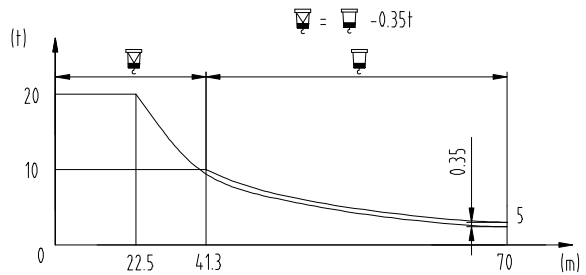



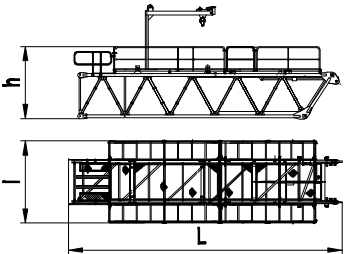
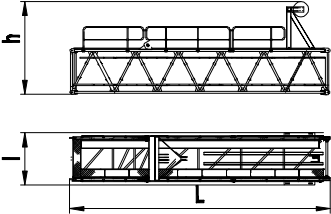
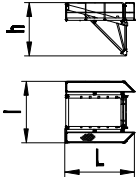
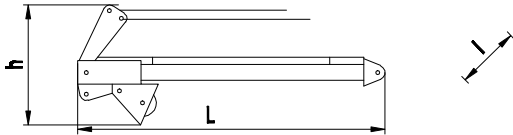
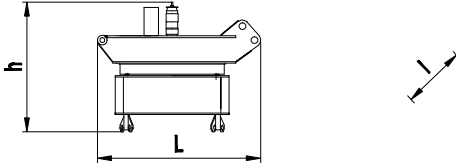
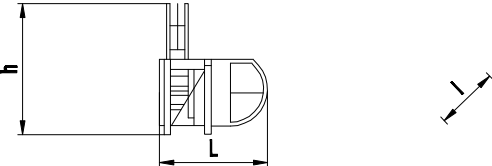
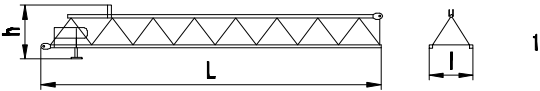

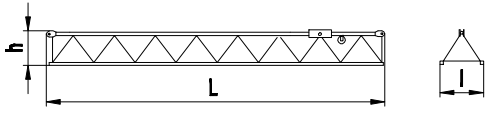
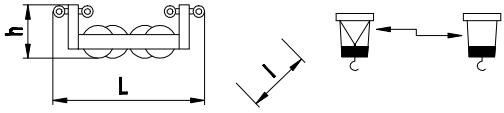
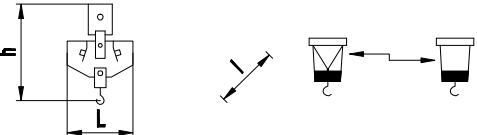
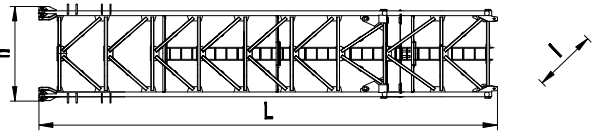
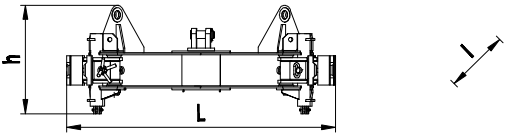
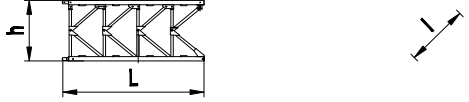

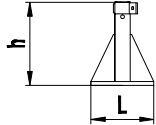
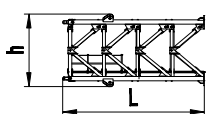
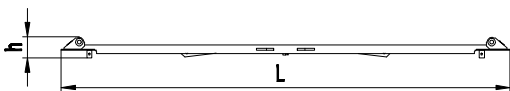
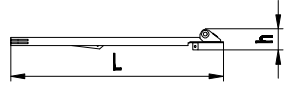
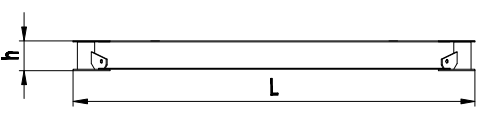
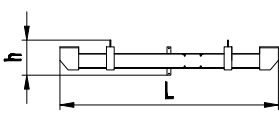
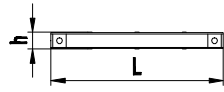
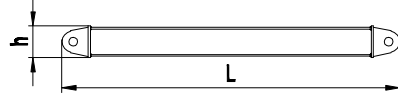

外形尺寸重量表 Dimensions weights

塔机回转部分 Slewing		L(m)	l(m)	h(m)	Kg
平衡臂根节 Counter-jib foot		11.3	3.6	3.2	8118
平衡臂中节 Counter-jib middle section		11.3	2.24	3	8805
平衡臂端节 Counter-jib nose		4	3.5	3.1	1270
塔头 Cat-head		8.0	2.07	2.4	4080
回转机构 Slewing mechanism		2.8	3.1	3	10700
司机室 Cab		2.8	2.4	4.1	1200
起重臂节 Jib section		10.3	2.14	2.08	2766



塔机回转部分 Slewing		L(m)	l(m)	h(m)	Kg	
起重臂节 Jib section		2	10.33	1.9	1.9	2365
		3	10.33	1.9	2	2399
		4	10.33	1.9	1.9	1903
		5	10.33	1.9	2	1962
		6	10.26	1.9	1.85	1642
		7	10.26	1.9	1.85	1526
		变幅小车 Trolley		2.69	2.3	1.25
吊钩滑轮组 Hook assembly		1.5	0.47	3.14	557	
顶升装置 Telescoping equipment		L(m)	l(m)	h(m)	Kg	
内塔节 Inner mast section		12.18	2.51	2.51	11500	
十字梁 Cross-beam		2.34	2.34	1.13	5283	
塔身 Mast		L(m)	l(m)	h(m)	Kg	
标准节 Standard mast		6.285	2.695	2.695	6814	

底部 Base		L(m)	l(m)	h(m)	Kg
固定支脚 Fixing angles		0.8	0.8	1.325	600
底架塔节 Chassis mast section		6.285	3.36	3.36	8110
底架整梁 Total beam		11.924	1.12	0.565	2165
底架半梁 Semi beam		6.38	1.12	0.565	1043
底架横梁 Traverse		8.54	0.63	0.55	1406
底架扁担梁 Carrying-pole beam		4.65	0.36	0.75	620
底架力腿 Strut bar		2.834	0.17	0.18	115
底架撑杆 Brace rod		5.52	0.44	0.37	835

机构特性 Mechanisms specification														Kw	
起升 Hoisting		90LVF	m/min	0-4	0-20	0-40	0-60	0-80	0-2	0-10	0-20	0-30	0-40	600	90
			t	10	10	10	5	2.5	20	20	20	10	5		
变幅 Trolleying		7.5TVF	m/min	0-60										7.5	
回转 Slewing		9SVF	r/min	0-0.6										9x2	
		14.5SVT												14.5Nm x 2	
行走 Travelling		5.2TRVF	m/min	0-15										5.2x6	

 电源 Power Supply	380V 50Hz / 440V 60Hz
KVA 供电容量 Necessary Electric Power	200KVA

平衡臂配重
Counter-jib ballast

		▲ (t)
70m	25.4m	25
60m	25.4m	21.6
50m	25.4m	18.2
45m	25.4m	14.9
40m	25.4m	13.2
35m	25.4m	11.6

可变换的其它安装方式
Mounting possibilities

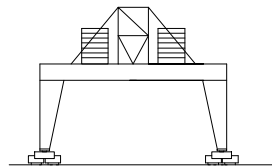
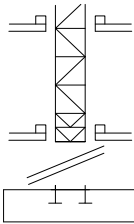

 同我们协商
Consult us

F 反力 • 工作状态 In service ⊕ 自重 不带载荷及配重，最大臂长及标准高度时的自重
Reactions ▪ 非工作状态 Out of service Self-load Without load and counter-weight with longest jib and standard height