

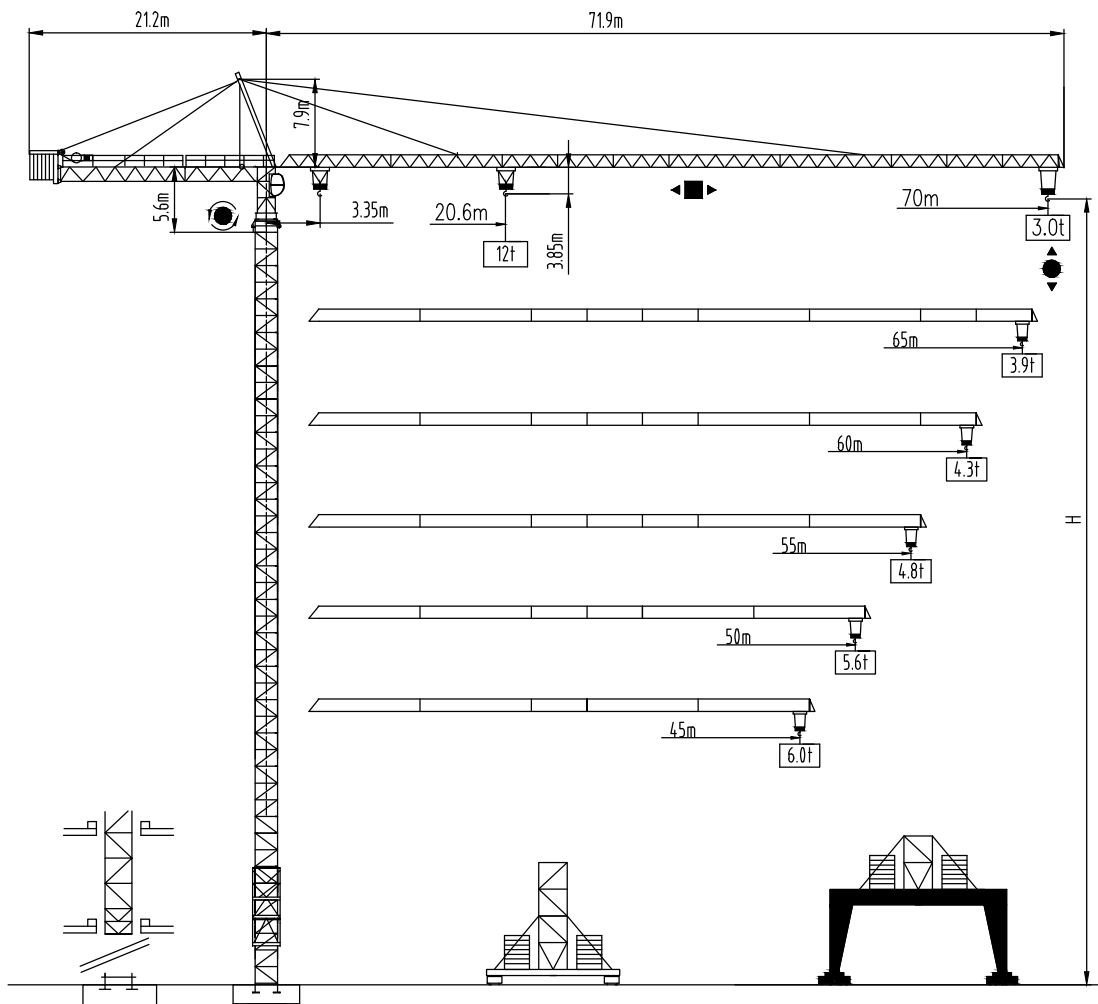

沈阳三洋建筑机械有限公司
SHENYANG SANYO BUILDING MACHINERY CO., LTD

TOWER CRANE QTZ型250tm
(K30/30)





塔身截面 Mast □ 2mx2m

▲▲▲ 45-70m

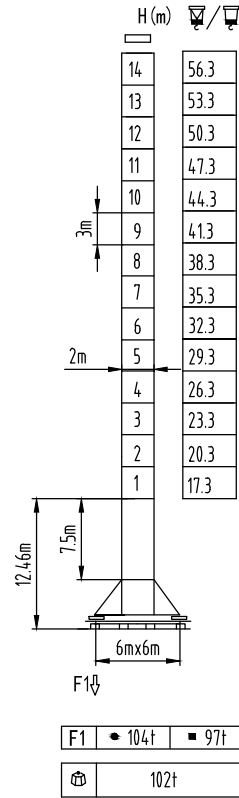
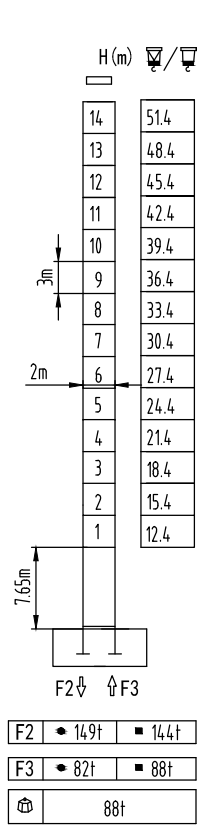

固定式附着高度 Anchoring height of stationary crane

★ 紧固附着框 Anchorages tightened

△ 放松附着框 Anchorages released

如需达到更高的高度, 请与我们联系。For greater heights, consult us.

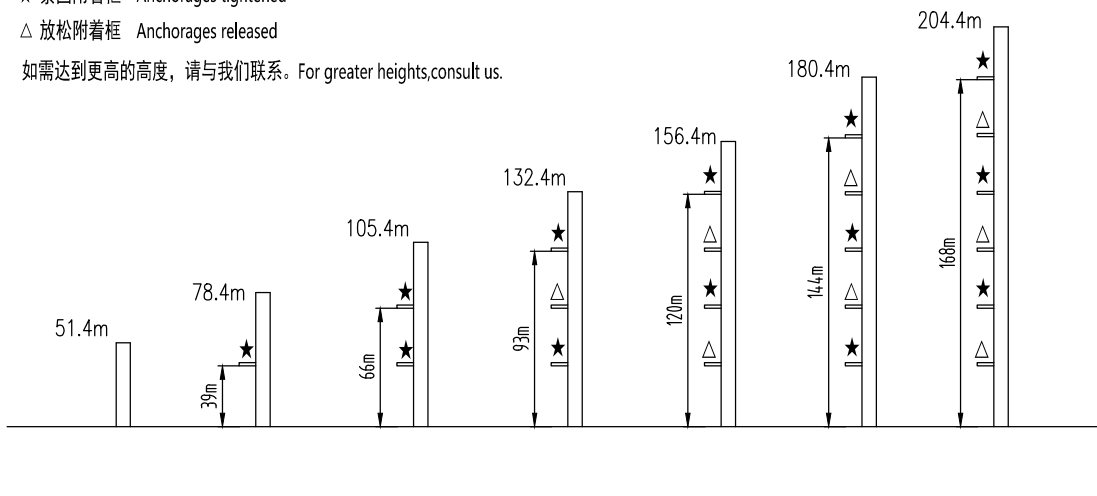

载荷特性 Load diagrams

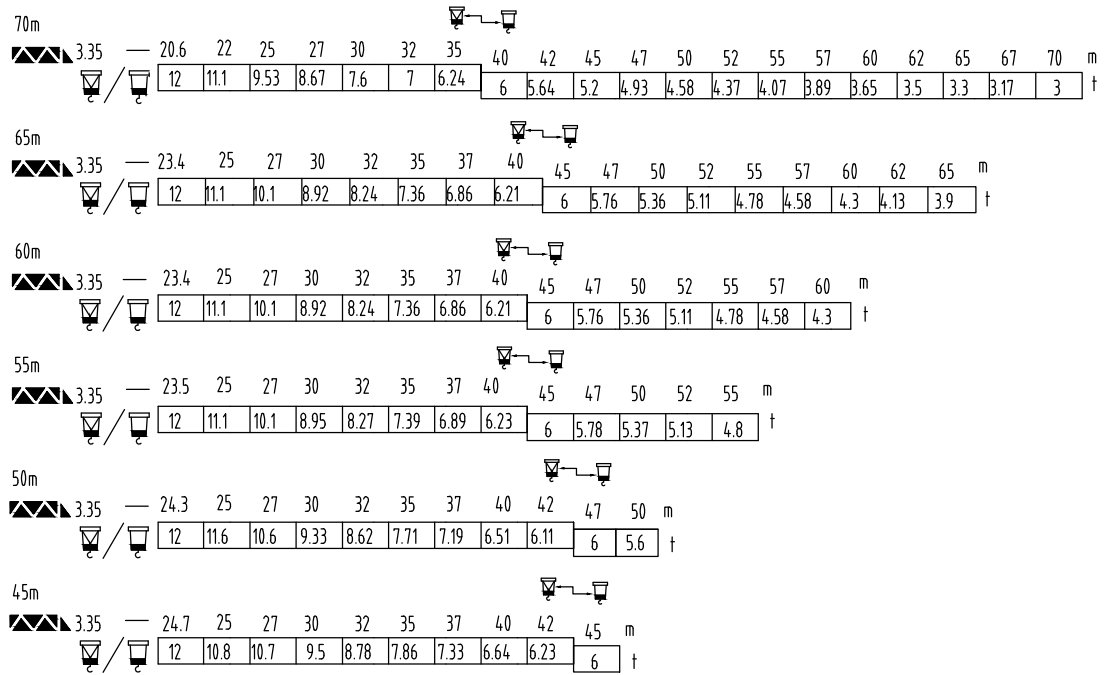

标准小车可使用 2/4 倍率绳 standard trolley 2/4 fall.

使用四倍率时, 应从二倍率的载荷中减去 0.2 吨

When using 2/4 fall subtract 0.2t from the loads

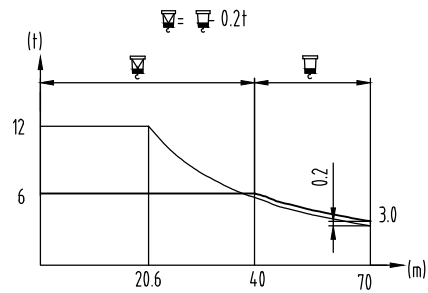

内爬塔机 Climbing crane

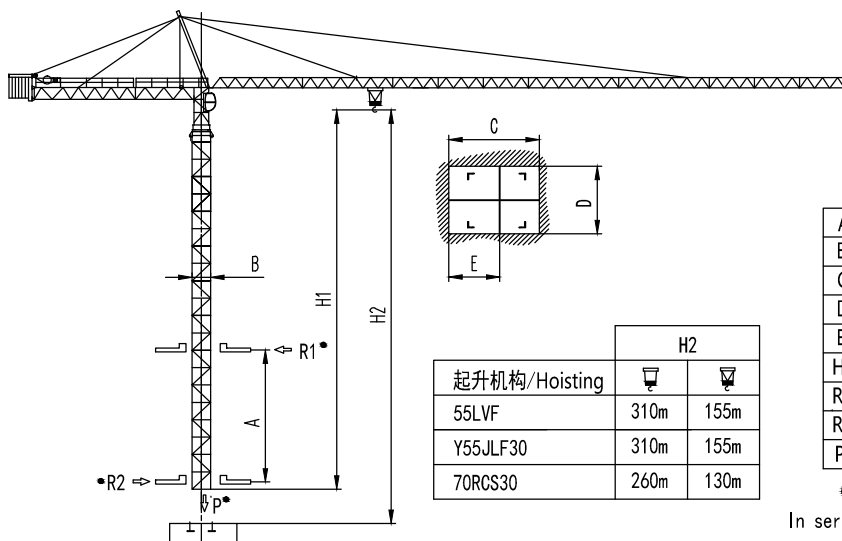

A	12m-19m
B	2m
C	2.58m
D	2.17m
E	1.495m
H1	45.6m
R1	25.4t-27.3t
R2	22.3t-23.7t
P	110t

工作状态无系数
In service without coefficient

外形尺寸重量表 Dimensions weights

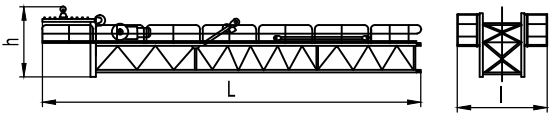
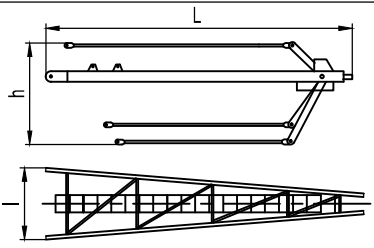
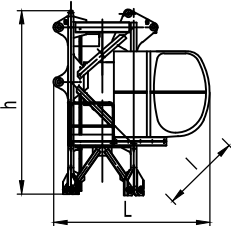
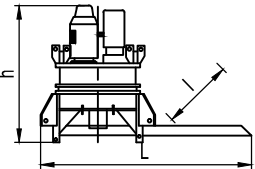
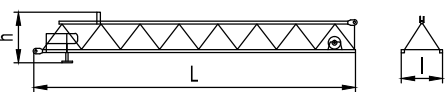
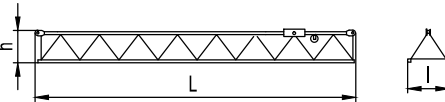
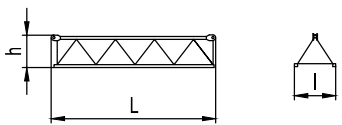
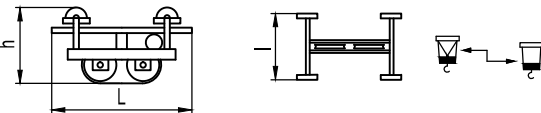
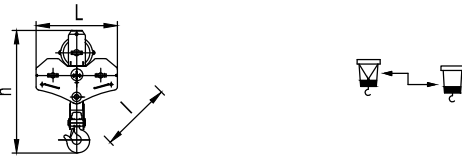
塔机回转部分 Slewing		L(m)	l(m)	h(m)	Kg	
平衡臂 Counter-jib		20.5	3.10	4.10	11330	
撑杆 Strut		8.80	1.60	1.40	2600	
驾驶室节 Cab		3.65	3.20	4.30	6028	
回转总成 Pivot		4.25	2.40	2.40	8300	
起重臂节 Jib section		10.45	1.75	1.60	2472	
起重臂节 Jib section		2	10.35	1.60	1.30	2227
		6	10.35	1.60	1.30	1820
		7	10.35	1.60	1.30	1954
起重臂节 Jib section		3	5.33	1.60	1.30	1052
		4	5.33	1.60	1.30	1052
		5	5.33	1.60	1.30	1052
		8	5.20	1.60	1.20	585
		9	5.20	1.60	1.20	447
10	5.20	1.60	1.20	422		
变幅小车 Trolley		1.95	1.90	1.02	440	
吊钩滑轮组 Hook assembly		1.35	0.395	2.20	445	

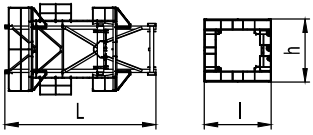
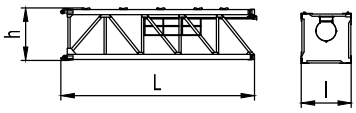
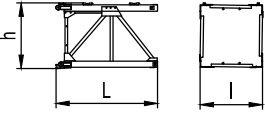
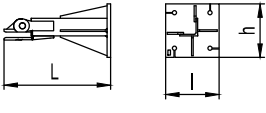
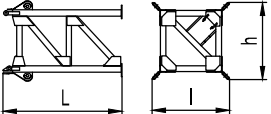
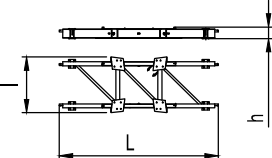
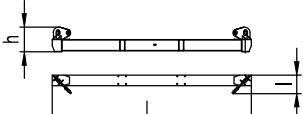
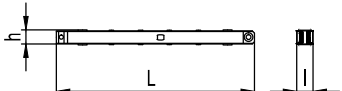
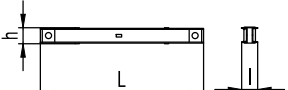
顶升装置 Telescoping equipment		L(m)	l(m)	h(m)	Kg
顶升套架 Telescopic cage		7.26	4.3	4.05	4863
塔身部分 Mast		L(m)	l(m)	h(m)	Kg
基础节 Basic mast		7.76	2.0	2.1	4320
标准节 Standard mast		3.26	2.2	2.2	1820
底部 Base		L(m)	l(m)	h(m)	Kg
固定支脚 Fixing angles		1.2	0.6	0.6	295
底架塔节 Chassis-mast		3.82	2.48	2.48	3260
底架纵梁 Side member		7.14	2.51	0.52	2009
底架横梁 Traverse		6.38	0.58	0.8	1410
底架撑杆 Brace rod		4.45	0.35	0.32	710
底架水平杆 Horizontal member		2.44	0.22	0.24	151

机构特性 Mechanisms specification														Kw	
起升 Hoisting		70RCS30	m/min	0-40		0-80			0-20		0-40		533	51.5	
		t		6		3			12		6				
回转 Slewing		Y55JLF30	m/min	0-4	0-20	0-40	0-60	0-80	0-2	0-10	0-20	0-30	0-40	630	55
		55LVF	m/min	0-4	0-20	0-40	0-60	0-80	0-2	0-10	0-20	0-30	0-40	630	55
变幅 Trolleying		4TVF	m/min	0-55										4	
行走 Travelling		5.2TRVF	m/min	0-15										5.2x4	
电源 Power Supply		380V 50Hz / 440V 60Hz													
KVA 供电容量 Necessary Electric Power		115KVA													

平衡臂配重
Counter-jib ballast

			(t) 70RCS30	(t) Y55JLF30	(t) 55LVF
70m		21.2m	23.6	22.8	21.8
65m		21.2m	23.2	22.5	21.4
60m		21.2m	19.6	19.0	17.8
55m		21.2m	18.4	17.6	16.6
50m		21.2m	17.0	16.2	15.2
45m		21.2m	14.4	13.8	12.6

可变换的其它安装方式
Mounting possibilities

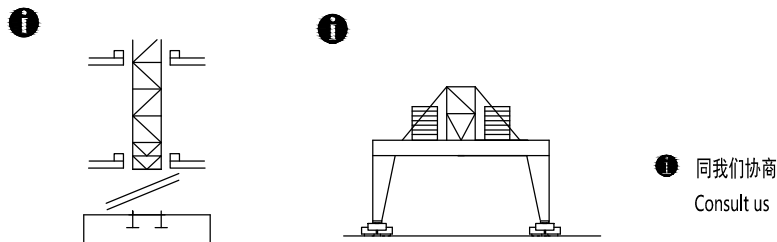

F 反力 Reactions	<ul style="list-style-type: none"> ● 工作状态 In service ■ 非工作状态 Out of service 	⊕ 自重 Self-load	不带载荷及配重, 最大臂长及标准高度时的自重。 Without load and counter-weight with longest jib and standard height
-------------------	-----------------------------------------------------------------------------------------------------	-------------------	-------------------------------------------------------------------------------------------------