

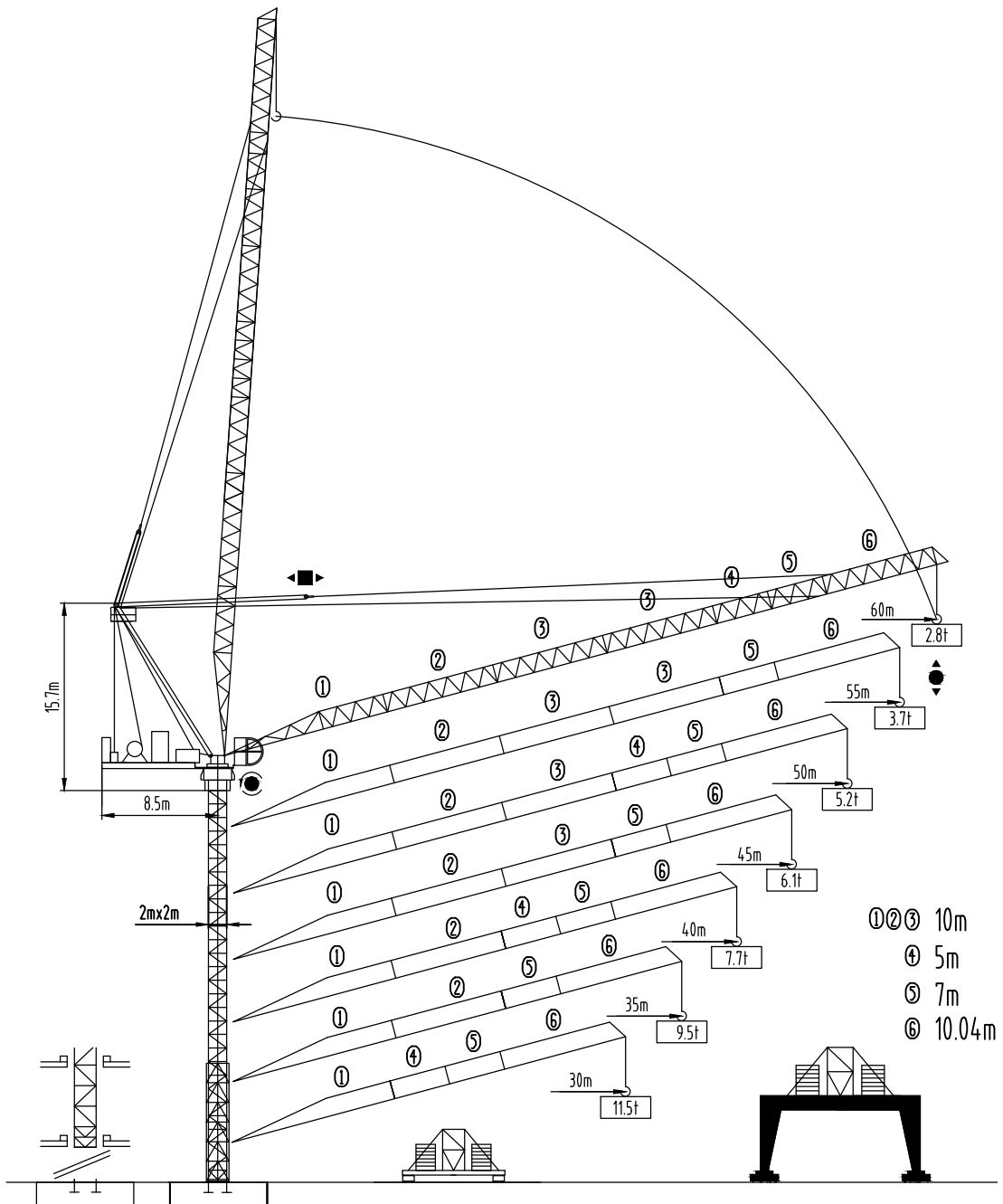

沈阳三洋建筑机械有限公司
SHENYANG SANYO BUILDING MACHINERY CO., LTD

Max Load: 18Ton
Jib: 60M
Tip Load: 2.8Ton
Free Standing: 47.7M

TOWER CRANE QTD 260t · m
(HL45/28)





塔身截面L69R Mast 2mx2m

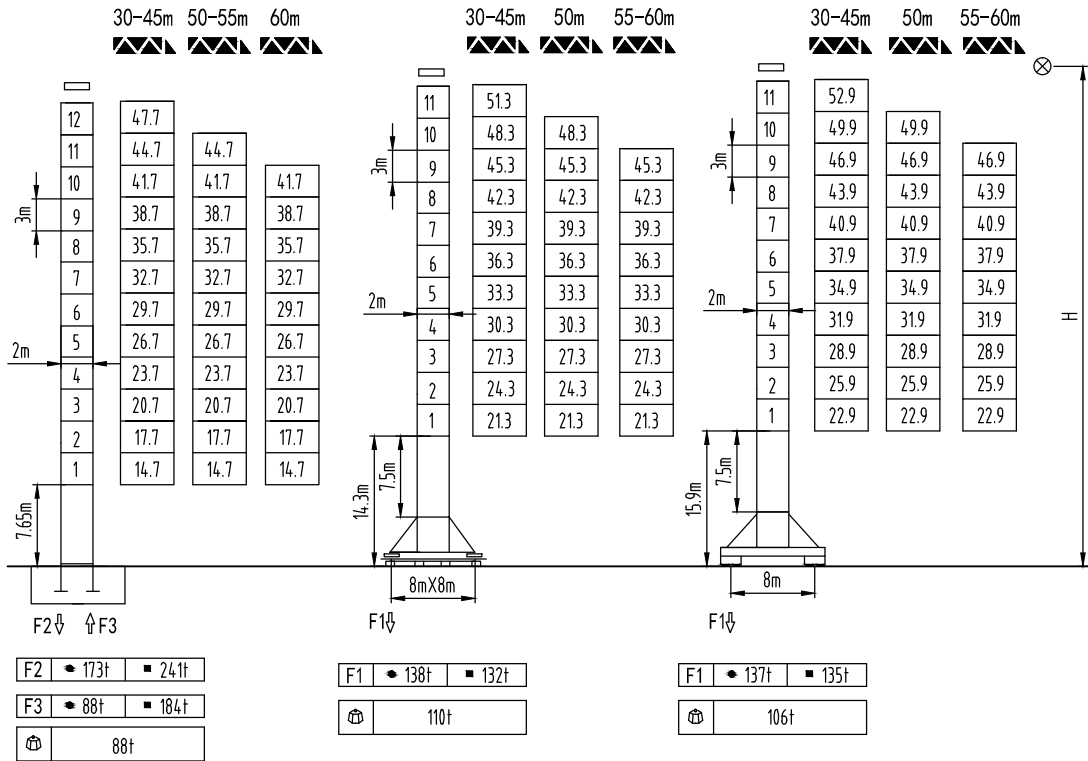

固定式附着高度 Anchoring height of stationary crane

★ 紧固附着框 Anchorages tightened

△ 放松附着框 Anchorages released

如需达到更高的高度, 请与我们联系。For greater heights, consult us.

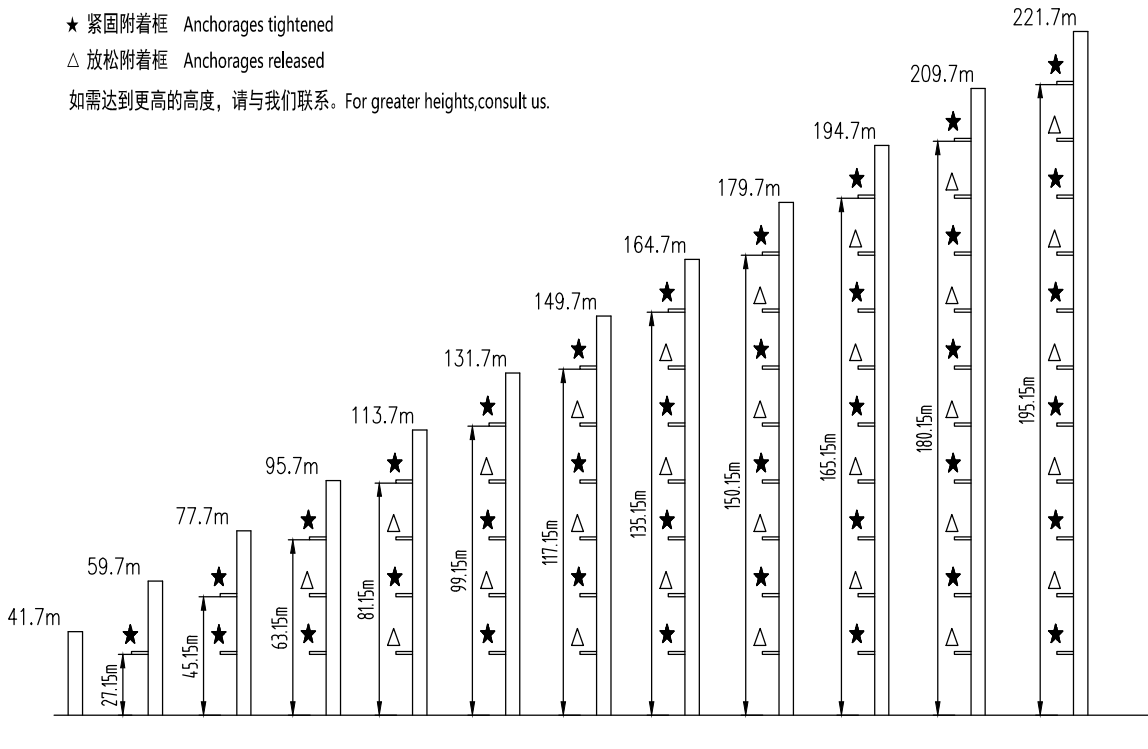

载荷特性 Load diagrams

60m	4.5	35.5	37	40	42	45	47	50	52	55	57	60	m									
	9	8	6.9	6.3	5.5	5	4.3	3.9	3.3	3.1	2.8	t										
55m	4.2	19.5	22.4	25	27	28	30	32	35	35.7	36.5	37.5	40	42	45	47	50	52	55	m		
	18	16	13.6	12.1	11.4	10.4	9.6	8.7	8.5	8.1	7.5	6.7	6.1	5.2	4.7	4.3	3.9	3.3	t			
												9	8.6	8.0	7.2	6.6	5.7	5.2	4.7	4.3	3.7	t
50m	3.8	19.5	22.5	25	27	28	30	32	36	37	38.1	40	42	45	47	50	m					
	18	16	13.7	12.2	11.6	10.6	9.8	8.5	8.0	7.4	6.9	6.3	5.5	5.2	4.8	t						
												9	8.5	7.9	7.4	6.8	5.9	5.6	5.2	t		
45m	3.5	19.6	22.7	25	27	28	30	32	35	36.3	38.5	40	42	45	m							
	18	16	13.9	12.3	11.8	10.8	10.1	9.1	8.5	7.5	7.1	6.6	5.7	t								
												9	8	7.5	7	6.1	t					
40m	3.1	19.7	22.8	25	27	28	30	32	35	36.7	39.2	40	m									
	18	16	14	12.5	12.1	11.1	10.3	9.3	8.5	7.5	7.2	t										
												9	8	7.7	t							
35m	2.8	19.9	23.1	25	27	28	30	32	35	m												
	18	16	14.3	12.8	12.3	11.3	10.5	9.5	t													
									9	t												
30m	2.4	20.2	23.4	25	27	28	30	m														
	18	16	14.6	13	12.5	11.5	t															
							9	t														

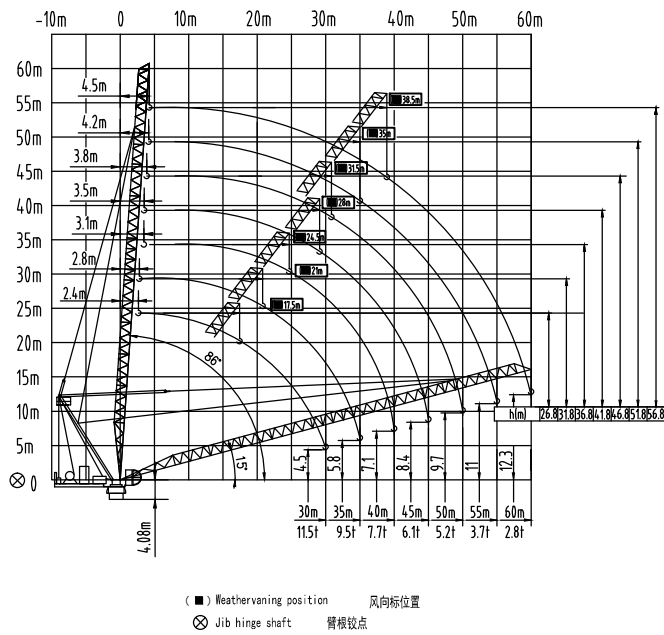

内爬塔机 Climbing crane

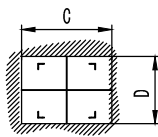
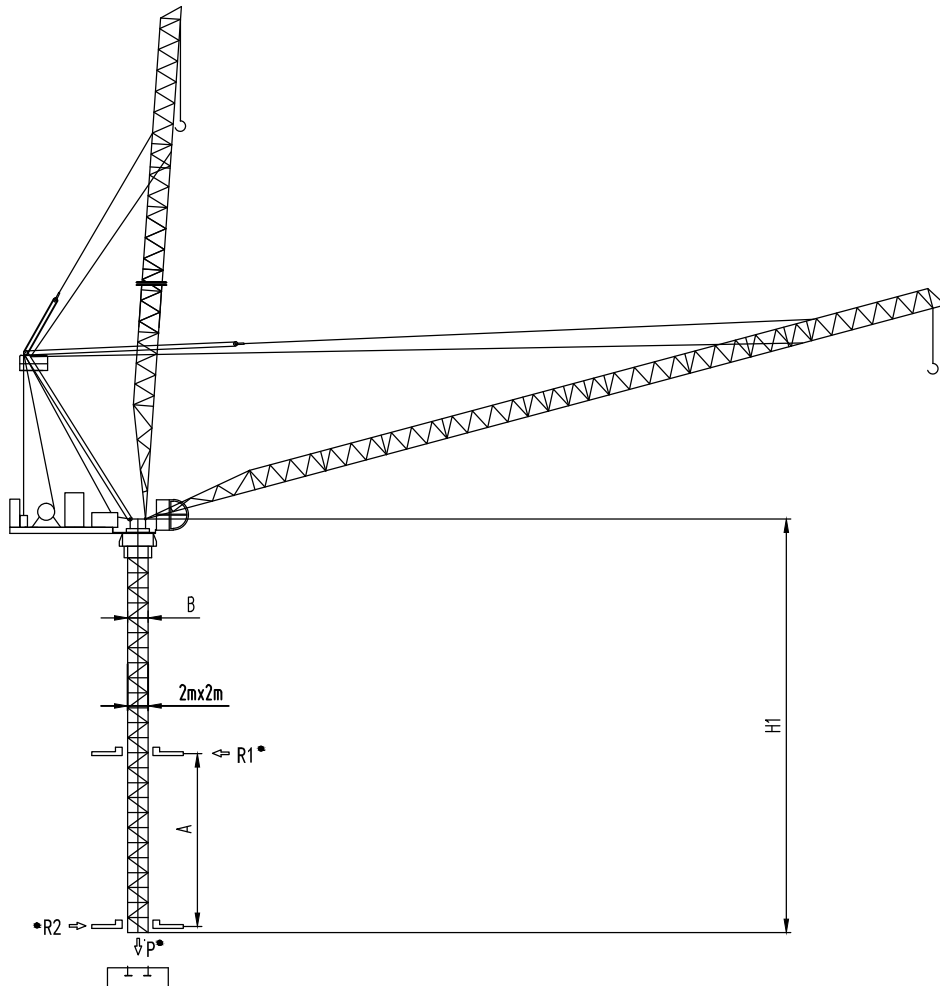

	L69R
A	12m-15m
B	2.0m
C	3.0m
D	2.2m
H1	37m
R1*	43t
R2*	38t
P*	145t

● 工作状态无系数
In service without coefficient

外形尺寸重量表 Dimensions weights

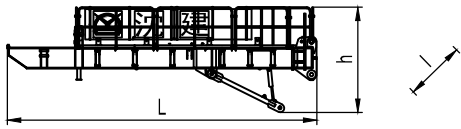
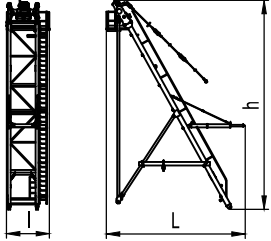
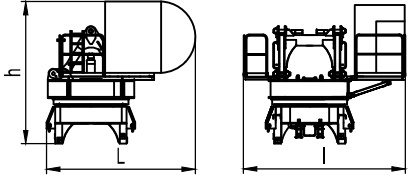
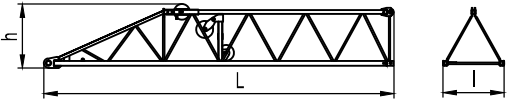
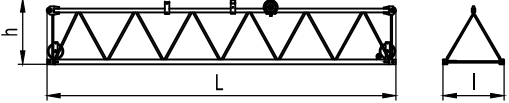
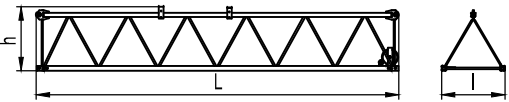
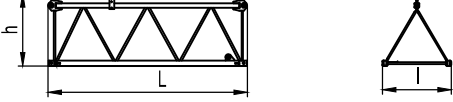
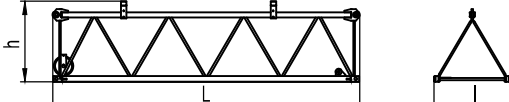
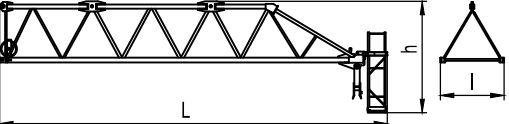
塔机回转部分 Slewing		L(m)	l(m)	h(m)	Kg
平衡臂 Counter-jib		8.7	4	3.3	8315
塔头 Cat-head		7.1	2.48	11.8	6000
回转机构 Slewing mechanism		3.8	4.6	4	10735
起重臂节 Jib section		10.23	1.79	1.87	2300
起重臂节 Jib section		10.2	1.79	1.95	1970
起重臂节 Jib section		10.2	1.79	1.9	1945
起重臂节 Jib section		5.2	1.79	1.89	1035
起重臂节 Jib section		7.2	1.79	1.89	1430
起重臂节 Jib section		10.9	1.82	3.15	2605

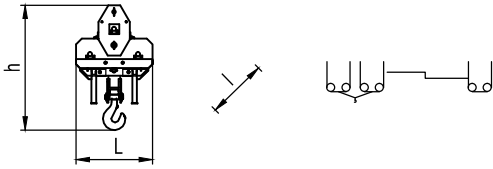
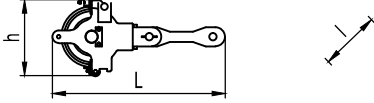
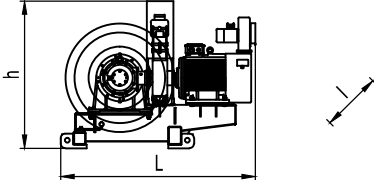
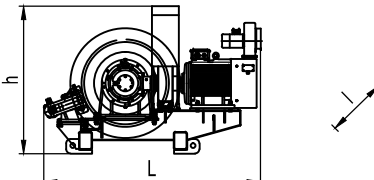
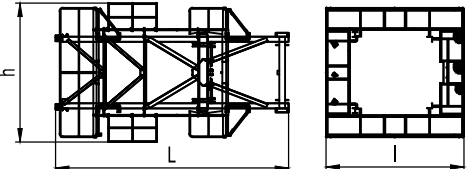
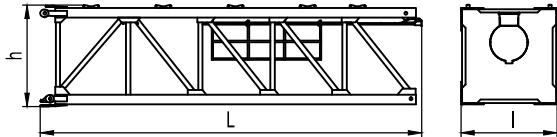
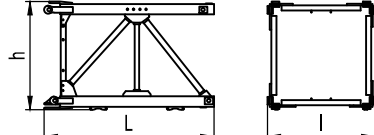
塔机回转部分 Slewing		L(m)	l(m)	h(m)	Kg
吊钩滑轮组 Hook assembly		1.34	0.83	2.2	900
变幅滑轮组 Luffing pulley block		1.4	0.5	0.6	230
起升机构 Hoisting mechanism		2.2	2.35	1.7	3115
变幅机构 Luffing mechanism		2.44	1.96	1.66	3076
顶升装置 Telescoping equipment		L(m)	l(m)	h(m)	Kg
顶升套架 Telescopic cage		7.26	4.3	4.4	5810
塔身部分 Mast		L(m)	l(m)	h(m)	Kg
基础节 Basic mast		7.95	2.1	2.11	5300
标准节 Standard mast		3.31	2.1	2.11	2260

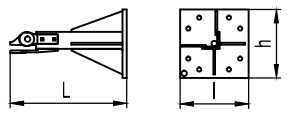
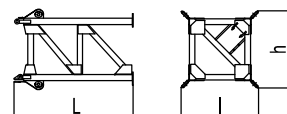
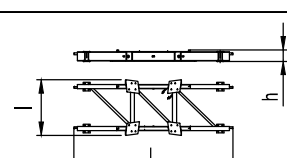
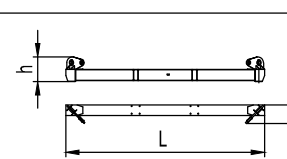
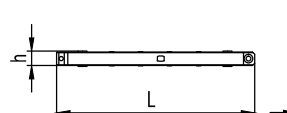
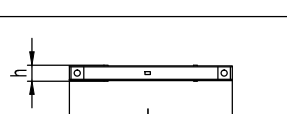
底部 Base		L(m)	l(m)	h(m)	Kg
固定支脚 Fixing angles		1.37	0.8	0.8	470
底架塔节 Chassis mast		3.82	2.5	2.5	4077
底架纵梁 Side member		7.14	2.51	0.52	1840
底架横梁 Traverse		6.38	0.59	0.8	1264
底架撑杆 Brace rod		4.45	0.35	0.34	542
底架水平杆 Horizontal member		2.44	0.24	0.24	156

机构特性 Mechanisms specification														Kw	
起升 Hoisting		75JLF45BY	m/min	0-5.4	0-22.5	0-45	0-67.5	0-90	0-2.7	0-11.25	0-22.5	0-33.75	0-45	610	75
			t	9	9	9	4.5	2.25	18	18	18	9	4.5	>610*	
变幅 Luffing		63JLF50BY	min	0-3										63	
回转 Slewing		9SVF	r/min	0-0.8										9x2	
		145SVT												145Nm x2	
行走 Travelling		5.2TRVF	m/min	0-15										5.2x4	
电源		Power Supply		380V 50Hz / 440V 60Hz											
KVA 供电容量		Necessary Electric Power		200KVA											

* 同我们协商, Consult us

* 标准配置, Standard configuration

平衡臂配重
Counter-jib ballast

		(t)
60m	8.5m	34
55m	8.5m	32
50m	8.5m	30
45m	8.5m	29
40m	8.5m	27
35m	8.5m	25
30m	8.5m	22

可变换的其它安装方式
Mounting possibilities

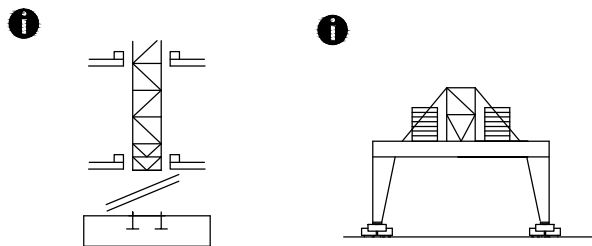

同我们协商
Consult us

F 反力 ● 工作状态 In service 自重 不带荷载及配重, 最大臂长及标准高度时的自重.
Reactions ■ 非工作状态 Out of service Self-load Without load and counter-weight with longest jib and standard height