

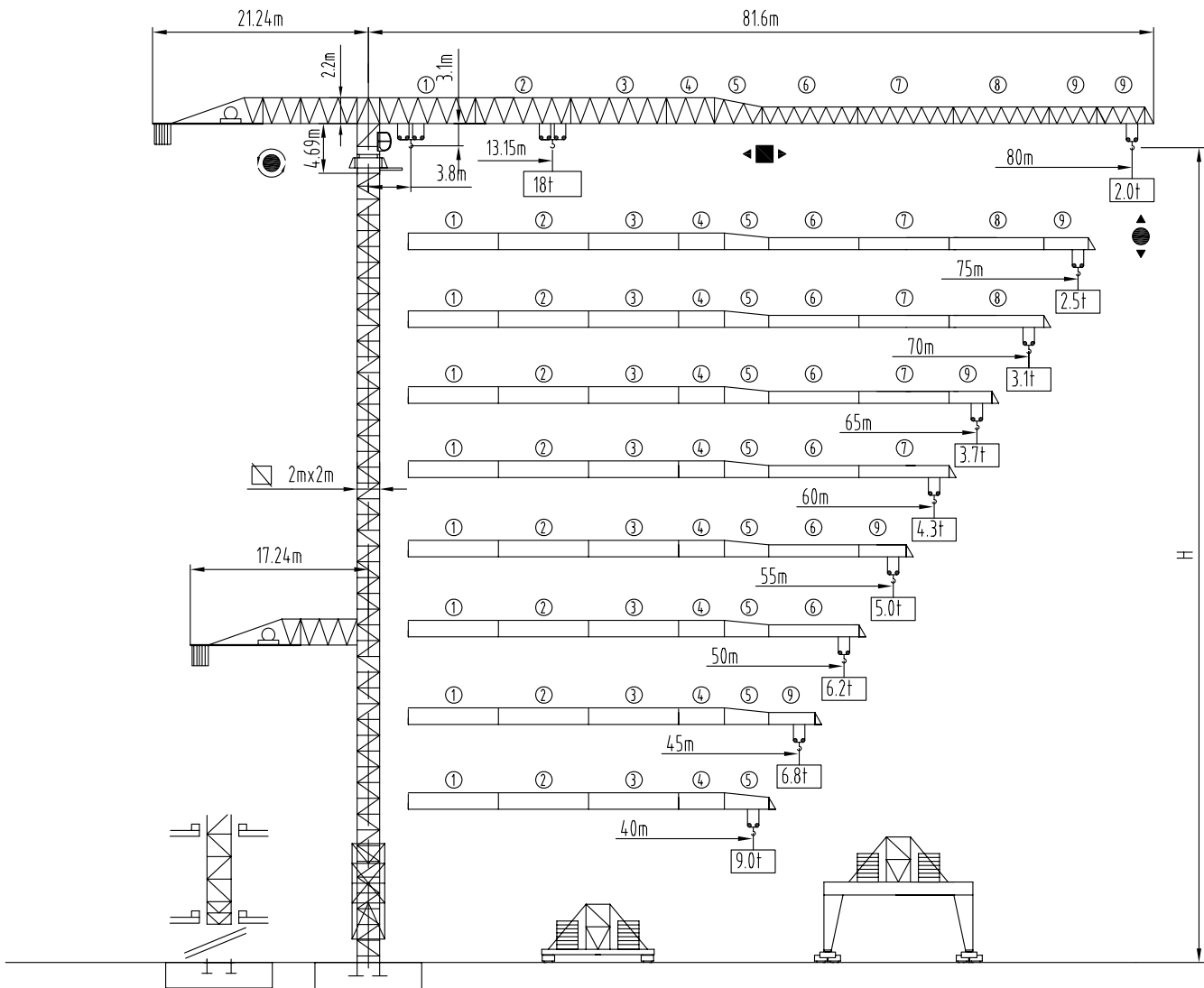

沈阳三洋建筑机械有限公司
SHENYANG SANYO BUILDING MACHINERY CO., LTD

Max Load: 18Ton
Jib: 80M
Tip Load: 2.0Ton
Free Standing: 49.8M

TOWER CRANE QTP 310t · m
(R80/20B)





塔身截面 L68B1 Mast □ 2mx2m

40-80m

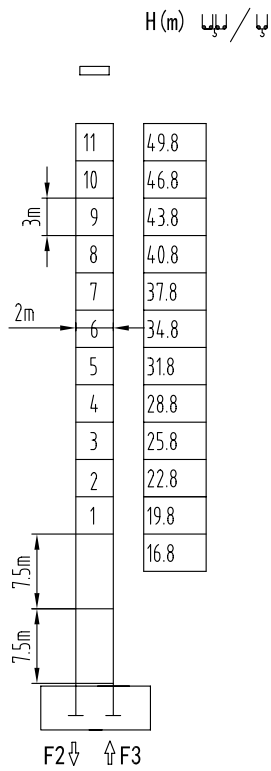

F2	• 160t	▪ 162t
F3	• 84t	▪ 105t
	84t	

固定式附着高度 Anchoring height of stationary crane

★ 紧固附着框 Anchorages tightened

△ 放松附着框 Anchorages released

如需达到更高的高度，请与我们联系。For greater heights, consult us.

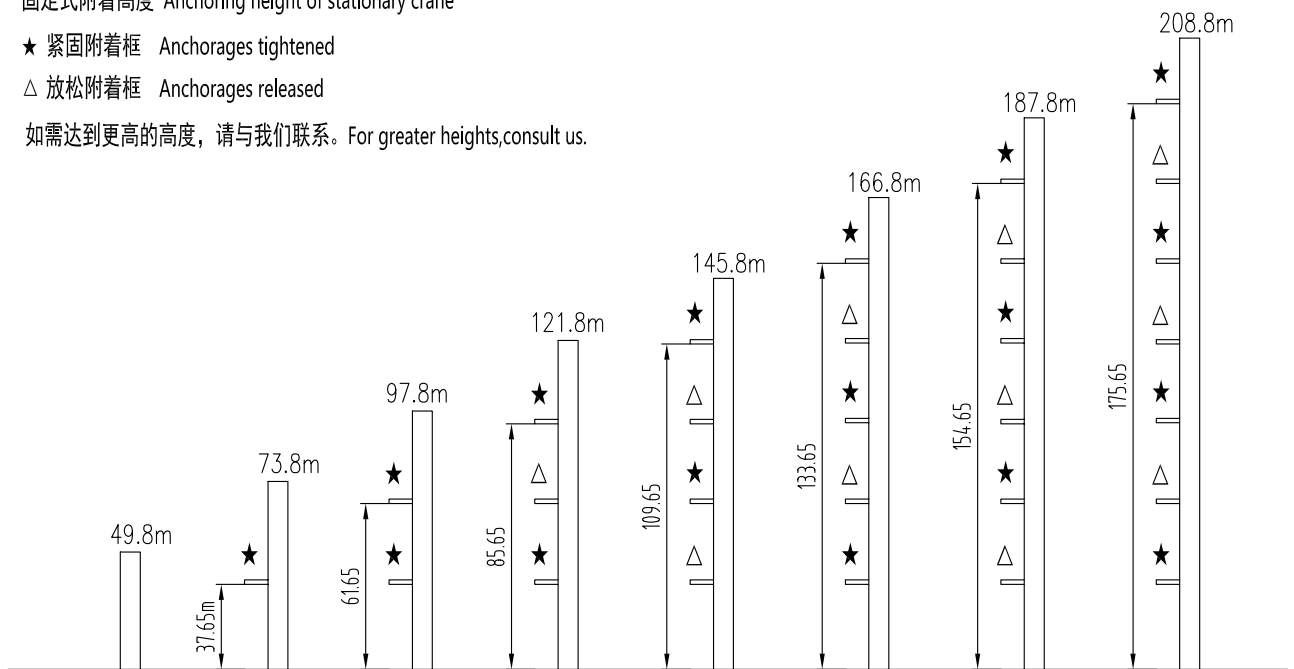

载荷特性 Load diagrams

80m	3.8-	13.15	15	20	23.45	30	35	40	45	50	55	60	65	70	75	80	m
	لپلپ	18	15.4	10.9	9	6.64	5.43	4.45	3.84	3.29	2.84	2.45	2.15	1.88	1.65	1.45	t
	3.8-																m
	لپ	9															t
75m	3.8-	14.45	15	20	24.91	30	35	40	45	50	55	60	65	70	75	m	
	لپلپ	18	16.5	11.74	9	7.14	5.86	4.91	4.17	3.58	3.11	2.71	2.38	2.09	1.95	t	
	3.8-																m
	لپ	9															t
70m	3.8-	15.53	20	25	27.87	30	35	40	45	50	55	60	65	70	m		
	لپلپ	18	13.39	10.27	9	8.22	6.78	5.71	4.88	4.22	3.69	3.24	2.87	2.55	t		
	3.8-																m
	لپ	9															t
65m	3.8-	16.44	20	25	29.57	35	40	45	50	55	60	65	m				
	لپلپ	18	14.33	11.01	9	7.30	6.17	5.29	4.59	4.02	3.54	3.15	t				
	3.8-																m
	لپ	9															t
60m	3.8-	17.05	20	25	30	31.75	35	40	45	50	55	60	m				
	لپلپ	18	14.95	11.51	9.25	9	7.65	6.47	5.56	4.83	4.24	3.75	t				
	3.8-																m
	لپ	9															t
55m	3.8-	17.62	20	25	30	31.75	35	40	45	50	55	m					
	لپلپ	18	15.54	11.98	9.63	9	7.98	6.76	5.81	5.06	4.45	t					
	3.8-																m
	لپ	9															t
50m	3.8-	18.09	20	25	30	32.62	35	40	45	50	m						
	لپلپ	18	16.03	12.36	9.95	9	8.25	6.99	6.25	5.65	t						
	3.8-																m
	لپ	9															t
45m	3.8-	18.59	20	25	30	33.56	40	45	m								
	لپلپ	18	16.55	12.77	10.3	9	7.25	6.25	t								
	3.8-																m
	لپ	9															t
40m	3.8-	20.98	25	30	35	37.98	m										
	لپلپ	18	14.72	11.91	9.92	9	t										
	3.8-																m
	لپ	9															t

$لپلپ = لپ - 0.55t$

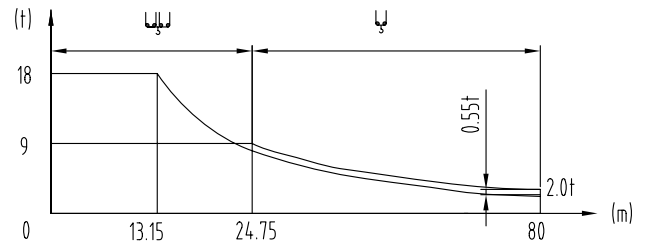

لپ / لپلپ 标准小车可使用 2/4倍率绳 standard trolley 2/4 fall.

使用四倍率时，应从二倍率的载荷中减去0.55吨

When using لپلپ subtract 0.55t from the loads لپ

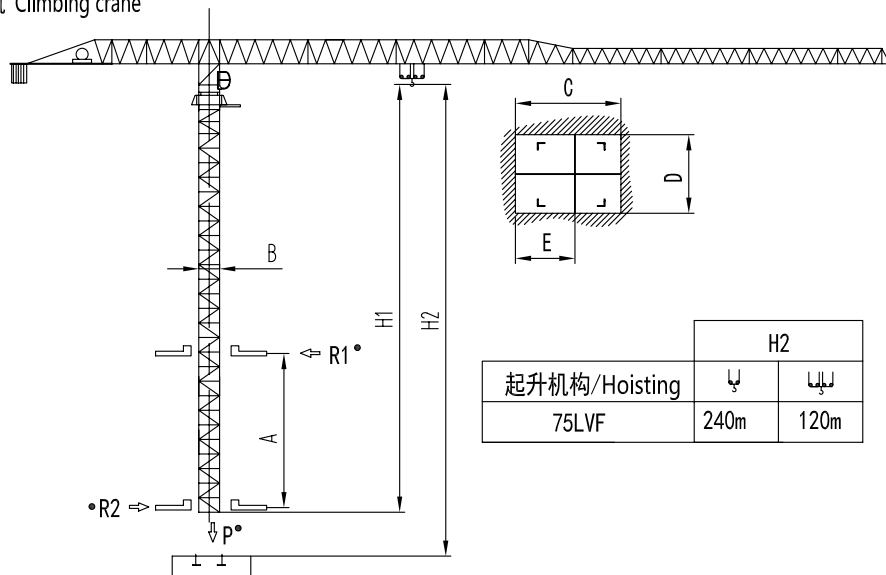

内爬塔机 Climbing crane



B	2m
C	3m
D	2.2m
E	1.5m

其他参数同我们联系

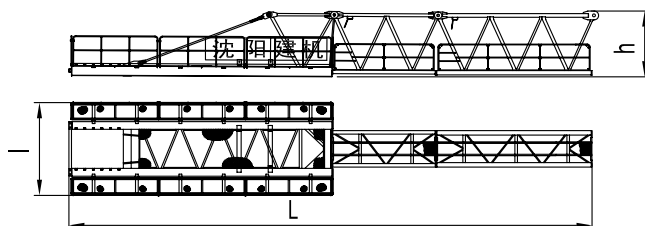
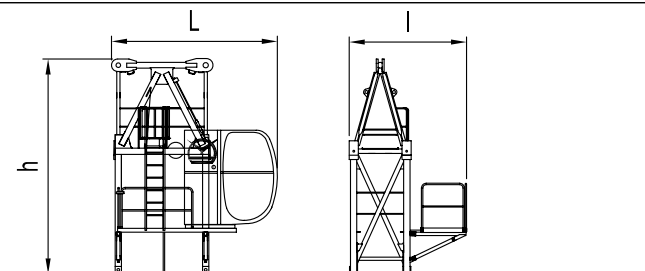
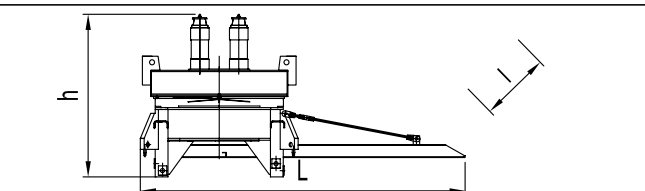
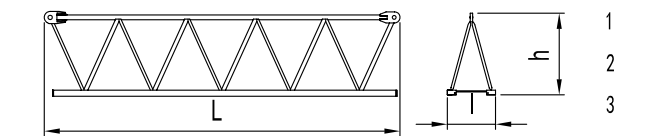
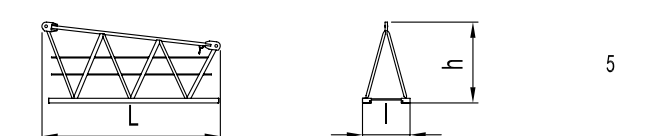
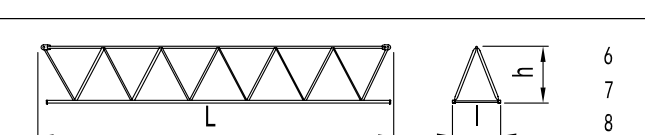
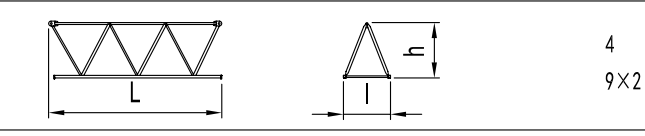
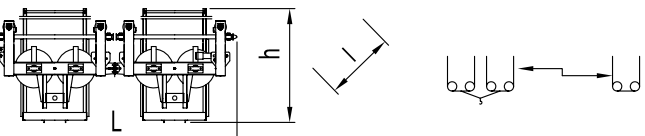
外形尺寸重量表 Dimensions weights

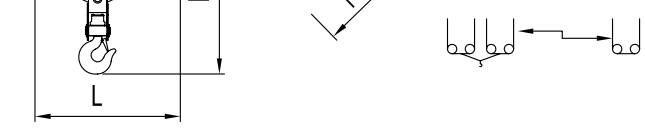
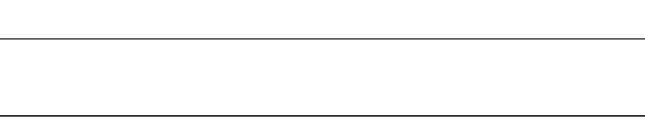
塔机回转部分 Slewing		L(m)	l(m)	h(m)	Kg
平衡臂 Counter-jib		20.4	3.6	2.54	9480
塔头 Cat-head		4.1	3.05	5.3	3940
回转机构 Slewing mechanism		5.1	2.5	2.65	7500
起重臂节 Jib section		10.34	1.4	2.45	4200
		10.31	1.4	2.43	3495
		10.28	1.4	2.4	2650
起重臂节 Jib section		5.24	1.4	2.38	1290
起重臂节 Jib section		10.23	1.4	1.77	1748
		10.17	1.4	1.74	1446
		10.15	1.4	1.72	960
起重臂节 Jib section		5.24	1.4	2.38	1310
		5.15	1.4	1.72	582x2
变幅小车 Trolley		3.2	1.8	1.7	685
吊钩滑轮组 Hook assembly		1.7	0.3	1.9	550

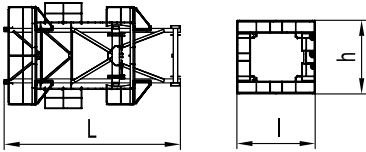
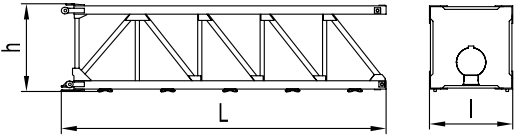
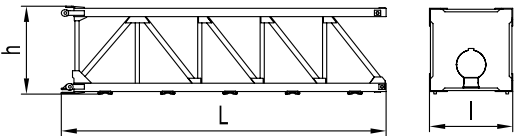
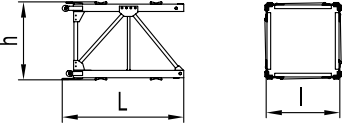
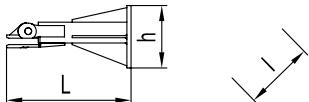
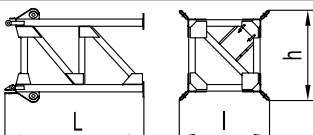
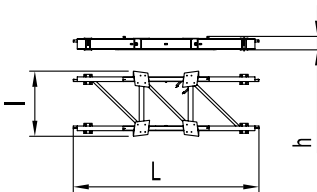
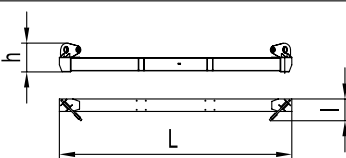
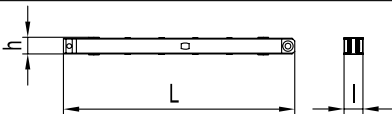
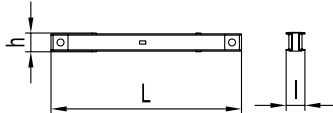
顶升装置 Telescoping equipment		L(m)	l(m)	h(m)	Kg
顶升套架 Telescopic cage		7.26	4.3	4.05	4825
塔身部分 Mast		L(m)	l(m)	h(m)	Kg
基础节7.5m 7.5m Basic mast		7.805	2.096	2.108	4641
基础节7.5m 7.5m Basic mast		7.805	2.096	2.108	4340
标准节 Standard mast		3.3	2.0	2.1	1820
底部 Base		L(m)	l(m)	h(m)	Kg
固定支脚 Fixing angles		1.365	0.8	0.8	490
底架塔节 Chassis mast		3.82	2.6	2.6	3700
底架纵梁 Side member		7.14	2.51	0.62	2500
底架横梁 Traverse		6.42	0.62	0.91	1500x2
底架撑杆 Brace rod		4.54	0.37	0.4	941x4
底架水平杆 Horizontal member		2.44	0.24	0.24	156x4

机构特性 Mechanisms specification														Kw	
起升 Hoisting		75LVF	m/min	0-5.4	0-22	0-45	0-67.4	0-90	0-2.7	0-11	0-22.5	0-33.7	0-45	500	75
			t	9	9	9	4.5	2.25	18	18	18	9	4.5		
变幅 Trolleying		7.5TVF	m/min	0-65									7.5		
回转 Slewing		9SVF	r/min	0-0.8									9x3		
		14.5SVT											14.5Nm x 3		
行走 Travelling		5.2TRVF	m/min	0-15									5.2x4		
电源		Power Supply		380V 50Hz / 440V 60Hz											
KVA 供电容量		Necessary Electric Power		150KVA											

平衡臂配重
Counter-jib ballast

		(t)
80m	21.24m	26.3
75m	21.24m	24.67
70m	21.24m	23.0
65m	21.24m	22.07
60m	21.24m	20.44
55m	21.24m	18.21
50m	17.24m	24.67
45m	17.24m	21.37
40m	17.24m	21.14

可变换的其它安装方式
Mounting possibilities

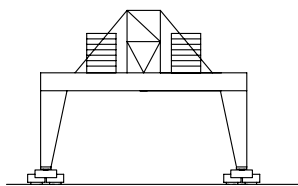
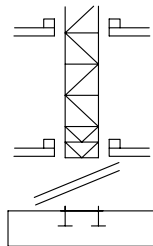

同我们协商
Consult us

F 反力
Reactions

- 工作状态 In service
- 非工作状态 Out of service

自重
Self-load

不带载荷及配重, 最大臂长及标准高度时的自重.
Without load and counter-weight with longest jib and standard height