

X Pol Panel TD Antenna 3300-3800MHz 80° 15dBi 2°-12° Replaceable RET

XXXXX Pol 698-960/4×1695-2690MHz 65°/65° 14/14dBi 2°-12°/2°-12° Replaceable RET

Electrical Specifications (3300-3800MHz)

General parameters	Frequency range (MHz):		3300-3800(P1)	
	Polarization:		±45°	
	Electrical downtilt (°):		2-12 , continuously adjustable	
	Connector Type:		1xMQ5,1xMQ4	
Calibration and electrical parameters	Coupling factor between calibration port and each antenna port (dB) :		-26±2	
	Max Amp/phase Deviation:		<1.2/ 12°	
	VSWR:		<1.5	
	Max. Power Per Port (W):		40	
	Co-polarization isolation between ports (dB):		>20	
Radiation parameters	Single Column	Horizontal 3dB Beamwidth (°):		80±10
		Vertical 3dB Beamwidth (°):		7
		Front to Back Ratio (dB):		23
		Gain (dBi):		14.5±0.5
		Cross polar ratio (dB):		>15 (0°)/>8 (±60°)
	Broadcast Beam	Horizontal 3dB Beamwidth (°):		65±10
		Gain (dBi):		16.0±0.5
		Front to Back Ratio (dB):		25
		Vertical 3dB Beamwidth (°):		7
		Cross polar ratio (dB):		>15 (0°)/>8 (±60°)
	Service Beam @ 0deg	Gain (dBi):		19.5±0.5
		Horizontal 3dB Beamwidth (°):		19
		Horizontal Sidelobe Level (dB):		<-12
		Cross polar ratio (0°) (dB):		15
		Front to Back Ratio (dB):		25
Service Beam@ 60deg	Gain (dBi):		16.0±0.5	
	Horizontal 3dB Beamwidth (°):		20	
	Horizontal Sidelobe Level (dB):		<-3	

Electrical Specifications (698-960/1695-2690 MHz)

Frequency Range (MHz):	698-960(R1)			1695-2690(Y1,Y2,Y3,Y4)		
	698-806	806-880	880-960	1695-2170	2300-2490	2490-2690
Gain (dBi):	13.0±0.5	13.5±0.5	14.0±0.5	13.2±0.5	13.8±0.5	14.0±0.5
Return Loss (dB):	>14 (VSWR<1.5)					
Polarization:	±45°					
Horizontal 3dB beamwidth (°):	65	62	58	68	65	60
Vertical 3dB beamwidth (°):	17.5	16.0	15.0	13.5	11.5	11.0
Electrical Downtilt (°):	2-12 Continuously Adjustable			2-12 Independently Continuously Adjustable		
Front to Back Ratio @180±30°(dB):	22	23	24	25	25	25
1st Upper Sidelobe Suppression (dB):	15	15	15	15	15	15
Cross Polar Ratio 0° (dB):	15	15	15	15	15	15
Intraband Isolation (dB):	>24					
Interband Isolation (dB):	>24					

Max. Power Per Port (W):	250	200
Intermodulation IM3 (dBc):	<-150 (2x43dBm)	
Impedance (ohm):	50	
Lightning Protection:	DC Grounded	
Connector Type:	10x4.3-10 Female	

BASTA Electrical Specifications

Frequency Range(MHz):	698-960(R1)			4x1695-2690(Y1,Y2,Y3,Y4)			3300-3800(P1)
	698-806	806-880	880-960	1695-2170	2300-2490	2490-2690	
Average Gain by all Beam Tilts (dBi):	12.8	13.0	13.6	13.0	13.3	13.9	14.1
Gain by all Beam Tilts Tolerance(dB):	±0.5	±0.5	±0.5	±1.4	±1.1	±0.7	±0.9
Average Gain by Beam Tilt (dBi):	2° 13.0	2° 13.1	2° 13.9	2° 13.1	2° 13.4	2° 14.2	2° 14.6
	7° 12.8	7° 12.9	7° 13.7	7° 12.9	7° 13.3	7° 14.0	7° 14.0
	12° 12.6	12° 12.8	12° 13.3	12° 12.8	12° 12.9	12° 13.5	12° 13.2
Horizontal Beamwidth Tolerance(°):	±4.2	±3.5	±4.6	±6.5	±4.1	±6.0	±12.1
Vertical Beamwidth Tolerance(°):	±1.9	±1.9	±1.6	±2.3	±1.7	±1.4	±1.5
1st Upper Sidelobe Suppression (dB) :	15.9	15.6	15.8	15.5	15.9	15.1	15.8
Front to back Total Power at 180° ± 30°(dB):	22.2	23.5	24.2	25.2	25.8	25.3	23.5
CPR at Boresight(dB):	15.9	17.6	16.5	15.7	16.9	16.9	16.8

Mechanical Data

Antenna Dimensions (mm):	1390x396x190
Packing Dimensions (mm):	1680x485x285
Antenna Net Weight/Bracket (kg): (kg):	25/5.7
Antenna Gross Weight (kg):	35
Radome Material:	Fiberglass
Pipe OD (mm):	70-114
Mounting Kits (Included):	BA.K.04.00053, Adjustable Downtilt 0°-14°

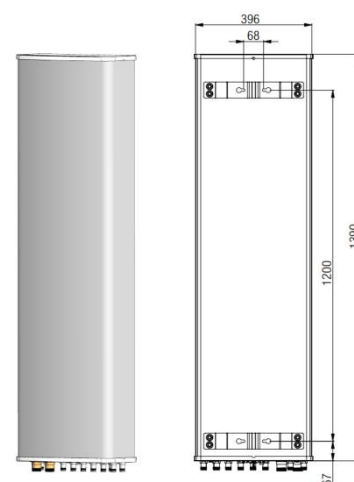
**Environmental Ratings**

Humidity:	95%RH@+30°C
Temperature (°C):	-40~+70
Wind Load @150 km/h (N):	Frontal/ Lateral/ Rearside:732/218/966
Max. Wind velocity(km/h):	200

Internal RET Specifications

RET type:	RET Replaceable RET
RET protocol:	AISG 2.0 /3 GPP
Input voltage range(V):	10-30 DC
Power consumption (W):	< 5 (motor activated , single RET) < 1 (stand by, single RET), < 1.5 (stand by, 12V)
Adjustment time (full range) (s):	< 120 (typically, depending on antenna type)
RET connector:	one pair of AISG 5 pin male & female
Pin assignment according AISG:	8 pin circular connector conforming to IEC 60130-9 - Ed. 3.0
Lightning protection (kA):	5 (8/20 μs Differential mode), 8 (8/20 μs Common mode)

Typical Patterns

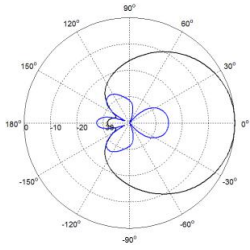

Single Column

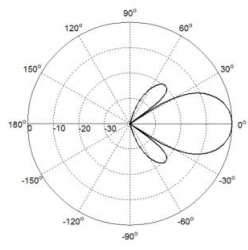

Service Beam @0deg

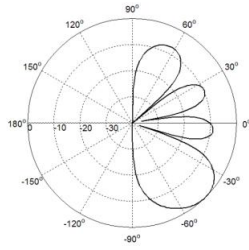

Service Beam @60deg

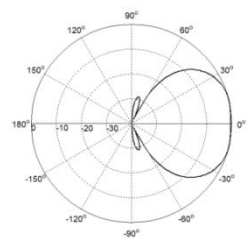

Broadcast Beam

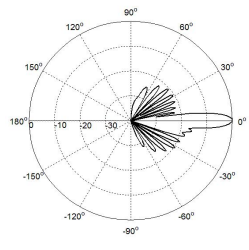

Elevation

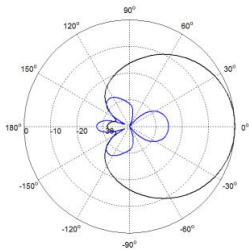

Azimuth(698-960MHz)

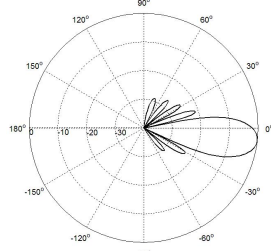

Elevation(698-960MHz)

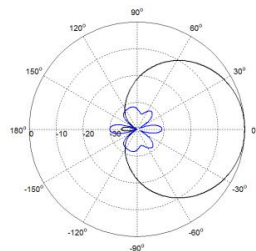

Azimuth(1695-2690MHz)

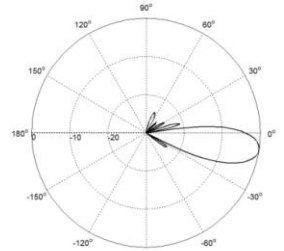

Elevation(1695-2690MHz)

Correlation Table

Frequency Range	Array	Connector	RET
698-960 MHz	R1	1-2	BRxxx.....R1
1695-2690 MHz	Y1	3-4	BRxxx.....Y1
1695-2690 MHz	Y2	5-6	BRxxx.....Y2
1695-2690 MHz	Y3	7-8	BRxxx.....Y3
1695-2690 MHz	Y4	9-10	BRxxx.....Y4
3300-3800 MHz	P1	1xMQ5,1xMQ4	BRxxx.....P1

MQ4/MQ5 Port Mapping

Connector	Pin	Frequency	Polarization/Port
MQ5	1	3300-3800 MHz	+45
	2	3300-3800 MHz	+45
	3	3300-3800 MHz	+45
	4	3300-3800 MHz	+45
	5	3300-3800 MHz	Calibration port
MQ4	1	3300-3800 MHz	-45
	2	3300-3800 MHz	-45
	3	3300-3800 MHz	-45
	4	3300-3800 MHz	-45

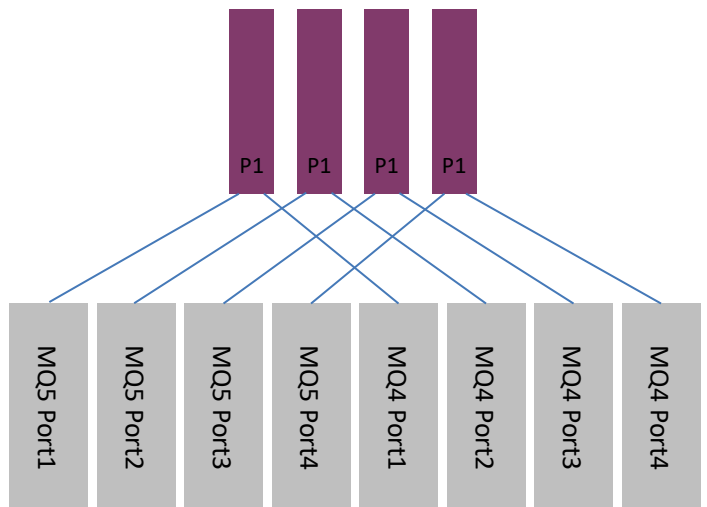
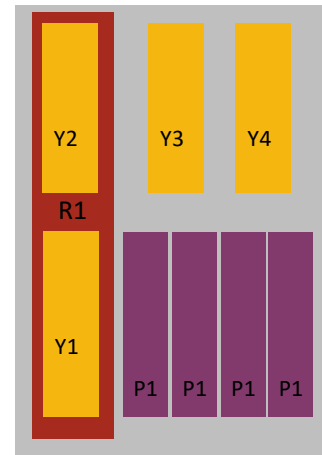

Bottom View

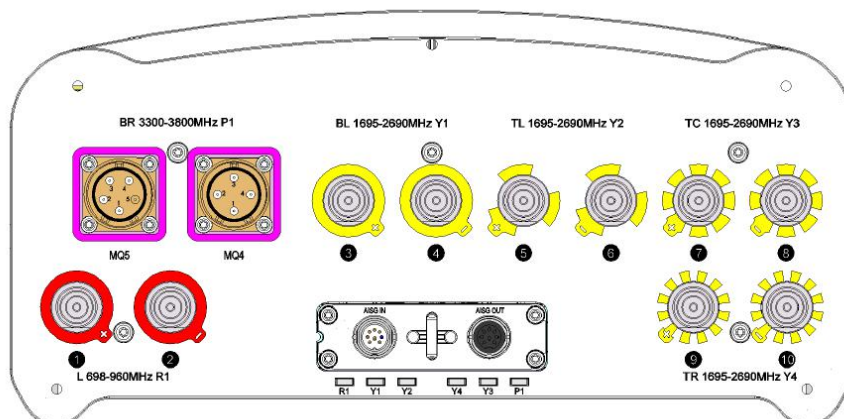

Broadcast Beam Weight Value for Reference

		P1/P5	P2/P6	P3/P7	P4/P8
2C(3300-3800MHz)	Amp[li]	1	1	0.65	0.25
	Phase	0	-20	180	-20
3C(3300-3800MHz)	Amp[li]	1	1	0.65	0.25
	Phase	0	-16	180	-16
4C(3300-3800MHz)	Amp[li]	1	1	0.65	0.25
	Phase	0	-12	180	-12
5C(3300-3800MHz)	Amp[li]	1	1	0.65	0.25
	Phase	0	-8	180	-8
6C(3300-3800MHz)	Amp[li]	1	1	0.65	0.25
	Phase	0	-4	180	-4
7C(3300-3800MHz)	Amp[li]	1	1	0.65	0.25
	Phase	0	0	180	0
8C(3300-3800MHz)	Amp[li]	1	1	0.65	0.25
	Phase	0	4	180	4
9C(3300-3800MHz)	Amp[li]	1	1	0.65	0.25
	Phase	0	8	180	8
10C(3300-3800MHz)	Amp[li]	1	1	0.65	0.25
	Phase	0	12	180	12
11C(3300-3800MHz)	Amp[li]	1	1	0.65	0.25
	Phase	0	16	180	16
12C(3300-3800MHz)	Amp[li]	1	1	0.65	0.25
	Phase	0	20	180	20