



**Report Number: MIC-ASI1641002**

**Audit Date :** 02 Nov.,2016

This report is issued by Focus Technology Co., Ltd. (Made-in-China.com) and the supervising inspectorate (TÜV SÜD Certification and Testing (China) Co., Ltd.) to confirm that:

**Company Name :** Zhangjiagang Fenghua Machinery Co., Ltd.  
张家港丰华机械有限公司

**Showroom :** <http://fenghuamachine.en.made-in-china.com>

**Address :** Xigang Village, Jinfeng Town, Zhangjiagang City, Suzhou City, Jiangsu Province, China

**Product :** Plastic Pipe Machine, Waste Plastic Recycling Machine, Plastic Profile Machine, Waste Plastic Shredder Machine, Waste Plastic Crusher Machine.

has been on site audited for the Following Scope of Activity

1. General Information
2. Foreign Trade Capacity
3. Management System and Product Certification
4. Production Capacity & Quality Control
5. Photos



**General Comments:**

Zhangjiagang Fenghua Machinery Co., Ltd was established in 1995, located in Xigang Village, Jinfeng Town, Zhangjiagang City, Suzhou City, Jiangsu Province, China. Its main products are Plastic Pipe Machine, Waste Plastic Recycling Machine, Plastic Profile Machine, Waste Plastic Shredder Machine, Waste Plastic Crusher Machine. Main products have passed CE certificate, Zhangjiagang Fenghua Machinery Co., Ltd has its own brand “丰华”. And they have successful foreign trading experience in South America, Europe, Africa and Southeast Asia/ Mideast.

Sign for and on behalf of  
TÜV SÜD Certification and Testing (China) Co., Ltd.

This document is issued by the Company called TÜV SÜD Certification and Testing (China) Co., Ltd.. Attention is drawn to the limitation of liability, indemnification and jurisdiction issues defined therein. Any holder of this document is advised that information contained hereon is solely limited to a visual examination of the safety and readily accessible portions of consignment and reflects the Company's findings at the time of its intervention only and within the limits of Client's instructions, if any. The company's sole responsibility is to its Client and this document does not exonerate parties to a transaction from exercising all their rights and obligations under the applicable laws. Any unauthorized alteration, forgery or falsification of the content or appearance of this document is unlawful and offenders may be prosecuted to the fullest extent of the law..

Attention: To check the authenticity of testing/inspection report & certificate, please email: [info.MIC@tuv-sud.cn](mailto:info.MIC@tuv-sud.cn) or click: [www.tuv-sud.cn/mic-cn](http://www.tuv-sud.cn/mic-cn); [www.tuv-sud.cn/mic-en](http://www.tuv-sud.cn/mic-en)



# SUPPLIER ASSESSMENT REPORT

|                        |   |
|------------------------|---|
| <b>Audited Company</b> | Zhangjiagang Fenghua Machinery Co., Ltd.  |
| <b>Audited Site:</b>   | Xigang Village, Jinfeng Town, Zhangjiagang City, Suzhou City, Jiangsu Province, China |

|                                |  |                      |  |
|--------------------------------|--|----------------------|--|
| <b>Consigner of Assessment</b> | <b>Made-in-China.com</b>   |                      |  |
| <b>Audit Type</b>              | <input checked="" type="checkbox"/> Initial Audit<br><input type="checkbox"/> Re-audit |                      |  |
| <b>Audit Date</b>              | 02 Nov.,2016   | <b>Verify Report</b> | <a href="http://www.tuv-sud.cn/mic-cn">www.tuv-sud.cn/mic-cn</a><br><a href="http://www.tuv-sud.cn/mic-en">www.tuv-sud.cn/mic-en</a> |
| <b>Auditor</b>                 | Roy Zhou   | <b>Reviewed by</b>   | James Qing   |

## CONTENTS

- Part A: General Information**
  - Section 1: Company Overview
  - Section 2: Human Resources
- Part B: Foreign Trade Capacity**
  - Section 1: Export Overall Situation
  - Section 2: Export Business Capacity
  - Section 3: Supplier Management
  - Section 4: After-sales Service Capacity
- Part C: Product Research & Development Capacity**
  - Section 1: Product Research & Development Capacity
- Part D: Management System and Product Certification**
  - Section 1: Management System(s) and Product Certification
- Part E: Production Capacity & Quality Control**
  - Section 1: Production Capacity Section
  - Section 2: Production Process Control
- Part F: Financial Position**
  - Section 1: Financial Data
  - Section 2: Key Performance Indications
  - Section 3: Banking
  - Section 4: Product Insurance
- Part G: Working Environment**
  - Section 1: Working Environment
- Part H: Energy Saving and Emission Reduction**
  - Section 1: Environmental Management
  - Section 2: Water, Gas and Noise Control
- Part I: Industry Information**
  - Section 1: Industry Information
- Part J: Photos**
  - Section 1: Photos of Documents
  - Section 2: Photos of Company

This document is issued by the Company called TÜV SÜD Certification and Testing (China) Co., Ltd.. Attention is drawn to the limitation of liability, indemnification and jurisdiction issues defined therein. Any holder of this document is advised that information contained hereon is solely limited to visual examination of the safety and readily accessible portions of consignment and reflects the Company's findings at the time of its intervention only and within the limits of Client's instructions, if any. The company's sole responsibility is to its Client and this document does not exonerate parties to a transaction from exercising all their rights and obligations under the transaction document. Any unauthorized alteration, forgery or falsification of the content or appearance of this document is unlawful and offenders may be prosecuted to the fullest extent of the law..

Attention: To check the authenticity of testing/inspection report & certificate, please email: [info.MIC@tuv-sud.cn](mailto:info.MIC@tuv-sud.cn) or click: [www.tuv-sud.cn/mic-cn](http://www.tuv-sud.cn/mic-cn); [www.tuv-sud.cn/mic-en](http://www.tuv-sud.cn/mic-en)



## Part A: General Information

### Section 1: Company Overview

| 1.1 Legal Validity   |  |                     |                    |
|--|--|---------------------|--------------------|
| Does the company have a valid business license?  | <input checked="" type="checkbox"/> Yes <input type="checkbox"/> No <input type="checkbox"/> Others  | Registration Number | 91320582704066040Q |
| Year of established  | 17 Apr., 1995  | Valid Date          | Long Valid         |
| Registered address   | Xigang Village, Jinfeng Town, Zhangjiagang City, Suzhou City, Jiangsu Province, China  |                     |                    |
| Actual address   | Xigang Village, Jinfeng Town, Zhangjiagang City, Suzhou City, Jiangsu Province, China  |                     |                    |
| Does the company in abnormal operation status list of industrial and commercial bureau?  | No   |                     |                    |
| Registered capital   | 500000 RMB   |                     |                    |
| Name of legal representative   | LiuxianShen  |                     |                    |
| Business scope   | Plastic industrial special equipment for beverage machinery equipment special rubber products, glass fiber reinforced plastic products construction machinery and equipment Wash equipment auto parts machinery parts manufacturing processing and sales; Self-management and agent all kinds of goods and technology import and export business. (Except for State enterprises or prohibit the import and export goods and technology). (Project is subject to ratification in accordance with the law, the relevant department approval to operate). |                     |                    |
| 1.2 Basic Information  |  |                     |                    |
| Contact person   | Le Shen  |                     |                    |
| Phone number   | 86-512-58200688  | Fax number          | 86-512-58280080    |
| URL/Web address  | <a href="http://www.fenghuaix.com">http://www.fenghuaix.com</a>  |                     |                    |
| Company type   | <input type="checkbox"/> Manufacturer <input type="checkbox"/> Trading Company<br><input checked="" type="checkbox"/> Combined <input type="checkbox"/> Group Corporation  |                     |                    |
| Type of ownership  | <input checked="" type="checkbox"/> Limited Company <input type="checkbox"/> Public Company <input type="checkbox"/> Foreign joint venture<br><input type="checkbox"/> State-Owned <input type="checkbox"/> Private Owner <input type="checkbox"/> Wholly foreign-owned enterprises  |                     |                    |
| Subsidiary company   | No   |                     |                    |
| Products manufactured / sold scope   | Plastic Pipe Machine, Waste Plastic Recycling Machine, Plastic Profile Machine, Waste Plastic Shredder Machine, Waste Plastic Crusher Machine.   |                     |                    |
| 1.3 Company Building Information   |  |                     |                    |
| According to:  |  |                     |                    |
| <input checked="" type="checkbox"/> Land certificate <input type="checkbox"/> Real estate certificate<br><input type="checkbox"/> Lease agreement <input type="checkbox"/> Observation Estimated on site |  |                     |                    |
| The company area 6000 square meters<br>The land occupies 4861.3 square meters.<br>The offices occupy 1000 square meters.<br>The workshops occupy 5000 square meters.                                     |  |                     |                    |

This document is issued by the Company called TÜV SÜD Certification and Testing (China) Co., Ltd.. Attention is drawn to the limitation of liability, indemnification and jurisdiction issues defined therein. Any holder of this document is advised that information contained hereon is solely limited to the examination of the safety and readily accessible portions of consignment and reflects the Company's findings at the time of its intervention only and within the limits of Client's instructions, if any. The company's sole responsibility is to its Client and this document does not exonerate parties to a transaction from exercising all their rights and obligations under the transaction document. Any unauthorized alteration, forgery or falsification of the content or appearance of this document is unlawful and offenders may be liable to criminal prosecution and civil claims to the fullest extent of the law..

Attention: To check the authenticity of testing/inspection report & certificate, please email: [info.MIC@tuv-sud.cn](mailto:info.MIC@tuv-sud.cn) or click: [www.tuv-sud.cn/mic-cn](http://www.tuv-sud.cn/mic-cn); [www.tuv-sud.cn/mic-en](http://www.tuv-sud.cn/mic-en)



## Section 2: Human Resources

### 2.1 Company Chart

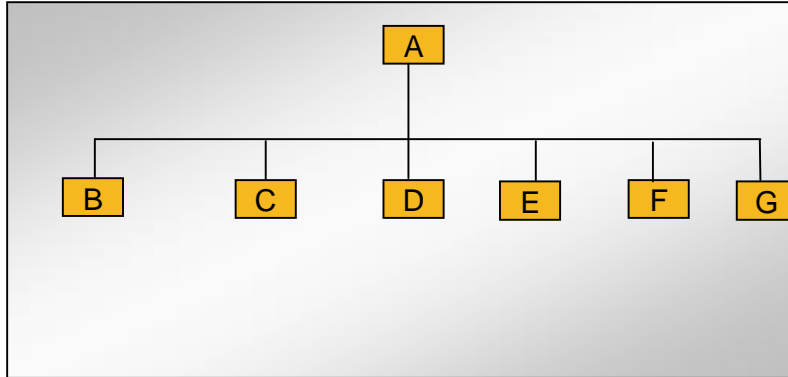

### 2.2 Explanation of Code and Employee Details

| Code                    | Department            | Number of employees |
|-------------------------|-----------------------|---------------------|
| A                       | GM                    | 1                   |
| B                       | Sales Department      | 4                   |
| C                       | Technical Department  | 2                   |
| D                       | Production Department | 7                   |
| E                       | Purchase Department   | 2                   |
| F                       | Finance Department    | 1                   |
| G                       | Quality Department    | 1                   |
| <b>Number in total:</b> |                       | 18                  |

### 2.3 Key Staff

| Title         | Full name | Education           | Working experience for this trade / total experience |
|---------------|-----------|---------------------|--|
| Sales Manager | Hui Tang  | University graduate | 6/6  |

Remark: Above information of key staff was based on interview with company representative.





## Part B: Foreign Trade Capacity

### Section 1: Export Overall Situation

| 1.1 Export Overall Situation  |   |
|---|---|
| Does the company have a valid Import and Export license?              | <input checked="" type="checkbox"/> Yes <input type="checkbox"/> No   |
| The import and export enterprise code.                                | 91320582704066040Q  |
| The number of foreign trading staff with relevant trading experience. | <input checked="" type="checkbox"/> within 1 year 1 staff <input checked="" type="checkbox"/> 1-5 years 2 staff<br><input checked="" type="checkbox"/> 6-10 years 1 staff <input type="checkbox"/> over 10 years staff<br>Total 4 staff     |
| The language freely used by foreign trade staff                       | <input checked="" type="checkbox"/> English <input type="checkbox"/> others:  |
| Annual revenue of previous year                                       | Confidential  |
| Annual export revenue of previous year                                | Confidential  |
| Estimated export revenue for this year.                               | Confidential  |
| Overseas agent / branch   | <input type="checkbox"/> Yes <input checked="" type="checkbox"/> No   |
| Nearest port  | Shanghai Port   |
| Acceptable quotation terms  | <input checked="" type="checkbox"/> FOB <input checked="" type="checkbox"/> CIF <input checked="" type="checkbox"/> CFR Other:EXW   |
| Acceptable payment terms  | <input checked="" type="checkbox"/> LC <input checked="" type="checkbox"/> T/T <input type="checkbox"/> D/P <input type="checkbox"/> PayPal<br><input type="checkbox"/> Western Union <input type="checkbox"/> Small-amount payment         |
| Average lead time (Peak Season)                                       | <input type="checkbox"/> within 15 workday <input checked="" type="checkbox"/> one month <input type="checkbox"/> 2-3 months<br><input type="checkbox"/> 4-6 months <input type="checkbox"/> 6-12 months <input type="checkbox"/> more time |
| Average lead time (Off Season)  | <input type="checkbox"/> within 15 workday <input checked="" type="checkbox"/> one month <input type="checkbox"/> 2-3 months<br><input type="checkbox"/> 4-6 months <input type="checkbox"/> 6-12 months <input type="checkbox"/> more time |

### Section 2: Export Business Capacity

| 2.1 Market Distribution (please list top four areas)        |  |              |
|---|--|--------------|
| Market  | Main Product   | Main client  |
| <input type="checkbox"/> North America                      |  |              |
| <input checked="" type="checkbox"/> South America           | Plastic Pipe Machine, Waste Plastic Recycling Machine, Plastic Profile Machine, Waste Plastic Shredder Machine, Waste Plastic Crusher Machine. | Confidential |
| <input checked="" type="checkbox"/> Europe                  | Plastic Pipe Machine, Waste Plastic Recycling Machine, Plastic Profile Machine, Waste Plastic Shredder Machine, Waste Plastic Crusher Machine. | Confidential |
| <input checked="" type="checkbox"/> Southeast Asia/ Mideast | Plastic Pipe Machine, Waste Plastic Recycling Machine, Plastic Profile Machine, Waste Plastic Shredder Machine, Waste Plastic Crusher Machine. | Confidential |
| <input checked="" type="checkbox"/> Africa                  | Plastic Pipe Machine, Waste Plastic Recycling Machine, Plastic Profile Machine, Waste Plastic Shredder Machine, Waste Plastic Crusher Machine. | Confidential |
| <input type="checkbox"/> East Asia (Japan/ South Korea)     |  |              |
| <input type="checkbox"/> Australia                          |  |              |

This document is issued by the Company called TÜV SÜD Certification and Testing (China) Co., Ltd.. Attention is drawn to the limitation of liability, indemnification and jurisdiction issues defined therein. Any holder of this document is advised that information contained hereon is solely limited to the examination of the safety and readily accessible portions of consignment and reflects the Company's findings at the time of its intervention only and within the limits of Client's instructions, if any. The company's sole responsibility is to its Client and this document does not exonerate parties to a transaction from exercising all their rights and obligations under the transaction document. Any unauthorized alteration, forgery or falsification of the content or appearance of this document is unlawful and offenders may be liable to criminal sanctions and/or civil damages to the fullest extent of the law..

Attention: To check the authenticity of testing/inspection report & certificate, please email: [info.MIC@tuv-sud.cn](mailto:info.MIC@tuv-sud.cn) or click: [www.tuv-sud.cn/mic-cn](http://www.tuv-sud.cn/mic-cn); [www.tuv-sud.cn/mic-en](http://www.tuv-sud.cn/mic-en)



|                                   |  |  |
|-----------------------------------|--|--|
| <input type="checkbox"/> Domestic |  |  |
| <input type="checkbox"/> Others   |  |  |

This document is issued by the Company called TÜV SÜD Certification and Testing (China) Co., Ltd.. Attention is drawn to the limitation of liability, indemnification and jurisdiction issues defined therein. Any holder of this document is advised that information contained hereon is solely limited to visual examination of the safety and readily accessible portions of consignment and reflects the Company's findings at the time of its intervention only and within the limits of Client's instructions, if any. The company's sole responsibility is to its Client and this document does not exonerate parties to a transaction from exercising all their rights and obligations under the transaction document. Any unauthorized alteration, forgery or falsification of the content or appearance of this document is unlawful and offenders may be prosecuted to the fullest extent of the law..

Attention: To check the authenticity of testing/inspection report & certificate, please email: [info.MIC@tuv-sud.cn](mailto:info.MIC@tuv-sud.cn) or click: [www.tuv-sud.cn/mic-cn](http://www.tuv-sud.cn/mic-cn); [www.tuv-sud.cn/mic-en](http://www.tuv-sud.cn/mic-en)



### Section 3: Supplier Management

| 3.1 Supplier Management |  |   |
|-------------------------|--|---|
| Item                    | Content  | Observations /Comments  |
| 1                       | Does the company establish and implement an effective suppliers' assessment procedure? | <input checked="" type="checkbox"/> Have the written procedures and followed records<br><input type="checkbox"/> Have the written procedures but no records<br><input type="checkbox"/> Have relevant records without written procedure<br><input type="checkbox"/> No written procedures or followed records<br><input type="checkbox"/> Other |
| 2                       | Does the company have an updated list of approved suppliers?                           | <input checked="" type="checkbox"/> The approved suppliers list was updated in <u>2015</u><br><input type="checkbox"/> Have the written suppliers without approved signature or date.<br><input type="checkbox"/> Provided some suppliers names<br><input type="checkbox"/> No approved suppliers list<br><input type="checkbox"/> Other        |

### Section 4: After-sales Service Capacity

| 4.1 After-sales Service Capacity |  |  |
|----------------------------------|--|--|
| Item                             | Content  | Observations /Comments   |
| 1                                | Is there a procedure to conduct random product inspection after final packaging in place?  | <input checked="" type="checkbox"/> Have clear standards and written inspection records<br><input type="checkbox"/> No written standards but had inspection reports<br><input type="checkbox"/> Have the procedures but no inspection records<br><input type="checkbox"/> It's not necessary to carry out the inspection<br><input type="checkbox"/> Other |
| 2                                | Is there a clear procedure for handling customer complaints?   | <input checked="" type="checkbox"/> Has the clear procedure and followed records<br><input type="checkbox"/> Has the procedure but no written records.<br><input type="checkbox"/> No written procedures or records.<br><input type="checkbox"/> Other   |
| 3                                | Can the finished/packaged product be traced by lot identification to the appropriate raw materials test reports?   | <input checked="" type="checkbox"/> Have the procedures to trace the raw materials.<br><input type="checkbox"/> Can trace main materials<br><input type="checkbox"/> Can trace production date.<br><input type="checkbox"/> Can't trace products<br><input type="checkbox"/> Other   |
| 4                                | Are corrective & preventive actions mechanism established and implemented effectively (including the suppliers/ sub-contractors control, incoming inspection, process control, final inspection and customer complaint)? | <input checked="" type="checkbox"/> Has the clear procedure and followed records<br><input type="checkbox"/> Has the procedure but no written records.<br><input type="checkbox"/> No written procedures or records.<br><input type="checkbox"/> Other   |

This document is issued by the Company called TÜV SÜD Certification and Testing (China) Co., Ltd.. Attention is drawn to the limitation of liability, indemnification and jurisdiction issues defined therein. Any holder of this document is advised that information contained hereon is solely limited to the examination of the safety and readily accessible portions of consignment and reflects the Company's findings at the time of its intervention only and within the limits of Client's instructions, if any. The company's sole responsibility is to its Client and this document does not exonerate parties to a transaction from exercising all their rights and obligations under the transaction document. Any unauthorized alteration, forgery or falsification of the content or appearance of this document is unlawful and offenders may be prosecuted to the fullest extent of the law..

Attention: To check the authenticity of testing/inspection report & certificate, please email: [info.MIC@tuv-sud.cn](mailto:info.MIC@tuv-sud.cn) or click: [www.tuv-sud.cn/mic-cn](http://www.tuv-sud.cn/mic-cn); [www.tuv-sud.cn/mic-en](http://www.tuv-sud.cn/mic-en)



## Part D: Management System and Product Certification

| 1.1 Management System and Product Certification |  |
|---|--|
| Management system certification                 | <input type="checkbox"/> ISO9001:2008 certificate<br><input type="checkbox"/> ISO14001:2004 certificate<br><input type="checkbox"/> OHSAS18001:2007 certificate<br><input type="checkbox"/> TS16949<br><input type="checkbox"/> SA8000<br><input type="checkbox"/> Others<br><input checked="" type="checkbox"/> NIL   |
| Product certification                           | <input checked="" type="checkbox"/> CE<br>NO.: EC.1282.0D140418.ZFMQX64 Product Name: Mixer<br>Unit Model: SHR-10,SHR-25,SHR-100,SHR-200,SHR-300<br>Standard: EN ISO 12100:2010, EN 60204-1:2006+AC:2010<br>Issued by: ECM Issue Date: 01 Apr.,2014<br><br><input type="checkbox"/> UL<br><input type="checkbox"/> CCC<br><input type="checkbox"/> RoHS<br><input type="checkbox"/> FCC<br><input type="checkbox"/> Others<br><input type="checkbox"/> NIL |
| Test reports for raw materials                  | <input type="checkbox"/> RoHS<br><input type="checkbox"/> Reach<br><input type="checkbox"/> Others<br><input checked="" type="checkbox"/> NIL  |

This document is issued by the Company called TÜV SÜD Certification and Testing (China) Co., Ltd.. Attention is drawn to the limitation of liability, indemnification and jurisdiction issues defined therein. Any holder of this document is advised that information contained hereon is solely limited to the examination of the safety and readily accessible portions of consignment and reflects the Company's findings at the time of its intervention only and within the limits of Client's instructions, if any. The company's sole responsibility is to its Client and this document does not exonerate parties to a transaction from exercising all their rights and obligations under the transaction document. Any unauthorized alteration, forgery or falsification of the content or appearance of this document is unlawful and offenders may be prosecuted to the fullest extent of the law..

Attention: To check the authenticity of testing/inspection report & certificate, please email: [info.MIC@tuv-sud.cn](mailto:info.MIC@tuv-sud.cn) or click: [www.tuv-sud.cn/mic-cn](http://www.tuv-sud.cn/mic-cn); [www.tuv-sud.cn/mic-en](http://www.tuv-sud.cn/mic-en)





## Part E: Production Capacity & Quality Control



### Section 1: Production Capacity

#### 1.1 Production Workflow Chart

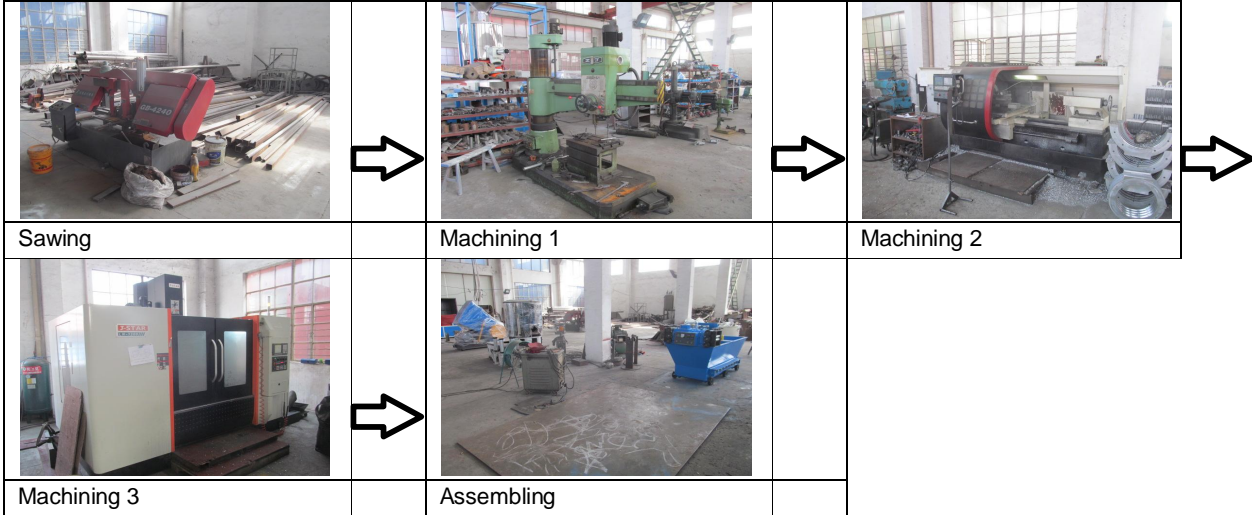
Production Workflow Chart Of



#### 1.2 Products Situation (Top Three Product Categories)

| Product  | Price range   | Min. order quantity | Top monthly output | Average monthly output | Total in |
|--|---------------|---------------------|--------------------|------------------------|----------|
| <br>Plastic Pipe Machine  | \$18000~10000 | 1set                | 2sets              | 1sets                  | 12sets   |
| <br>Waste Plastic Recycle | \$25000~4000  | 1set                | 2sets              | 1sets                  | 12sets   |
| <br>Waste Plastic Crusher | \$2000~20000  | 1set                | 8sets              | 3sets                  | 24sets   |







#### 1.3 Main Facilities

| Picture | Facility name | Brand or Country/Region of origin | Target Value/machine*day | Quantity |
|---------|---------------|-----------------------------------|--------------------------|----------|
|         |               |                                   |                          |          |

This document is issued by the Company called TÜV SÜD Certification and Testing (China) Co., Ltd.. Attention is drawn to the limitation of liability, indemnification and jurisdiction issues defined therein. Any holder of this document is advised that information contained hereon is solely limited to the examination of the safety and readily accessible portions of consignment and reflects the Company's findings at the time of its intervention only and within the limits of Client's instructions, if any. The company's sole responsibility is to its Client and this document does not exonerate parties to a transaction from exercising all their rights and obligations under the transaction document. Any unauthorized alteration, forgery or falsification of the content or appearance of this document is unlawful and offenders may be liable to criminal sanctions and/or civil damages to the fullest extent of the law..

Attention: To check the authenticity of testing/inspection report & certificate, please email: [info.MIC@tuv-sud.cn](mailto:info.MIC@tuv-sud.cn) or click: [www.tuv-sud.cn/mic-cn](http://www.tuv-sud.cn/mic-cn); [www.tuv-sud.cn/mic-en](http://www.tuv-sud.cn/mic-en)



|   |                  |                |                             |   |
|---|------------------|----------------|-----------------------------|---|
|    | Sawing Machine   | No Information | This data is not available. | 1 |
|    | Drilling Machine | No Information | This data is not available. | 3 |
|    | Shear Machine    | No Information | This data is not available. | 1 |
|    | Bending Machine  | No Information | This data is not available. | 1 |
|   | CNC Lathe 1      | No Information | This data is not available. | 1 |
|  | CNC Lathe 2      | No Information | This data is not available. | 2 |

This document is issued by the Company called TÜV SÜD Certification and Testing (China) Co., Ltd.. Attention is drawn to the limitation of liability, indemnification and jurisdiction issues defined therein. Any holder of this document is advised that information contained hereon is solely limited to visual examination of the safety and readily accessible portions of consignment and reflects the Company's findings at the time of its intervention only and within the limits of Client's instructions, if any. The company's sole responsibility is to its Client and this document does not exonerate parties to a transaction from exercising all their rights and obligations under the transaction document. Any unauthorized alteration, forgery or falsification of the content or appearance of this document is unlawful and offenders may be prosecuted to the fullest extent of the law..

Attention: To check the authenticity of testing/inspection report & certificate, please email: [info.MIC@tuv-sud.cn](mailto:info.MIC@tuv-sud.cn) or click: [www.tuv-sud.cn/mic-cn](http://www.tuv-sud.cn/mic-cn); [www.tuv-sud.cn/mic-en](http://www.tuv-sud.cn/mic-en)



## Section 2: Production Process Control

| 2.1 Production Process Control |   |   |
|--------------------------------|---|---|
| Item                           | Content   | Observations /Comments  |
| 1                              | Product R&D capacity  | <input checked="" type="checkbox"/> Own brand<br><input checked="" type="checkbox"/> ODM<br><input checked="" type="checkbox"/> OEM   |
| 2                              | Are the environmental conditions, such as tidiness and cleanliness being controlled and suitable for the operation performed? | <input type="checkbox"/> Very tidy<br><input checked="" type="checkbox"/> Normal<br><input type="checkbox"/> Need to improve<br><input type="checkbox"/> Very poor  |
| 3                              | Are the necessary items /documents provided at appropriate location and under control?  | <input checked="" type="checkbox"/> Work Instructions /procedures<br><input type="checkbox"/> Workmanship standard /acceptance<br><input type="checkbox"/> Golden sample /Approval sample<br><input type="checkbox"/> Product picture<br><input type="checkbox"/> Verbal by workshop director                       |
| 4                              | Are written instructions available for incoming material inspections /testing?<br>Is the relevant record maintained?          | <input checked="" type="checkbox"/> Has instructions and uniformly followed<br><input type="checkbox"/> Has instruction but no written records<br><input type="checkbox"/> Materials checked by storage staff   |
| 5                              | Are written inspections /testing instructions available for finished products?<br>Is the relevant record maintained?          | <input checked="" type="checkbox"/> Have instructions and uniformly followed<br><input type="checkbox"/> Have instruction but no written records<br><input type="checkbox"/> Finished product checked by packing staff  |
| 6                              | What type of inspection is used for finished products?  | <input type="checkbox"/> Random inspection<br><input type="checkbox"/> Visual inspection<br><input type="checkbox"/> Function inspection<br><input checked="" type="checkbox"/> 100% inspection<br><input checked="" type="checkbox"/> Visual inspection<br><input checked="" type="checkbox"/> Function inspection |
| 7                              | Are non-conforming units clearly marked/ segregated to prevent accidental dispatch?   | <input checked="" type="checkbox"/> Marked and segregated<br><input type="checkbox"/> Segregated but not marked clearly<br><input type="checkbox"/> Not found on site   |
| 8                              | How are the non-conforming units handled?   | <input checked="" type="checkbox"/> Repaired and re-inspection<br><input type="checkbox"/> Picked out<br><input type="checkbox"/> Used under control<br><input type="checkbox"/> Others   |

This document is issued by the Company called TÜV SÜD Certification and Testing (China) Co., Ltd.. Attention is drawn to the limitation of liability, indemnification and jurisdiction issues defined therein. Any holder of this document is advised that information contained hereon is solely limited to visual examination of the safety and readily accessible portions of consignment and reflects the Company's findings at the time of its intervention only and without limits of Client's instructions, if any. The company's sole responsibility is to its Client and this document does not exonerate parties to a transaction from exercising all their rights and obligations under the transaction document. Any unauthorized alteration, forgery or falsification of the content or appearance of this document is unlawful and offenders may be liable to criminal sanctions and/or civil damages to the best extent of the law..

Attention: To check the authenticity of testing/inspection report & certificate, please email: [info.MIC@tuv-sud.cn](mailto:info.MIC@tuv-sud.cn) or click: [www.tuv-sud.cn/mic-cn](http://www.tuv-sud.cn/mic-cn); [www.tuv-sud.cn/mic-en](http://www.tuv-sud.cn/mic-en)





**Part J: Photos**

**Section 1: Photos of Documents**

| 1.1 Photos of Documents                                |   |
|--|---|
| <b>Description: Business License</b>                   | <b>Description: Import and Export Enterprise Registration</b> |
|  |   |
| <b>Description: Certificate of land 1</b>              | <b>Description: Certificate of land 2</b>                     |
|  |   |
| <b>Description: Custom Clearance Registration Form</b> | <b>Description: CE Certification</b>                          |
|  |   |

This document is issued by the Company called TÜV SÜD Certification and Testing (China) Co., Ltd.. Attention is drawn to the limitation of liability, indemnification and jurisdiction issues defined therein. Any holder of this document is advised that information contained hereon is solely limited to a visual examination of the safety and readily accessible portions of consignment and reflects the Company's findings at the time of its intervention only and within the limits of Client's instructions, if any. The company's sole responsibility is to its Client and this document does not exonerate parties to a transaction from exercising all their rights and obligations under the transaction document. Any unauthorized alteration, forgery or falsification of the content or appearance of this document is unlawful and offenders may be liable to criminal sanctions and/or civil penalties in the best extent of the law..

Attention: To check the authenticity of testing/inspection report & certificate, please email: [info.MIC@tuv-sud.cn](mailto:info.MIC@tuv-sud.cn) or click: [www.tuv-sud.cn/mic-cn](http://www.tuv-sud.cn/mic-cn); [www.tuv-sud.cn/mic-en](http://www.tuv-sud.cn/mic-en)



**Description: Trademark**



This document is issued by the Company called TÜV SÜD Certification and Testing (China) Co., Ltd.. Attention is drawn to the limitation of liability, indemnification and jurisdiction issues defined therein. Any holder of this document is advised that information contained hereon is solely limited to the examination of the safety and readily accessible portions of consignment and reflects the Company's findings at the time of its intervention only and within the limits of Client's instructions, if any. The company's sole responsibility is to its Client and this document does not exonerate parties to a transaction from exercising all their rights and obligations under the transaction document. Any unauthorized alteration, forgery or falsification of the content or appearance of this document is unlawful and offenders may be liable to criminal sanctions and/or civil damages in the best extent of the law..

Attention: To check the authenticity of testing/inspection report & certificate, please email: [info.MIC@tuv-sud.cn](mailto:info.MIC@tuv-sud.cn) or click: [www.tuv-sud.cn/mic-cn](http://www.tuv-sud.cn/mic-cn); [www.tuv-sud.cn/mic-en](http://www.tuv-sud.cn/mic-en)





## Section 2: Photos of Company

### 2.1 Photos of Company and Product Sample

Description: Company Gate



Description: Plant



Description: Office 1



Description: Office 2



Description: Meeting room



Description: Workshop 1



Description: Workshop 2



Description: Product sample 1

This document is issued by the Company called TÜV SÜD Certification and Testing (China) Co., Ltd.. Attention is drawn to the limitation of liability, indemnification and jurisdiction issues defined therein. Any holder of this document is advised that information contained hereon is solely limited to the examination of the safety and readily accessible portions of consignment and reflects the Company's findings at the time of its intervention only and within the limits of Client's instructions, if any. The company's sole responsibility is to its Client and this document does not exonerate parties to a transaction from exercising all their rights and obligations under the transaction document. Any unauthorized alteration, forgery or falsification of the content or appearance of this document is unlawful and offenders may be prosecuted to the fullest extent of the law..

Attention: To check the authenticity of testing/inspection report & certificate, please email: [info.MIC@tuv-sud.cn](mailto:info.MIC@tuv-sud.cn) or click: [www.tuv-sud.cn/mic-cn](http://www.tuv-sud.cn/mic-cn); [www.tuv-sud.cn/mic-en](http://www.tuv-sud.cn/mic-en)





Description: Product sample 2



Description: Product sample 3



Description: Product sample 4



Description: Product sample 6



Description: Product sample 5



Description: Product sample 7

This document is issued by the Company called TÜV SÜD Certification and Testing (China) Co., Ltd.. Attention is drawn to the limitation of liability, indemnification and jurisdiction issues defined therein. Any holder of this document is advised that information contained hereon is solely limited to visual examination of the safety and readily accessible portions of consignment and reflects the Company's findings at the time of its intervention only and within the limits of Client's instructions, if any. The company's sole responsibility is to its Client and this document does not exonerate parties to a transaction from exercising all their rights and obligations under the transaction document. Any unauthorized alteration, forgery or falsification of the content or appearance of this document is unlawful and offenders may be liable to criminal sanctions and/or civil damages to the fullest extent of the law..

Attention: To check the authenticity of testing/inspection report & certificate, please email: [info.MIC@tuv-sud.cn](mailto:info.MIC@tuv-sud.cn) or click: [www.tuv-sud.cn/mic-cn](http://www.tuv-sud.cn/mic-cn); [www.tuv-sud.cn/mic-en](http://www.tuv-sud.cn/mic-en)





Description: Product sample 8



Description: Product sample 9



-- End of the Report --

This document is issued by the Company called TÜV SÜD Certification and Testing (China) Co., Ltd.. Attention is drawn to the limitation of liability, indemnification and jurisdiction issues defined therein. Any holder of this document is advised that information contained hereon is solely limited to visual examination of the safety and readily accessible portions of consignment and reflects the Company's findings at the time of its intervention only and within the limits of Client's instructions, if any. The company's sole responsibility is to its Client and this document does not exonerate parties to a transaction from exercising all their rights and obligations under the transaction document. Any unauthorized alteration, forgery or falsification of the content or appearance of this document is unlawful and offenders may be liable to criminal sanctions and/or civil damages to the best extent of the law..

Attention: To check the authenticity of testing/inspection report & certificate, please email: [info.MIC@tuv-sud.cn](mailto:info.MIC@tuv-sud.cn) or click: [www.tuv-sud.cn/mic-cn](http://www.tuv-sud.cn/mic-cn); [www.tuv-sud.cn/mic-en](http://www.tuv-sud.cn/mic-en)