



DENTAL CHAIR

unparalleled quality

美国 FDA 欧盟 CE MDR ISO13485 认证



ADENG™

Global standard

让每一位使用者都能够自信操作，让每一位治疗者体验舒适治疗！
用心，是每一位制造商的初心；
--- 不浮夸、不做作、不将就；
客户满意，是我们作为最终追求的且愿意奉献的精神动力。

Enabling every user to operate with confidence and allowing every therapist to experience comfortable and dedicated treatment is the original intention of every manufacturer;

We are not extravagant, pretentious, or compromising;

Customer satisfaction is our ultimate pursuit and the driving force behind our dedication.



Company Profile 公司简介

广东雅登医疗器械有限公司是一家致力于提供优质服务，集研发、制造、营销于一体的医疗器械设备专业制造与服务商，主营产品有：联体式牙科综合治疗机、抽吸系统、供气系统等口腔用医疗器械，同时代理销售国内外相关医疗器械产品；我们不断追求卓越、以客户为中心，为合作伙伴提供专业、高效的产品配套方案。

核心实力与生产保障

企业配备专业人力资源团队，具备成熟技术能力以及完善的售后服务团队，拥有约 8000 平方米标准化生产和制造基地，可稳定保障产品生产交付与售后服务开展；公司已具备完整生产制造系统，涵盖五金车间、注塑车间、PU 加工车间、烤漆车间及产品组装车间检测车间，通过规范的设备制造流程把控产品质量，为品质提升提供多环节支撑和保障。

市场布局与服务能力

企业业务覆盖多个国家和地区，专业销售团队与服务网络遍布国内外大中小城市，服务触达范围广泛；我们同时拥有专业销售与售后团队，为客户提供全流程针对性服务，覆盖售前咨询、售中配合与售后维护等环节。

资质认证与合规保障

企业已取得按照国内注册最新政策标准获得企业三证，同时通过了欧盟 ISO 13485 医疗器械国际质量体系认证和最新 CE MDR 认证证书及美国 FDA 认证证书，成为了国内牙科行业为数不多的三个认证企业；多维度认证体系可满足不同国家和地区的市场准入要求，为客户提供合规层面的品质保障。

合作愿景

公司诚挚希望与全球客户建立长期友好的互利合作关系，通过业务往来与技术交流，携手开发医疗器械产业发展机遇，实现互利共赢、协同发展。

Guangdong Yadeng Medical Apparatus Co., Ltd. is a professional manufacturer and service provider of medical equipment, dedicated to providing high-quality services and integrating R&D, manufacturing, and marketing. Our main products include integrated dental treatment units, suction systems, and air supply systems for oral care. We also act as an agent for the sale of related medical equipment products from both domestic and international manufacturers. We constantly strive for excellence and are customer-centric, providing our partners with professional and efficient product solutions.

Core Strengths and Production Guarantee

The company is equipped with a professional human resources team, mature technical capabilities, and a comprehensive after-sales service team. It possesses approximately 8,000 square meters of standardized production and manufacturing facilities, ensuring stable product production, delivery, and after-sales service. The company has a complete manufacturing system, including metalworking workshops, injection molding workshops, PU processing workshops, painting workshops, and product assembly and testing workshops. Through standardized equipment manufacturing processes, the company controls product quality, providing multi-faceted support and guarantees for quality improvement.

Market Presence and Service Capabilities

Our company's business covers multiple countries and regions, with a professional sales team and service network spanning large, medium, and small cities both domestically and internationally, ensuring a wide service reach. We also have a professional sales and after-sales team to provide customers with comprehensive, tailored services throughout the entire process, covering pre-sales consultation, in-sales support, and after-sales maintenance.

Qualifications and Compliance Assurance

The company has obtained the three required business licenses in accordance with the latest domestic registration policies and standards. It has also obtained the EU ISO 13485 international quality system certification for medical devices, the latest CE MDR certification, and US FDA certification, becoming one of the few companies in the domestic dental industry to hold these three certifications. This multi-dimensional certification system meets market access requirements in different countries and regions, providing customers with quality assurance from a compliance perspective.

Cooperation Vision

Our company sincerely hopes to establish long-term, friendly, and mutually beneficial cooperative relationships with global customers. Through business interactions and technical exchanges, we aim to jointly develop opportunities in the medical device industry, achieving mutual benefit and collaborative development.

Enterprise qualification 企业资质

国内三证 Domestic certificates



欧盟 ISO



欧盟 CE MDR



美国 FDA



YD-A1 星耀 26 款





段落式器械盘

超大置物台面，挂架位可 30°转动角度，同时配备全覆盖式透明塑料垫，有效防止液体洒落

Wide Design Instrument Tray

Large storage area, equipped with a covered transparent plastic cover to effectively prevent liquid spills; The hanger position can be rotated 30°.



90°旋转侧箱

侧箱采用注塑工艺，可 90°旋转，释放助手操作空间

90° Rotating Side Box

The side box is made using injection molding technology, and the box body can be rotated 90°, facilitating four-handed operation.



皮垫压边车线工艺

皮垫采用压边车线工艺，更加时尚美观

Leather Cushion with Edge Stitching Process

The dental chair's leather cushion utilizes an edge stitching process, resulting in a stronger three-dimensional effect, enhanced durability, and a premium feel.

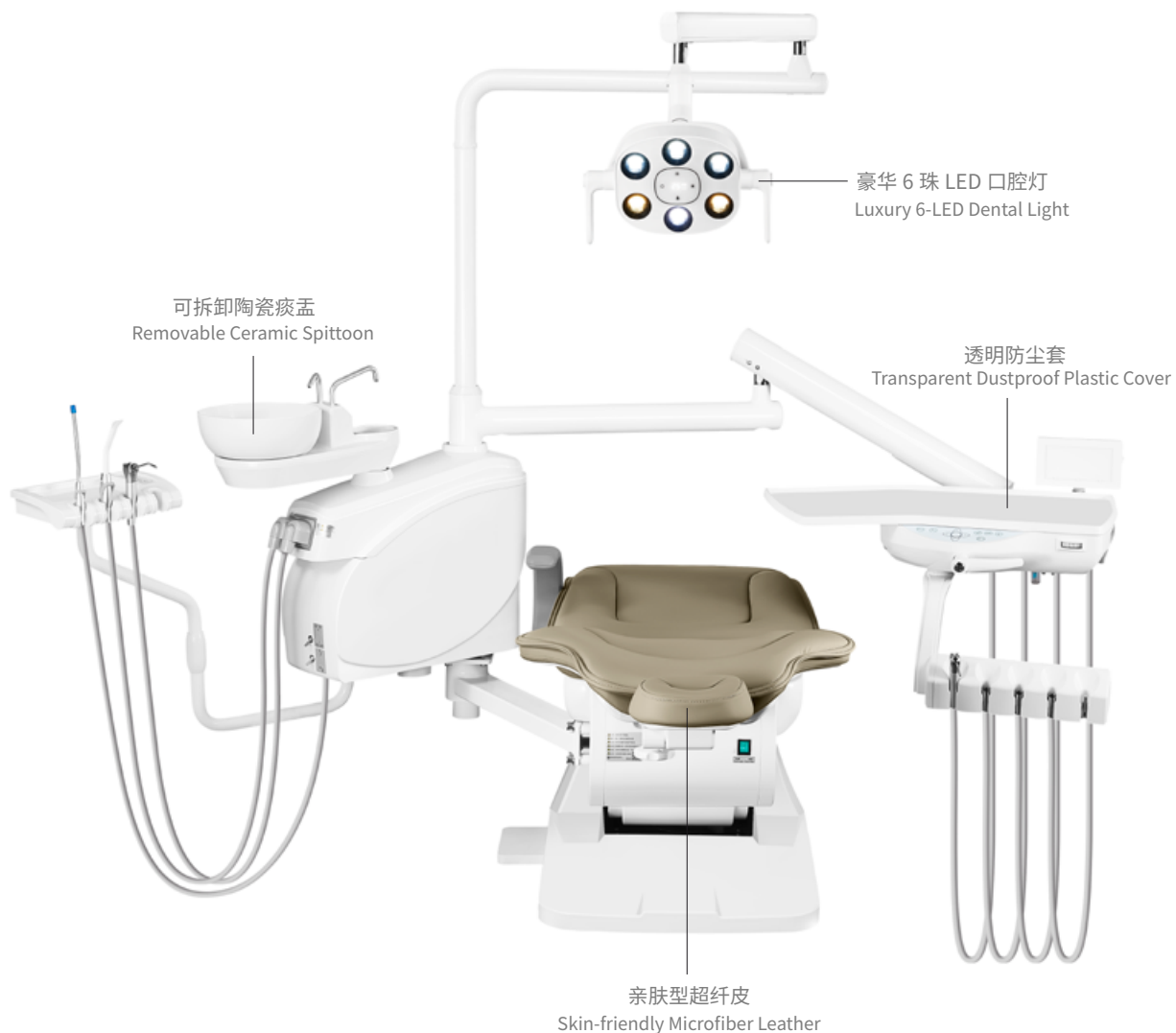

选购件 Accessories

序号 No	数量 Qty	名称
1	1	进口 NSK 高低速手机 Imported NSK high and low speed handpiece
2	1	国产高低速手机 China high and low-speed handpiece
3	1	啄木鸟内置 N2LED 洁牙机 Wood pecker N2 LED Ultrasonic scaler
4	1	啄木鸟内置 G/Q 型光固化 Woodpecker G/Q Curing light
5	1	内窥镜系统 Intra oral camera
6	1	静音无油空压机 Silent oil-free air compressor
7	1	负压抽吸系统 Suction pump system
8	1	上挂器械盘 Top mounted tool tray
9	1	超纤皮、真皮皮垫 Micro fiber/genuine leather
10	1	升降小推车 Lifting trolley
11	1	不锈钢托盘组件 Stainless steel pallet assembly
12	1	无影灯 Shadowless lamp
13	1	内置电动马达、洁牙机控制液晶屏 Built-in electric motor with LCD display



AD-S 系列皮垫颜色 AD-S Series of leather pad colors

进口亲肤皮 Imported skin-friendly leather



超纤皮 Microfiber leather

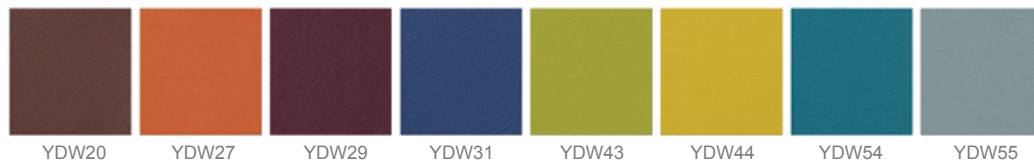

PU 皮 PU skin

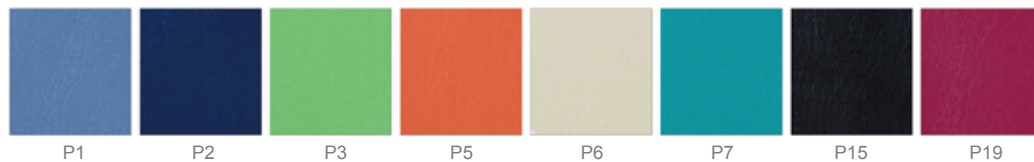

YD-A 系列皮垫颜色 YD-A Series of leather pad colors

国产亲肤皮 Domestic skin-friendly leather

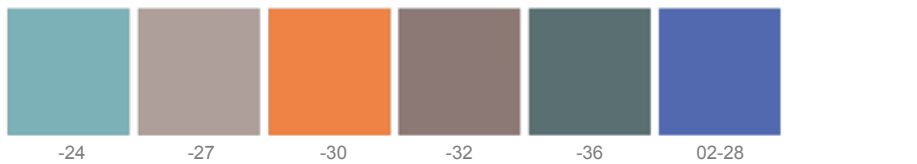
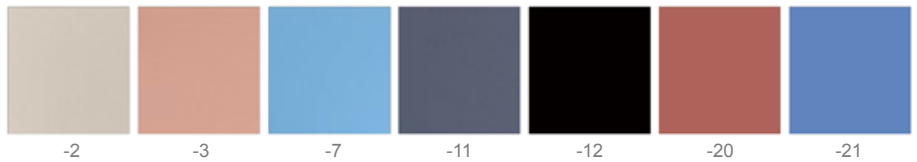

PU 皮 PU skin

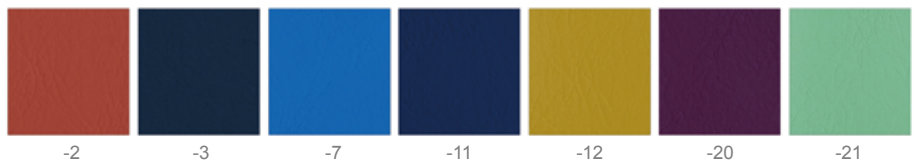

技术规格和参数 Technical specifications and parameters

名称 Name	数量单位 Unit of quantity	型号 Model	AD-S1	AD-S3	AD-S6 (26)	AD-S6 (25)	YD-A1	YD-A2	YD-A3	YD-A4 (26)	YD-A4 (25)	YD-A5
联动补偿椅位 Linkage compensation chair	1台 1 Taiwan		√	√	√	√	×	×	×	√	√	×
进口直流电机 Imported DC motor	2个 2 Number		√	√	√	√	√	√	√	√	√	√
进口电磁阀 Imported solenoid valve	2个 2 Number		√	√	√	√	×	×	×	√	√	×
三用枪冷/热 Three-in-one gun, cold/hot	2把 2 Count		√	√	√	√	√	√	√	√	√	√
进口亲肤皮 Imported skin-friendly leather	1套 1 Set of		×	√	√	√	×	×	×	×	×	×
超纤皮 Microfiber leather	1套 1 Set of		√	×	×	×	×	×	×	×	×	×
国产亲肤皮 Domestic skin-friendly leather / PU	1套 1 Set of		×	×	×	×	√	√	√	√	√	√
皮垫记忆棉 Leather pad memory foam	1套 1 Set of		√	√	√	√	×	×	×	×	×	×
主、副控制系统 Main and auxiliary control	1套 1 Set of		√	√	√	√	√	√	√	√	√	√
强弱吸系统 Strong and weak suction system	1套 1 Set of		√	√	√	√	√	√	√	√	√	√
纯净水系统 Pure water system	1套 1 Set of		√	√	√	√	√	√	√	√	√	√
机椅互锁功能 Interlocking function between the machine and the chair	1套 1 Set of		√	√	√	√	×	×	×	√	√	×
供水系统 Water supply system	1套 1 Set of		√	√	√	√	√	√	√	√	√	√
六合一脚踏 Six steps in one	1套 1 Set of		√	√	√	√	√	√	√	√	√	√
标准式口腔灯 6-12孔 Standard oral lamp with 6 to 12 holes	1个 1 Number		√	√	×	√	√	√	√	√	√	√
无影灯 Shadowless lamp	1个 1 Number		×	×	√	×	×	×	×	×	×	×
9个记忆功能 Nine memory functions	1套 1 Set of		√	√	√	√	×	×	×	√	√	×
铸铝机箱架 Cast aluminum chassis frame	1套 1 Set of		√	√	×	×	×	×	×	×	×	×
医用液晶控制屏 Medical LCD control screen	1块 1 block		√	√	√	√	×	×	√	√	√	×
医生椅 + 护士椅 Doctor's chair + nurse's chair	2张 2 block		√	√	√	√	×	√	√	√	√	×

名称 Name	数量单位 Unit of quantity	型号 Model	AD-S1	AD-S3	AD-S6 (26)	AD-S6 (25)	YD-A1	YD-A2	YD-A3	YD-A4 (26)	YD-A4 (25)	YD-A5
腰枕 + 头枕 Lumbar pillow + headrest	1套 1 Set of		√	√	√	√	×	√	√	√	√	×
靠背坐垫按摩加热功能 Backrest cushion massage heating function	1套 1 Set of		×	√	√	√	×	×	×	×	×	×
豪华铝双控多角度枕头架 Luxurious aluminum dual-control multi-angle pillow	1套 1 Set of		√	√	√	√	×	×	×	√	√	×

基本参数:

1	电流电压 Power voltage	AC220V±10V, 50Hz/60Hz
2	直流电机 DC motor	24V
3	气源压力 Air pressure	> 0.5MPa
4	水源压力 Water pressure	0.2MPa-0.4MPa
5	口腔灯照度 Illumination	8000Lux-45000Lux
6	观片灯亮度 Lighting power	≥ 2000FL
7	环境温度 Ambient temperature	5°C~ 40°C
8	相对湿度 Relative humidity	≤ 80% RH
9	大气压力 Atmospheric pressure	86kPa ~ 106kPa
10	机身偏斜 Body deflection	≤ 0.1°



吊顶支架 Ceiling Type Single Head

安装示意图 Installation Diagram

牙科诊室管路布置及空间要求: Dental clinic piping layout and space requirements:

- 1、供水 / 供气管: PPR 热熔管, 预留 4 分铜内牙接口;
Water supply/gas supply pipe: PPR hot melt pipe, with 4 points of copper internal tooth interface reserved;
- 2、排污管: PVC 排水管, 主管 $\geq 75\text{MM}$, 支管 50MM;
Sewage pipe: PVC drainage pipe, main pipe $\geq 75\text{MM}$, branch pipe 50MM;
- 3、VGA 视频及 USB 数据线管 (如有需要): PVC 穿线管 $\geq 32\text{MM}$, 可备用一条后期维修使用;
VGA video and USB data cable tube (if necessary): PVC threading tube $\geq 32\text{MM}$, a spare one can be used for later maintenance;
- 4、电动负压管: UPVC 给水管, 主管道 50MM, 支管 32MM, 接入牙椅管 25MM;
Electric negative pressure pipe: UPVC water supply pipe, main pipe 50MM, branch pipe 32MM, connected to the dental chair pipe 25MM;
- 5、电动负压信号线 / 输入电源线: PVC 穿线管, 4 分管套 $2 \times 1.5 \text{ m}^2$ 线;
Electric negative voltage signal line/input power line: PVC threading pipe, 4-piece pipe set with $2 \times 1.5 \text{ m}^2$ wire;

注意事项: 排水管和负压接管处不能用直角接头, 应该用 45° 接头; 供水供气要预留独立开关。

Note: Right-angle joints cannot be used for drainage pipes and negative pressure pipes, and 45° joints should be used; independent switches should be reserved for water and gas supply.

供水供气要预留独立开关。

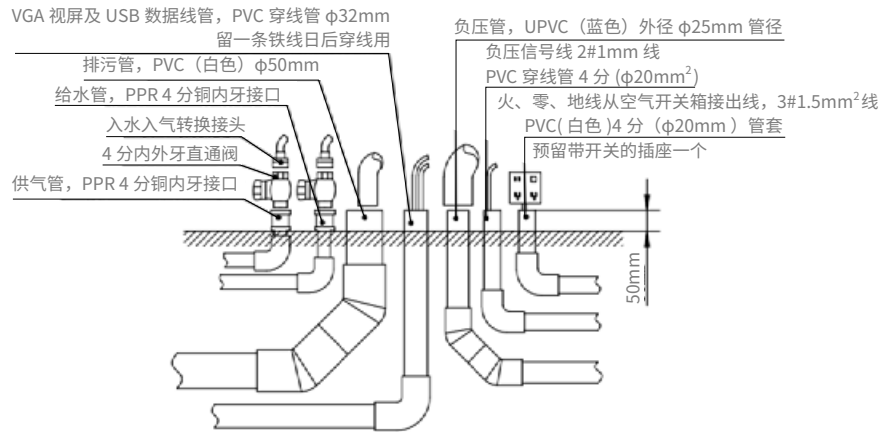

施工图
working drawing

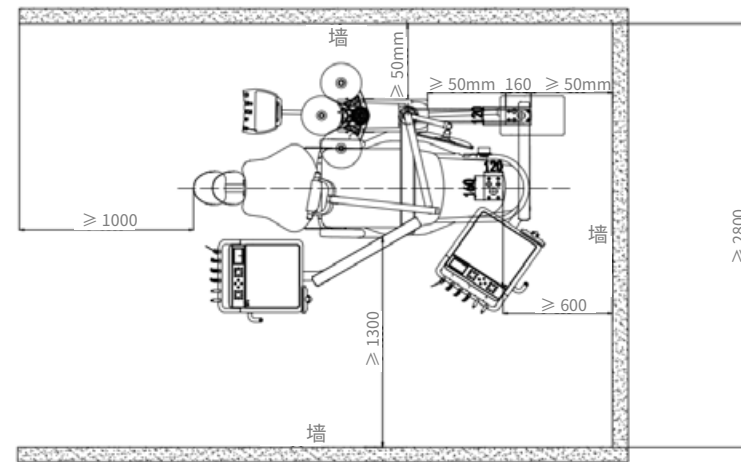

牙椅长高尺寸图

Height dimension diagram of dental chair

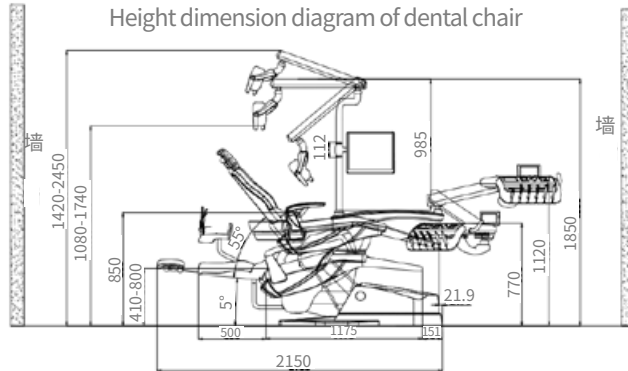

牙椅宽度尺寸图

Tooth chair width dimension diagram

