

Product Description

- ◆ MOSFET Output
- ◆ Low Impedance
- ◆ Control Voltage: 4-15VDC or 15-32VDC
- ◆ Internal Over-voltage Protection
- ◆ Photoelectric Isolation
- ◆ Dielectric Strength: 2500Vrms
- ◆ Panel Mount
- ◆ LED Indicator
- ◆ RoHS Compliant



Ordering Information

<b>KSJB</b>	<b>30</b>	<b>LD</b>	<b>10</b>	<b>(XXX)</b>
KSJB Series <sup>(1)</sup>	Load Voltage 30:0-24VDC 50:0-36VDC 60:0-48VDC 100:0-75VDC 200:0-120VDC	Control Voltage LD: 4-15VDC HD: 15-32VDC	Load Current 10:10Amp 20:20Amp 40:40Amp 50:50Amp	Customized Code

(1) Part numbers available are listed in the table below.

	30VDC	50VDC	60VDC	100VDC	200VDC
10A			KSJB60LD10 KSJB60HD10		KSJB200LD10 KSJB200HD10
20A				KSJB100LD20 KSJB100HD20	
40A		KSJB50LD40 KSJB50HD40		KSJB100LD40 KSJB100HD40	
50A	KSJB30LD50 KSJB30HD50				

General Specifications

Input Specifications (Ta=25°C)		
Control Voltage Range	LD	4-15VDC
	HD	15-32VDC
Must Turn-on Voltage	LD	4VDC
	HD	15VDC
Must Turn-off Voltage		2VDC
Maximum Input Current	LD	25mA (@15VDC)
	HD	25mA (@32VDC)
Maximum Reverse Voltage	LD	15VDC
	HD	32VDC

**General Specifications**

Output Specifications (Ta=25°C)						
Ordering Information	KSJB30...50	KSJB50...40	KSJB60...10	KSJ100...20	KSJB100...40	KSJB200...10
Transistor Voltage(VDC)	55	75	100	150	150	250
Load Voltage Range (VDC)	0-24	0-36	0-48	0-75	0-75	0-120
TVS Breakdown Voltage Scope(V)	37.1-41	53.2-58.8	64.6-71.4	105-116	105-116	190-210
Maximum Load Current (A)	50	40	10	20	40	10
Maximum Surge Current(Apk.@10ms)	150	120	30	60	120	30
Maximum On-State Resistance (mΩ)	4.2	12	12	6.2	6.2	60
Maximum Off-State Leakage Current @Rated Load Voltage (mA)	0.1					
Minimum Load Current (mA)	2					
Maximum Turn-on Time (ms)	0.3					
Maximum Turn-off Time (ms)	0.3					

General Specifications (Ta=25°C)		
Dielectric Strength (50/60Hz)	Input/Output	2500Vrms
	Input, output/Base	2500Vrms
Minimum Insulation Resistance (@500VDC)	1000MΩ	
Ambient Temperature Range	-30°C ~ +80°C	
Storage Temperature Range	-30°C ~ +100°C	
Weight (Typical)	150g	

**Applications**

DC heating, DC power supply, DC valve, DC motor, medical equipment, etc.

**Outline Dimensions**

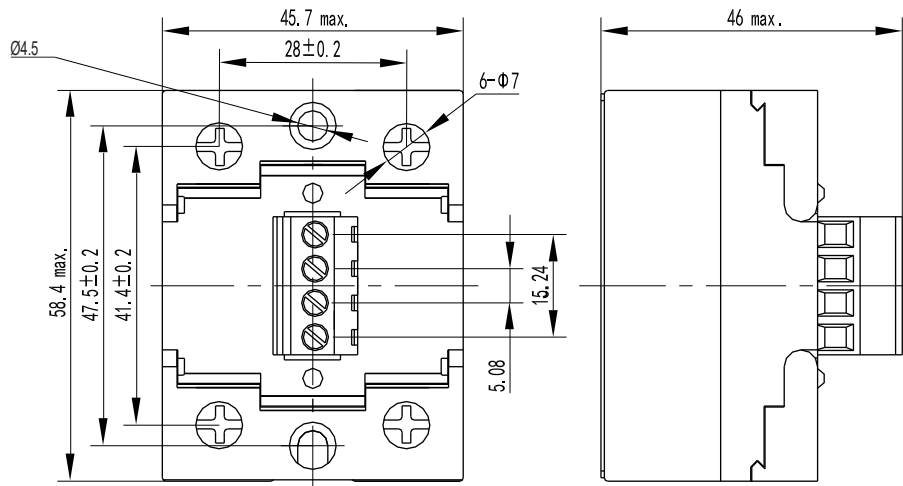

Wiring Diagram

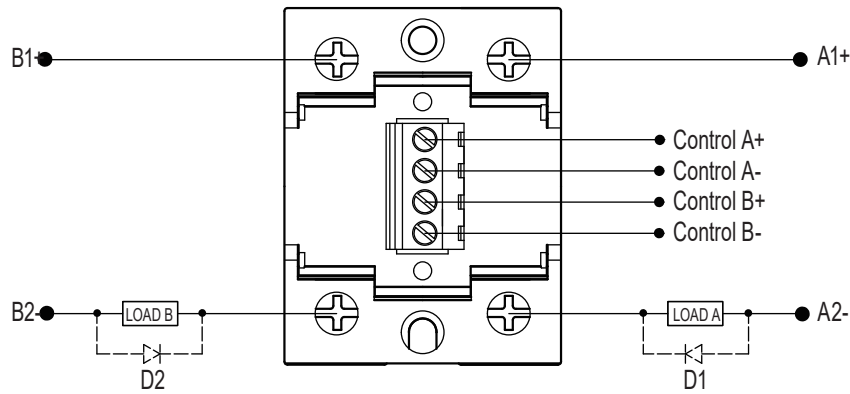

When the relay is used for inductive load control, please be sure to use a suppression circuit, just like the drawing above.  
Both load terminals are inverse parallelled with fly-wheel diodes D1, D2 .  
D1, D2: Fast Recovery Diode

Thermal Derating Curve

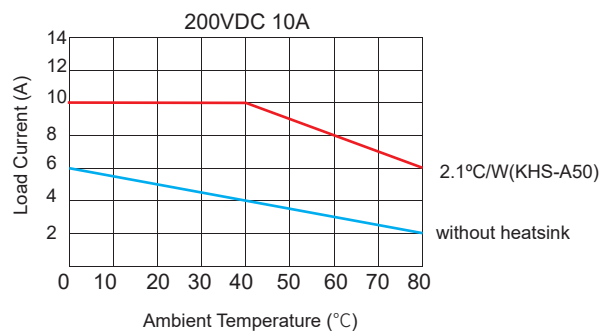
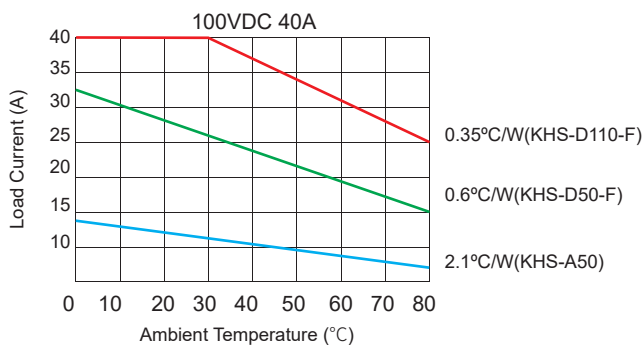
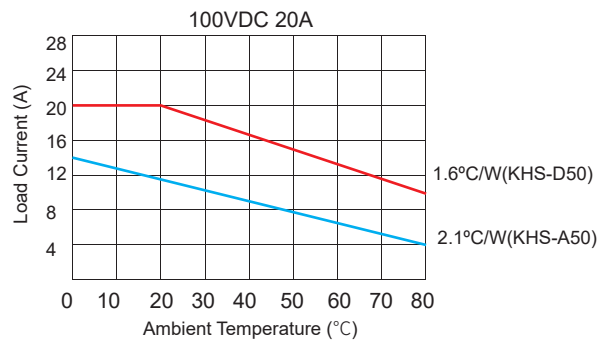
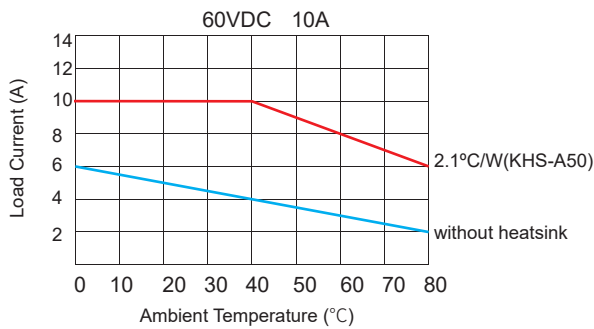
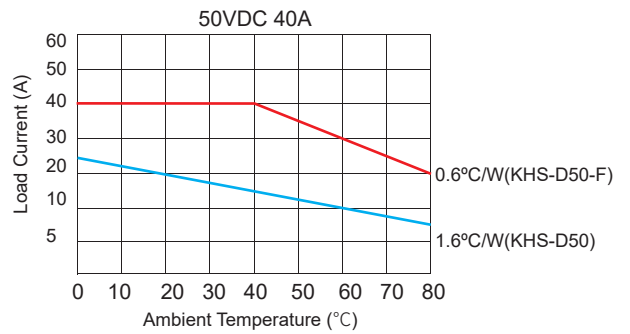
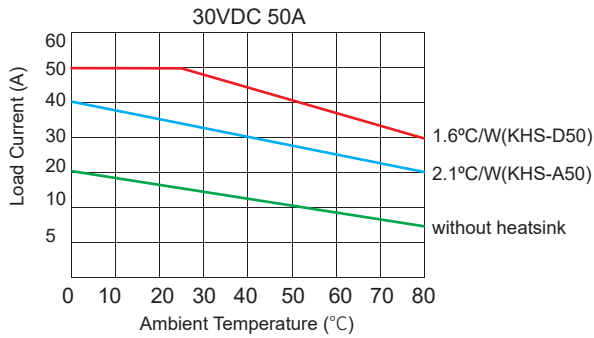

The above temperature curve is configured with heatsink models as follows:

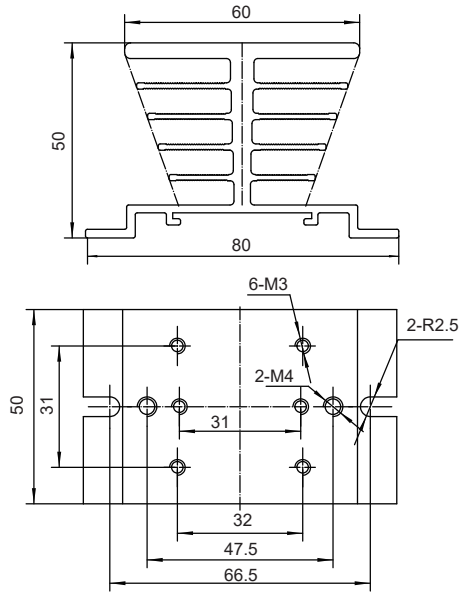

KHS-A50

(Note: The recommended mounting hole size is 68mm)

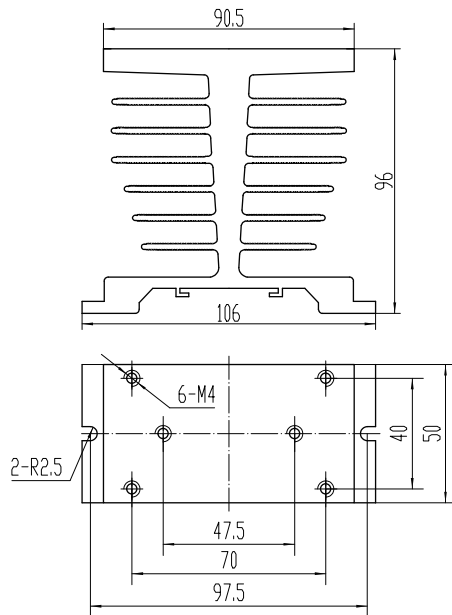

KHS-D50

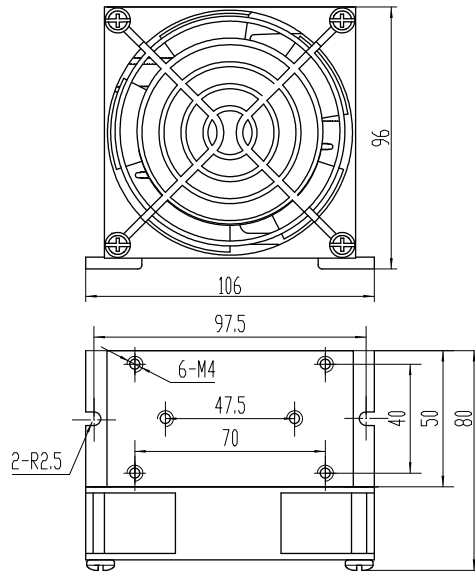

KHS-D50-F

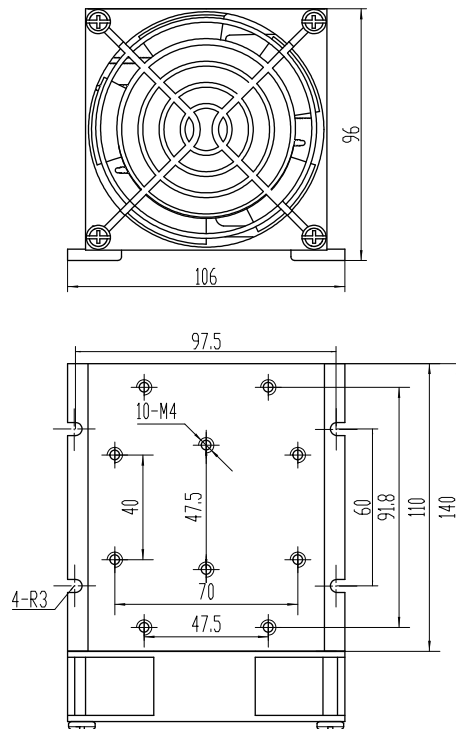

KHS-D110-F

## General Notes

- 1.The heat generated by the relay needs to be dissipated through the bottom plate, and it is necessary to ensure that the relay base plate is in close contact with the heat sink and installed firmly, and the contact surface needs to be covered with thermal pad or thermal grease.
- 2.The relay terminal should ensure that the wiring is firm because the loose wiring will cause the product to heat up abnormally and damage the product. The recommended installation torque for M3 terminals is (0.2~0.5)N·m, and for M4 terminals the recommended installation torque is (0.98~1.37) N·m.
- 3.When the ambient temperature is high, please refer to the temperature curve to derate.
- 4.For the capacitive load, at the moment of turning on, an extremely high inrush current will happen, which may cause SSR to be damaged due to excessive inrush current. Therefore, if the load is a capacitive load, or if the load is equipped with a large capacitor in parallel, it is strongly recommended to connect the NTC in series in the load circuit to suppress the inrush current to avoid damage to the product.

## ! Warnings

1. The product's side panels may be hot, allow the product to cool before touching.
2. Disconnect all power before installing or working with this equipment.
3. Verify all connections and replace all covers before turning on power.