

Product Description

- ◆ Zero-crossing or Random-on Switching
- ◆ TRIAC Output
- ◆ DC Input
- ◆ Dielectric Strength: 4000Vrms
- ◆ Load Current: 10A, 16A, 25A
- ◆ Internal RC/MOV, TVS Protection Circuit
- ◆ LED Indicator
- ◆ Protective cover KPC-2A (Optional)

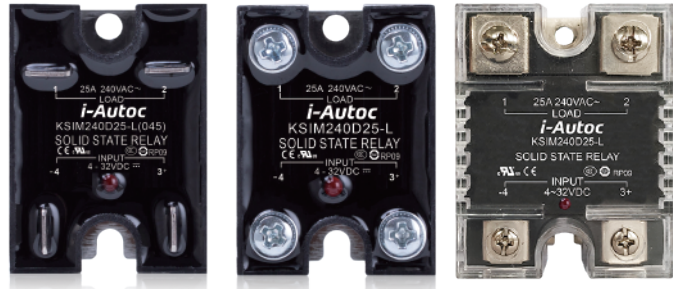

Note: No CCC approval for TVS products.

Ordering Information

KSIM	240	D	25	R	-L	M	(XXX)
KSIM Series	Load Voltage 240: 240VAC 380: 380VAC	Control Mode D: DC Control	Load Current 10: 10Amp 16: 16Amp 25: 25Amp	Switching Mode Blank: Zero Crossing R: Random-on	LED Indicator	M: MOV Protection T: TVS (Optional)	Customized Code 045: Quick Connection 117: Quick Connection 198: Quick Connection

	10A	16A	25A
240	KSIM240D10-L	KSIM240D16-L	KSIM240D25-L
	KSIM240D10-LM	KSIM240D16-LM	KSIM240D25-LM
	KSIM240D10-LT	KSIM240D16-LT	KSIM240D25-LT
	KSIM240D10R-L	KSIM240D16R-L	KSIM240D25R-L
	KSIM240D10R-LM	KSIM240D16R-LM	KSIM240D25R-LM
380	KSIM240D10R-LT	KSIM240D16R-LT	KSIM240D25R-LT
	KSIM380D10-L	KSIM380D16-L	KSIM380D25-L
	KSIM380D10-LM	KSIM380D16-LM	KSIM380D25-LM
	KSIM380D10-LT	KSIM380D16-LT	KSIM380D25-LT
	KSIM380D10R-L	KSIM380D16R-L	KSIM380D25R-L
	KSIM380D10R-LM	KSIM380D16R-LM	KSIM380D25R-LM
	KSIM380D10R-LT	KSIM380D16R-LT	KSIM380D25R-LT

General Specifications

Input Specifications (Ta=25°C)	
Control Voltage Range	4-32VDC
Must Turn-on Voltage	4VDC
Must Turn-off Voltage	1VDC
Maximum Input Current	25mA

Output Specifications (Ta=25°C)		
Load Voltage Range	240VAC	24-280VAC
	380VAC	24-440VAC
Maximum 1 Cycle Surge Current (@10ms)	10A	120A
	16A	160A
	25A	250A
I ² T	10A	50A ² S
	16A	128A ² S
	25A	312A ² S
Maximum Turn-on Time	Random-on	1ms
	Zero Crossing	10ms
Maximum Turn-off Time		10ms

General Specifications

Output Specifications (Ta=25°C)		
Transient Overvoltage	240VAC	600Vpk
	380VAC	800Vpk
Maximum Off-State Leakage Current@Rated Load Voltage	5mA	
Maximum On-State Voltage Drop@Rated Current	1.5Vrms	
Minimum Off-State dv/dt@Maximum Rated Voltage	200V/μs	
Maximum di/dt Non Repetitive	50A/μs	
Frequency Range	47Hz ~ 63Hz	

General Specifications (Ta=25°C)		
Dielectric Strength (50/60Hz)	Input/Output	4000Vrms
	Input, output/Base	2500Vrms
Minimum Insulation Resistance (@500VDC)	1000MΩ	
Power Factor	>0.5	
Ambient Temperature Range	-30°C ~ +80°C	
Storage Temperature Range	-30°C ~ +100°C	
Weight (Typical)	35g	

Applications

Temperature Chamber, Food Machinery, Industrial Machinery, and etc.

Outline Dimensions

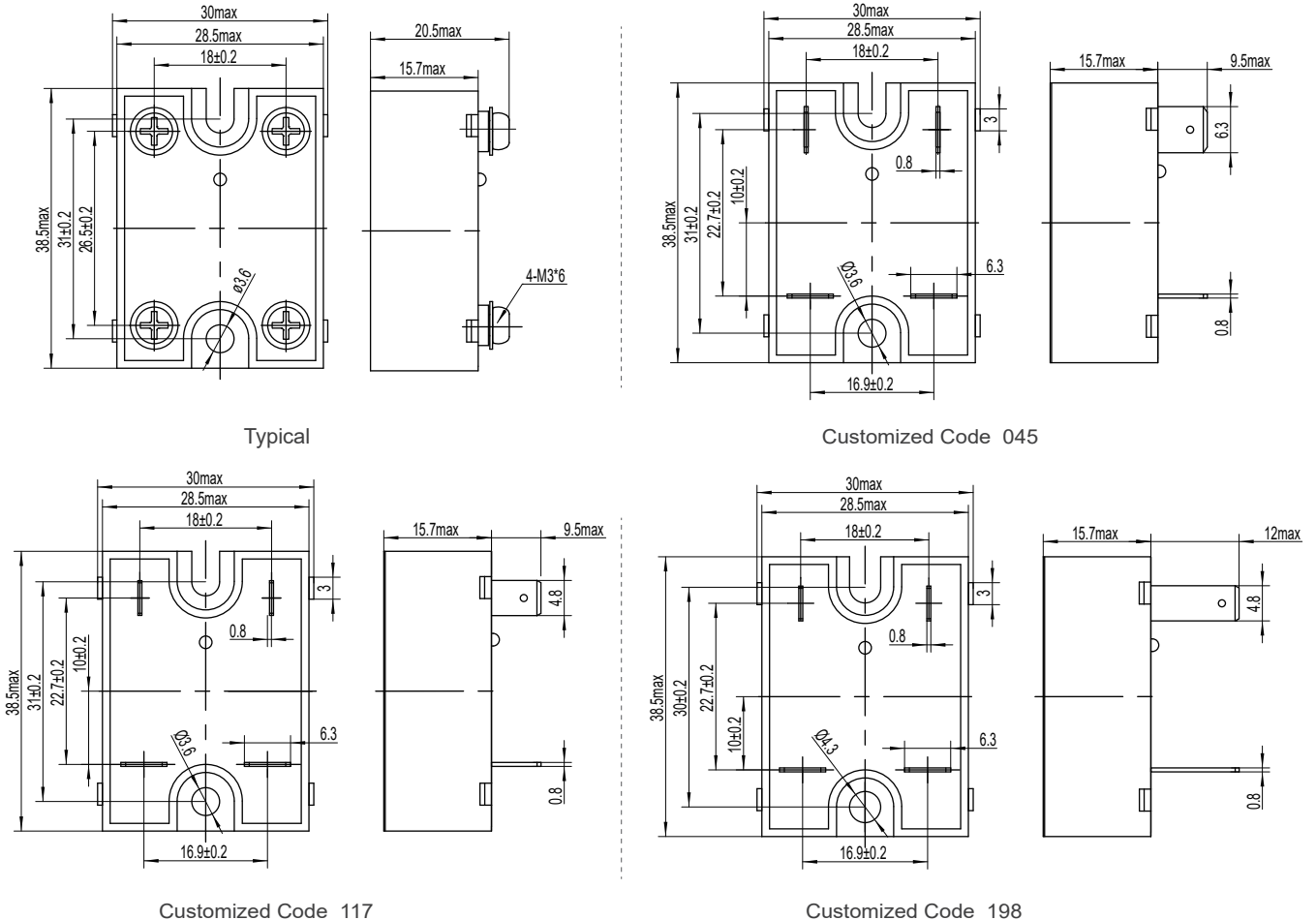

Outline Dimensions

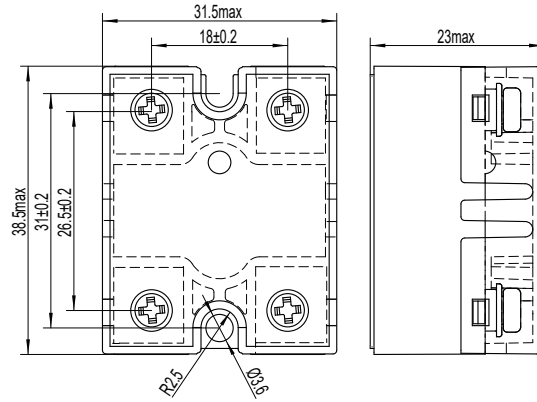

KSIM+KPC-2A

Wiring Diagram



Thermal Derating Curve

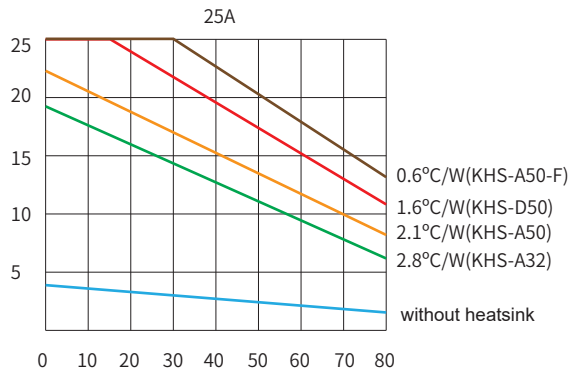
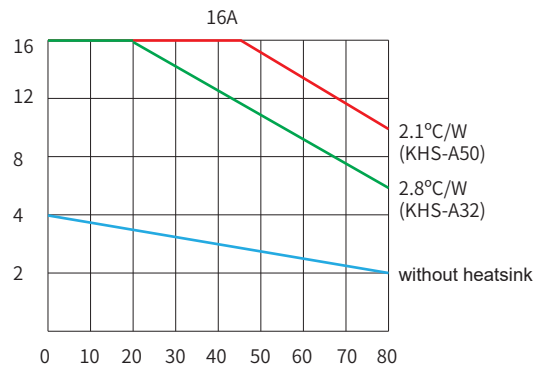
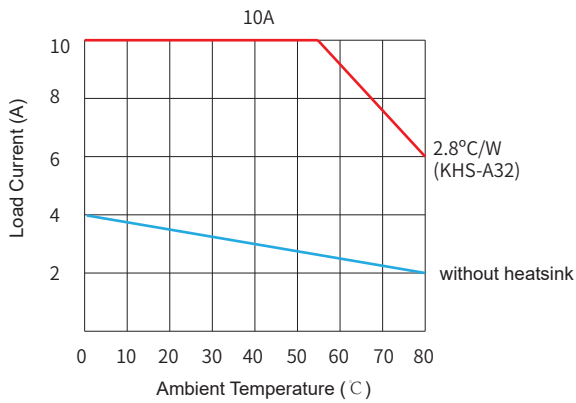

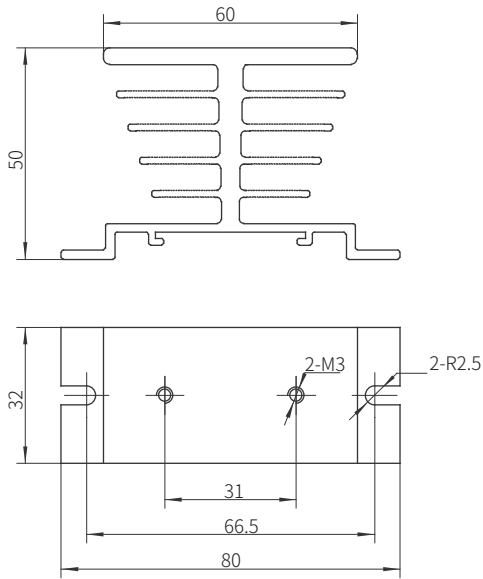

KHS-A32
(注: 建议安装孔尺寸为68mm)

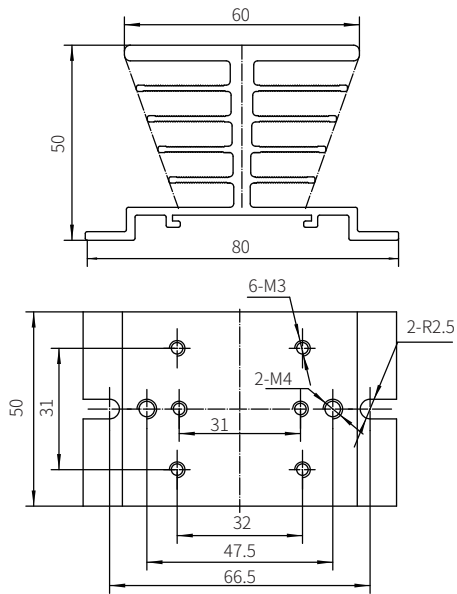

KHS-A50
(Note: The recommended mounting hole size is 68mm)

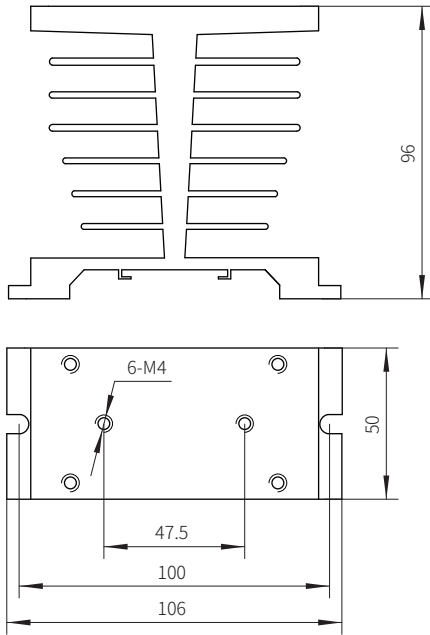

KHS-D50

General Notes

1. Relay must be mounted to proper sized heat sink based on thermal curves. Thermal grease or a thermal pad must be used between relay and heat sink and be torqued down to (13-15)/(1.5-1.7) in-lb/Nm.
2. When connection wiring to SSR, please ensure screws are torqued down properly. Recommended torque for input screw is (13-15)/(1.5-1.7) in-lb/Nm, output screw is (13-15)/(1.5-1.7) in-lb/Nm.
3. SSR's carrying load capacity is related to the operation ambient temperature and heat dissipation condition, please refer to the Thermal Derating Curve for derating.

Warnings

1. The product's side panels may be hot, allow the product to cool before touching.
2. Disconnect all power before installing or working with this equipment.
3. Verify all connections and replace all covers before turning on power.

Certification Standards

Certification	Test Standard
UL	UL508
	C22.2 No. 14-13
CCC	GB/T14048.5-2017
CQC	GB/T14048.5-2017
TUV	EN 60947-1:2007/A2:2014
	EN 60947-4-3:2014
CE	EN 60947-1:2007/A2:2014
	EN 60947-4-3:2014