

Product Description

- ◆ Zero-crossing Switching
- ◆ DC Input
- ◆ Load Current: 10A, 20A, 40A
- ◆ Internal RC/MOV Protection Circuit
- ◆ RoHS Compliant



Ordering Information

KMC	380	D	10	-24	(XXX)
KMC Series (1)	Load Voltage 380: 380VAC	Control Mode D: DC Control	Load Current 10: 10Amp 20: 20Amp 40: 40Amp	Control Voltage 12: 12VDC 24: 24VDC	Customized Code 130: Lead Terminal Blank:Screw Terminal

Note (1): The part number selection is subject to the following list.

Information	10A	20A	40A
380VAC	KMC380D10-12	KMC380D20-12	KMC380D40-12
	KMC380D10-24	KMC380D20-24	KMC380D40-24
	KMC380D10-12 (130)	KMC380D20-12 (130)	
	KMC380D10-24 (130)	KMC380D20-24 (130)	

General Specifications

Input Specifications (Ta=25°C)		
Control Voltage Range	12VDC	9.6-14.4VDC
	24VDC	19.2-28.8VDC
Must Turn-on Voltage	12VDC	9.6VDC
	24VDC	19.2VDC
Must Turn-off Voltage	12VDC	2VDC
	24VDC	2VDC
Maximum Input Current	12VDC	15mA@14.4VDC
	24VDC	25mA@28.8VDC

Output Specifications (Ta=25°C)		
Load Voltage Range	24 - 440VAC	
Maximum Turn-on Time	10ms	
Maximum Turn-off Time	10ms	
Maximum 1 Cycle Surge Current (50Hz)	10A	100A
	20A	200A
	40A	400A
Maximum Transient Overvoltage	1200Vpk	
Maximum Off-State Leakage Current@Rated Load Voltage	5mA	
Maximum On-State Voltage Drop@Rated Current	1.6Vrms	
Minimum Off-State dv/dt@Maximum Rated Voltage	200V/μs	

General Specifications

General Specifications (Ta=25°C)

Dielectric Strength (50/60Hz)	Input/Output	4000Vrms
	Input, output/Base	2500Vrms
Minimum Insulation Resistance (@500VDC)		1000MΩ
Ambient Temperature Range		-30°C ~ +80°C
Storage Temperature Range		-30°C ~ +100°C
Weight (Typical)	Screw Terminal	125g
	Lead Terminal	100g

Applications

Single phase motor control

Outline Dimensions

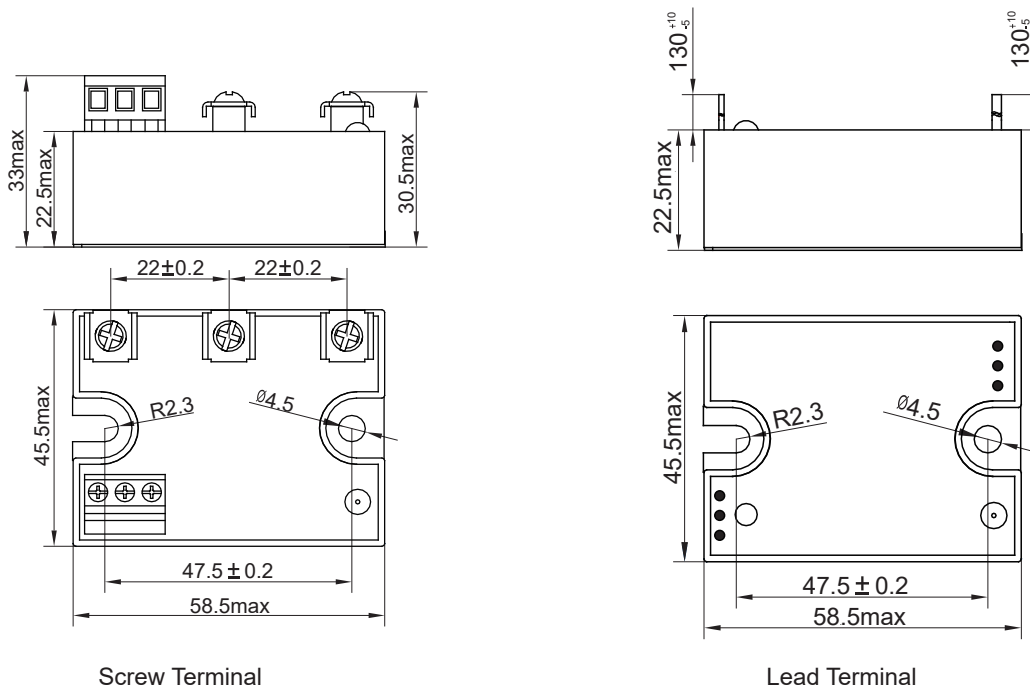

Wiring Diagram

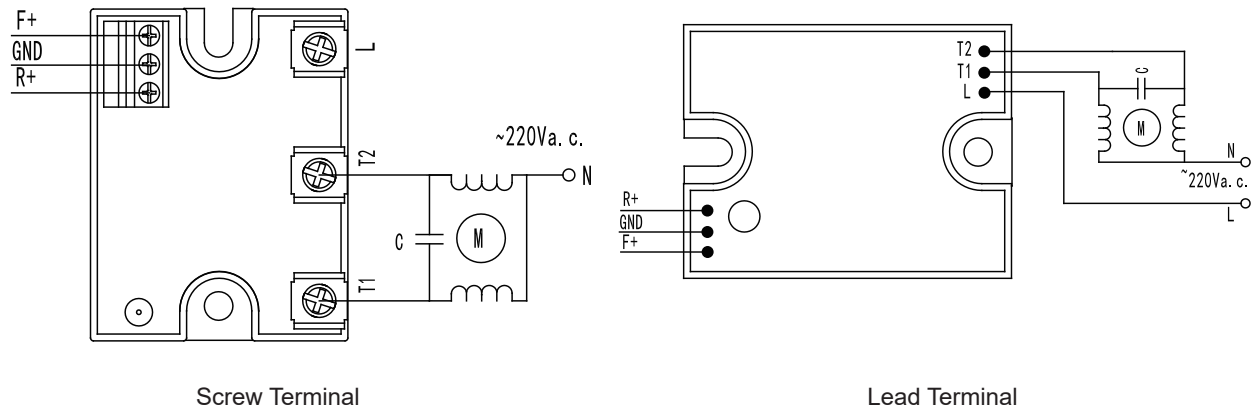

Thermal Derating Curve

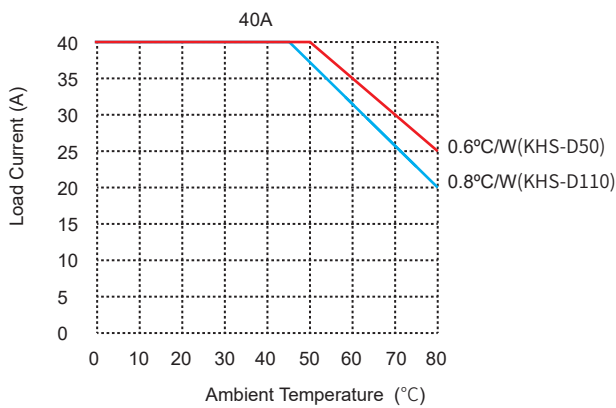
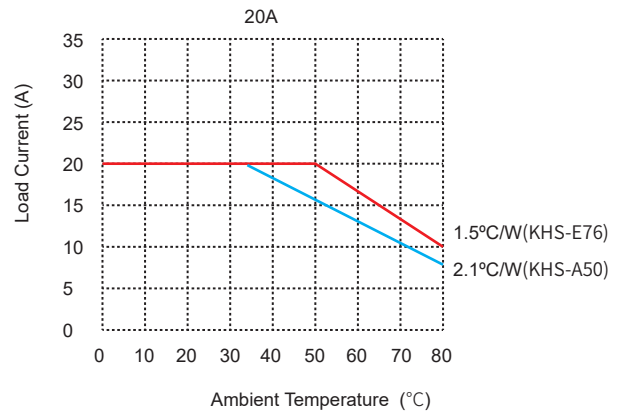
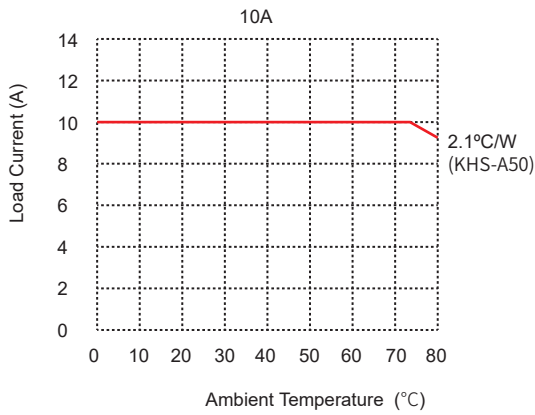

General Notes

1. Relay must be mounted to proper sized heat sink based on thermal curves. Thermal grease or a thermal pad must be used between relay .
2. When connecting wiring to SSR please ensure screws are torqued down properly: input 4.43/0.5 in-lb/N·m, output (0.98-1.37)N·m,8.67-12.12(lb-in)
3. When the operation temperature is high, please consider the derating as per the thermal curve.
- 4.Ensure the electrical grounding reliably during the use of the SSR.