

Product Description

- ◆ Zero crossing or Random-on switching
- ◆ TRIAC Output
- ◆ Control Voltage: 4-15VDC or 15-32VDC
- ◆ Load Current: 2A or 3A @24-440VAC
- ◆ Dielectric Strength: 4000Vrms
- ◆ Internal RC Absorption Circuit (Optional)
- ◆ PCB Mounted
- ◆ RoHS Compliant



Note: The product without RC or product with MOV is not UL certified.

Ordering Information

KSB	240	D	3	R	-L	N	T	M	(XXX)
KSB Series	Load Voltage 240: 240VAC 380: 380VAC	DC Control	Load Current 2: 2Amp 3: 3Amp	Switching Mode Blank: Zero Crossing R: Random-on	Control Voltage L: 4-15VDC Input H: 15-32VDC Input	Blank: with RC N: without RC	Blank: Standard T: T Type Footprint	Blank: without MOV M: with MOV	Customized Code

Note: Part numbers available are listed in the table below.

Control Voltage	2A		3A	
-L	KSB240D2-L(N)	KSB240D2R-L(N)	KSB240D3-L(N)	KSB240D3R-L(N)
	KSB240D2-L(N)T	KSB240D2R-L(N)T	KSB240D3-L(N)T	KSB240D3R-L(N)T
	KSB380D2-L(N)	KSB380D2R-L(N)	KSB380D3-L(N)	KSB380D3R-L(N)
	KSB380D2-L(N)T	KSB380D2R-L(N)T	KSB380D3-L(N)T	KSB380D3R-L(N)T
-H	KSB240D2-H(N)	KSB240D2R-H(N)	KSB240D3-H(N)	KSB240D3R-H(N)
	KSB240D2-H(N)T	KSB240D2R-H(N)T	KSB240D3-H(N)T	KSB240D3R-H(N)T
	KSB380D2-H(N)	KSB380D2R-H(N)	KSB380D3-H(N)	KSB380D3R-H(N)
	KSB380D2-H(N)T	KSB380D2R-H(N)T	KSB380D3-H(N)T	KSB380D3R-H(N)T
With MOV	KSB240D2-L(N)M	KSB240D2R-L(N)M	KSB240D3-L(N)M	KSB240D3R-L(N)M
	KSB380D2-L(N)M	KSB380D2R-L(N)M	KSB380D3-L(N)M	KSB380D3R-L(N)M
	KSB240D2-H(N)M	KSB240D2R-H(N)M	KSB240D3-H(N)M	KSB240D3R-H(N)M
	KSB380D2-H(N)M	KSB380D2R-H(N)M	KSB380D3-H(N)M	KSB380D3R-H(N)M
	KSB380D2-LTM			

General Specifications

Input Specifications (Ta=25°C)		
Control Voltage Range	L	4-15VDC
	H	15-32VDC
Must Turn-on Voltage	L	4VDC
	H	15VDC
Must Turn-off Voltage		1VDC
Maximum Input Current	L	40mA @15VDC
	H	25mA @32VDC

General Specifications

Output Specifications (Ta=25°C)		
Load Voltage Range	240VAC	24-280VAC
	380VAC	24-440VAC
Maximum Transient Overvoltage	240VAC	600Vpk
	380VAC	800Vpk
Maximum Off-State Leakage Current @Rated Load Voltage	without RC	0.1mA
	with RC	5mA
Minimum Off-State dv/dt@Maximum Rated Voltage	200V/μs	
Load Current Range	2A	0.1-2A
	3A	0.1-3A
Maximum Surge Current (50Hz)	2A	35Apk
	3A	80Apk
Maximum I ² t for Fusing (10ms)	2A	6.1A ² s
	3A	32A ² s
Maximum On-State Voltage Drop@Rated Current	1.5Vrms	
Maximum Turn-on Time	Zero Crossing : 1/2 cycle+1ms, Random-on: 1ms	
Maximum Turn-off Time	1/2cycle+1ms	
Operational Frequency Range	47-63Hz	
Minimum Power Factor (@ Maximum load)	0.5	
General Specifications (Ta=25°C)		
Dielectric Strength (50/60Hz)	4000Vrms	
Minimum Insulation Resistance (@500VDC)	1000MΩ	
Ambient Temperature Range	-30°C ~ +80 °C	
Storage Temperature Range	-30°C ~ +100 °C	
Weight (Typical)	15g	

Applications

Suitable for pumps, valve control, motor control, and ect.

Outline Dimensions

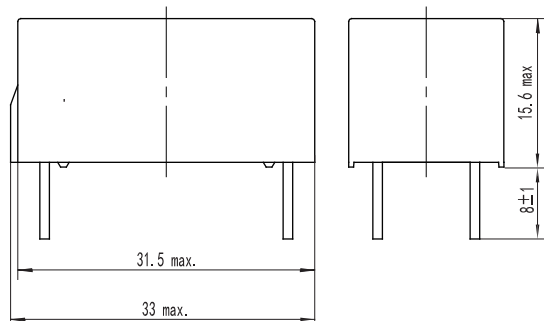
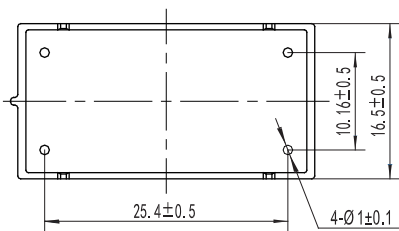

Standard Footprint

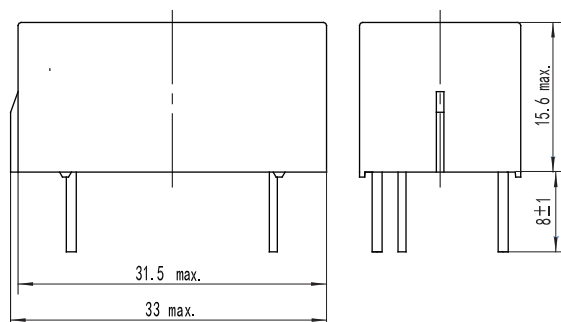
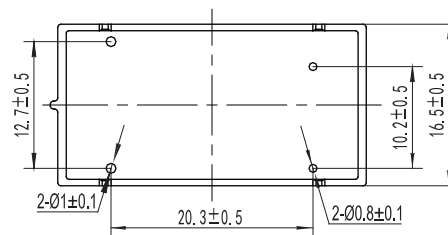

T Type Footprint

Wiring Diagram

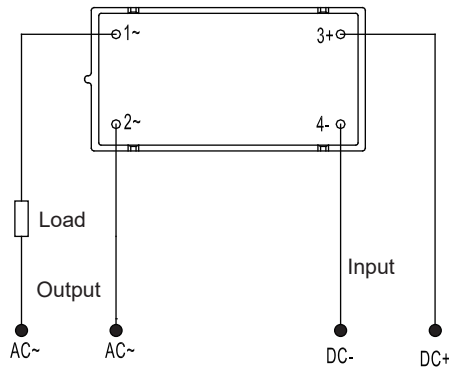

Standard Footprint

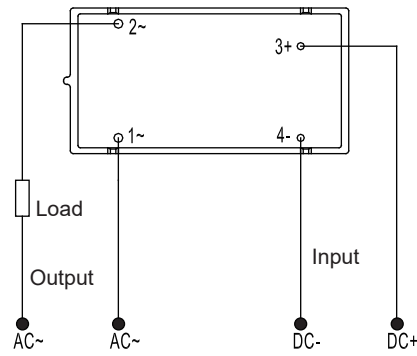

T Type Footprint

Thermal Derating Curve

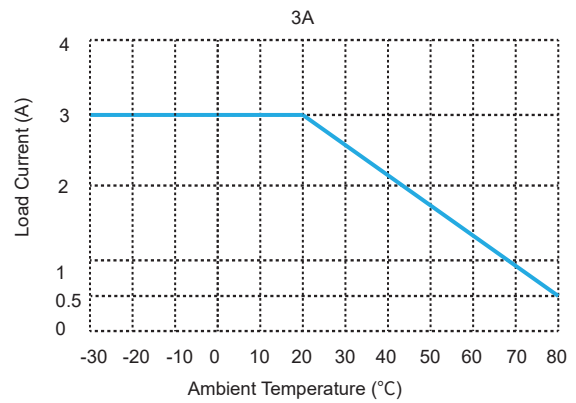
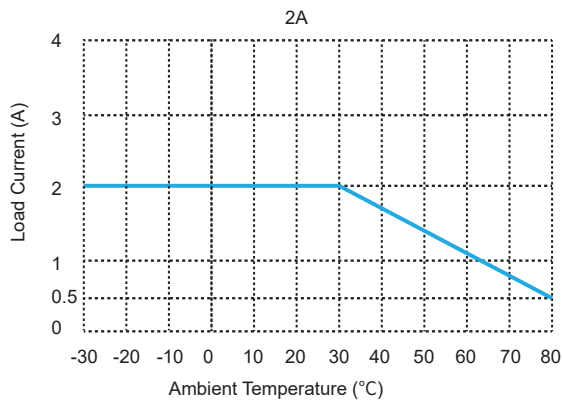

General Notes

1. Soldering must be finished within 10 seconds at 260°C, or finished within 5 seconds at 350°C. Otherwise it may cause damage to the relay.
2. Terminal polarity must be observed. Otherwise it may cause damage to the relay.
3. When ambient temperature is above 25°C, the maximum load current decreases. See thermal derating curve.

Certification Standards

Certification	Test standard
UL	UL508