



窗帘导轨铝型材

Aluminium Curtain Track Solution

2020

佛山市南海永丰铝型材有限公司
FOSHAN CITY NANHAI YONGFENG ALUMINIUM CO.,LTD.

中国广东省佛山市南海区海景路18号
ADD: No.18 Haijing Road, Nanhai District, Foshan City,
Guangdong, China

+86-757-85535511 85565511 85566711

+86-757-85520011 P.C: 528231

yfa@yfa.tm WWW.YFA.TM

窗帘导轨铝型材
Aluminium Curtain Track Solution



WWW.YFA.TM

▶ 关于永丰

About YONGFENG

永丰(YFA)创建于1995年,是全球铝合金窗帘导轨型材和铝合金外遮阳整体解决方案的供应商,植根于中国有色金属产业基地——佛山市南海区大沥镇。

以实干为本作为发展定位的一家民营企业,时至今日600+位伙伴依然坚守着创建之始的初心,在60000+平方米的现代化生产厂房一往无前,为客户、为行业、为社会创造更大价值。

历经25年的国内外市场的风雨洗礼,永丰人不断优化扩大产能,引入多种现代化的生产设备,12条专业窗帘导轨型材生产线配以5条不同性能的粉末喷涂生产线,年产量达到30000+吨。与此同时,分工明确、精准高效的各个深加工后工序,为铝合金外遮阳产品提供最有温度的解决方案。

迈入第25年,尽力做到更好依然是企业的核心价值!我们的团队将继续依附我们的品牌平台,怀着感恩的心携手前行,探索未来更多的未知!

Founded in 1995, Foshan City Nanhai YongFeng Aluminium Co., Ltd. (YFA) has developed into a comprehensive supplier of Aluminium Curtain Rail Profiles and Aluminium Sun Shade Solution. It is located in China Nonferrous Metal Production Base-Dali Town, Nanhai District of Foshan City.

As a private enterprise keeping 'incredible actions' as our development positioning, now YFA has more than 600 employees in a more than 60,000 square meters modern production workshop. We will create greater value for customers, industry, and for our society in this better and better YFA.

By experiencing ups and downs for 25 years, YFA continues to expand the production capacity and introduce advanced extrusion equipments. Nowadays, YFA has 12 professional extrusion lines and 5 powder coating lines with different properties, reaching an annual output of more than 30,000 tons. With clear division and high efficiency, each processing progress is the most temperature foundation of aluminium sunshade product solutions.

Keeping the value of the enterprise of Try My Best To Do and relying on brand platform, YFAers will continue to go forward to explore more unknowns in our 25-year-old!



2020

Try our best to do 尽力做到更好

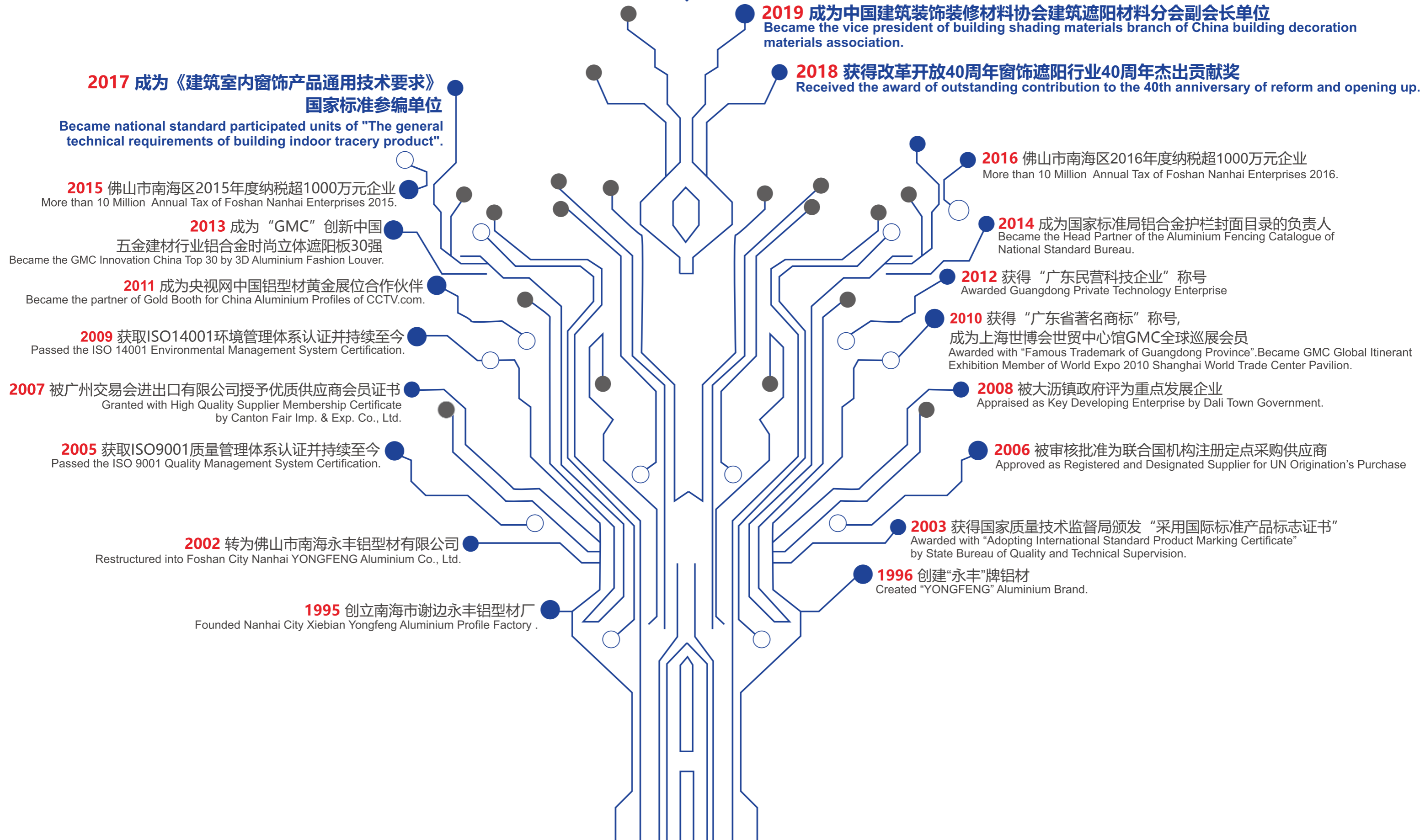

2019 成为中国建筑装饰装修材料协会建筑遮阳材料分会副会长单位
Became the vice president of building shading materials branch of China building decoration materials association.

2018 获得改革开放40周年窗饰遮阳行业40周年杰出贡献奖
Received the award of outstanding contribution to the 40th anniversary of reform and opening up.

2016 佛山市南海区2016年度纳税超1000万元企业
More than 10 Million Annual Tax of Foshan Nanhai Enterprises 2016.

2014 成为国家标准局铝合金护栏封面目录的负责人
Became the Head Partner of the Aluminium Fencing Catalogue of National Standard Bureau.

2012 获得“广东民营科技企业”称号
Awarded Guangdong Private Technology Enterprise

2010 获得“广东省著名商标”称号，
成为上海世博会世贸中心馆GMC全球巡展会员
Awarded with “Famous Trademark of Guangdong Province”. Became GMC Global Itinerant Exhibition Member of World Expo 2010 Shanghai World Trade Center Pavilion.

2008 被大沥镇政府评为重点发展企业
Appraised as Key Developing Enterprise by Dali Town Government.

2006 被审核批准为联合国机构注册定点采购供应商
Approved as Registered and Designated Supplier for UN Origination's Purchase

2003 获得国家质量技术监督局颁发“采用国际标准产品标志证书”
Awarded with “Adopting International Standard Product Marking Certificate” by State Bureau of Quality and Technical Supervision.

1996 创建“永丰”牌铝材
Created “YONGFENG” Aluminium Brand.

1995 创立南海市谢边永丰铝型材厂
Founded Nanhai City Xiebian Yongfeng Aluminium Profile Factory .

2017 成为《建筑室内窗饰产品通用技术要求》
国家标准参编单位

Became national standard participated units of "The general technical requirements of building indoor tracery product".

2015 佛山市南海区2015年度纳税超1000万元企业
More than 10 Million Annual Tax of Foshan Nanhai Enterprises 2015.

2013 成为“GMC”创新中国
五金建材行业铝合金时尚立体遮阳板30强
Became the GMC Innovation China Top 30 by 3D Aluminium Fashion Louver.

2011 成为央视网中国铝型材黄金展位合作伙伴
Became the partner of Gold Booth for China Aluminium Profiles of CCTV.com.

2009 获取ISO14001环境管理体系认证并持续至今
Passed the ISO 14001 Environmental Management System Certification.

2007 被广州交易会进出口有限公司授予优质供应商会员证书
Granted with High Quality Supplier Membership Certificate by Canton Fair Imp. & Exp. Co., Ltd.

2005 获取ISO9001质量管理体系认证并持续至今
Passed the ISO 9001 Quality Management System Certification.

2002 转为佛山市南海永丰铝型材有限公司
Restructured into Foshan City Nanhai YONGFENG Aluminium Co., Ltd.

12条专业窗帘型材挤压生产线 • 12 Extrusion Lines •

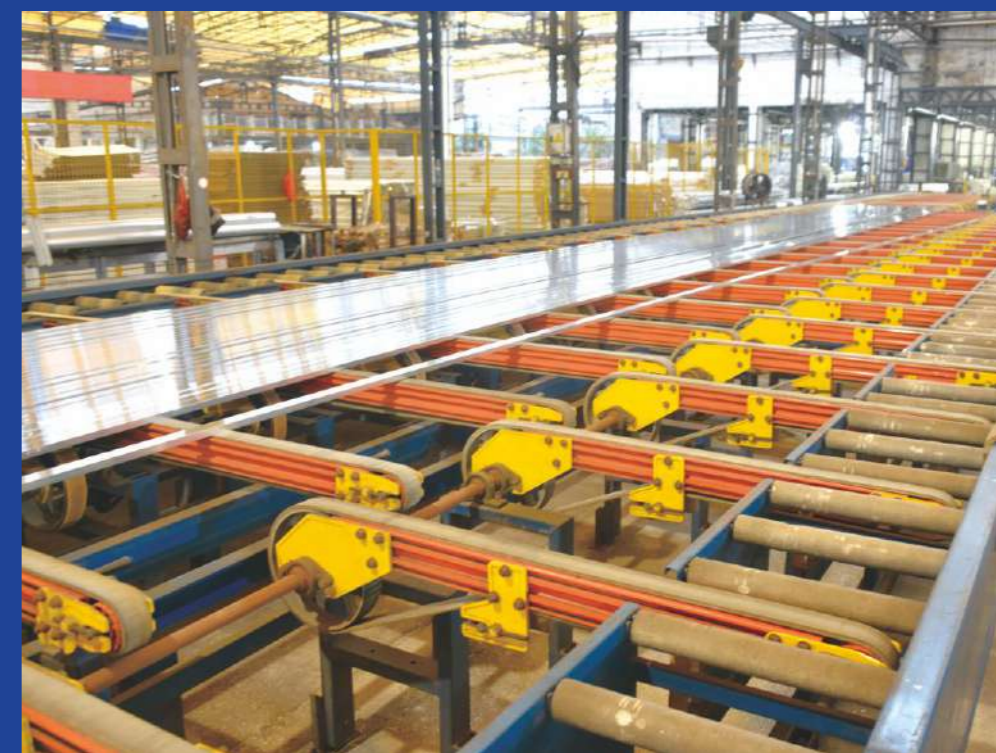

5条粉末喷涂生产线 5 Powder Coating Lines

于2019年9月正式投产的两条立式喷涂生产线
2 New Vertical Powder Coating Lines were put into production in September 2019

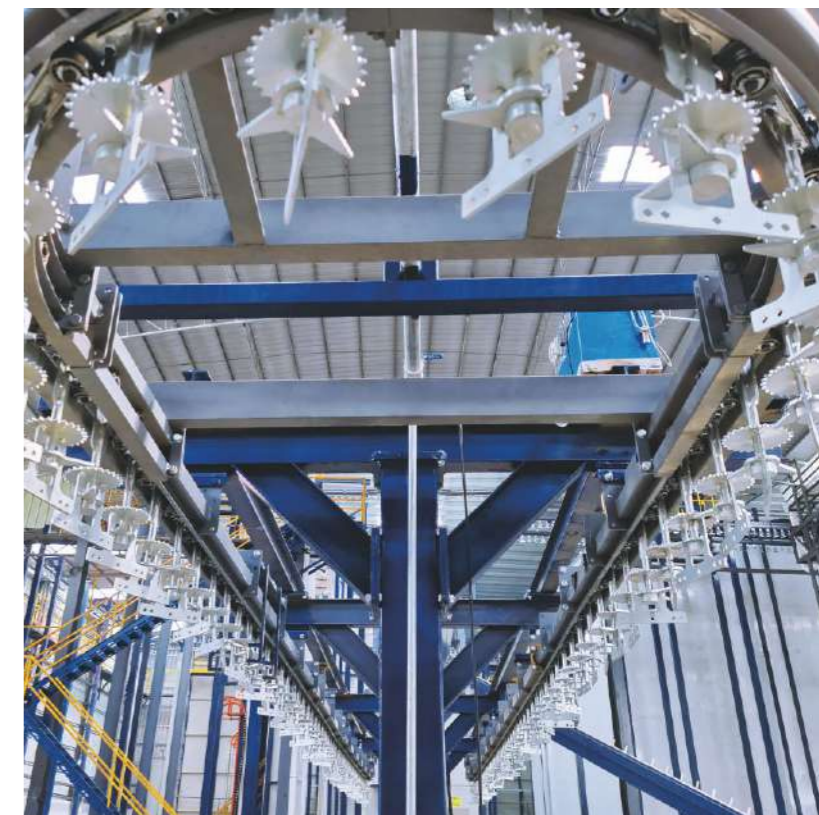

生产车间 YEA'S WORKSHOP



CONTENTS 目录

01 | 卷帘上杆
Roller Blinds Headrail (01-02)

02 | 卷帘管
Roller Tube (03-10)

03 | 卷帘下杆
Roller Blinds Bottom Rail (11-18)

04 | 斑马帘/柔纱帘&香格里拉帘系列
Zebra Blinds & Shangri-la Blinds System (19-26)

05 | 百叶百折帘&蜂巢帘系列
Venetian Blinds & Honeycomb Blinds System (27-34)

06 | 垂直帘&罗马帘&屏风帘系列
Vertical Blinds & Roman Blinds & Panel Track System (35-42)

07 | 铝芯系列
Tilt Rod (43-44)

08 | 轨道系列
Curtain Track (45-50)

09 | 户外遮阳系列
Sun Shade Blades (51-56)

10 | 扁条系列
Flat Bar (57-64)

11 | 圆管系列
Round Tube (65-78)

12 | 方管系列
Square Tube (79-89)

13 | 角铝系列
L Shape Profile (90-96)

14 | 槽型系列
U Channel Profile (97-103)

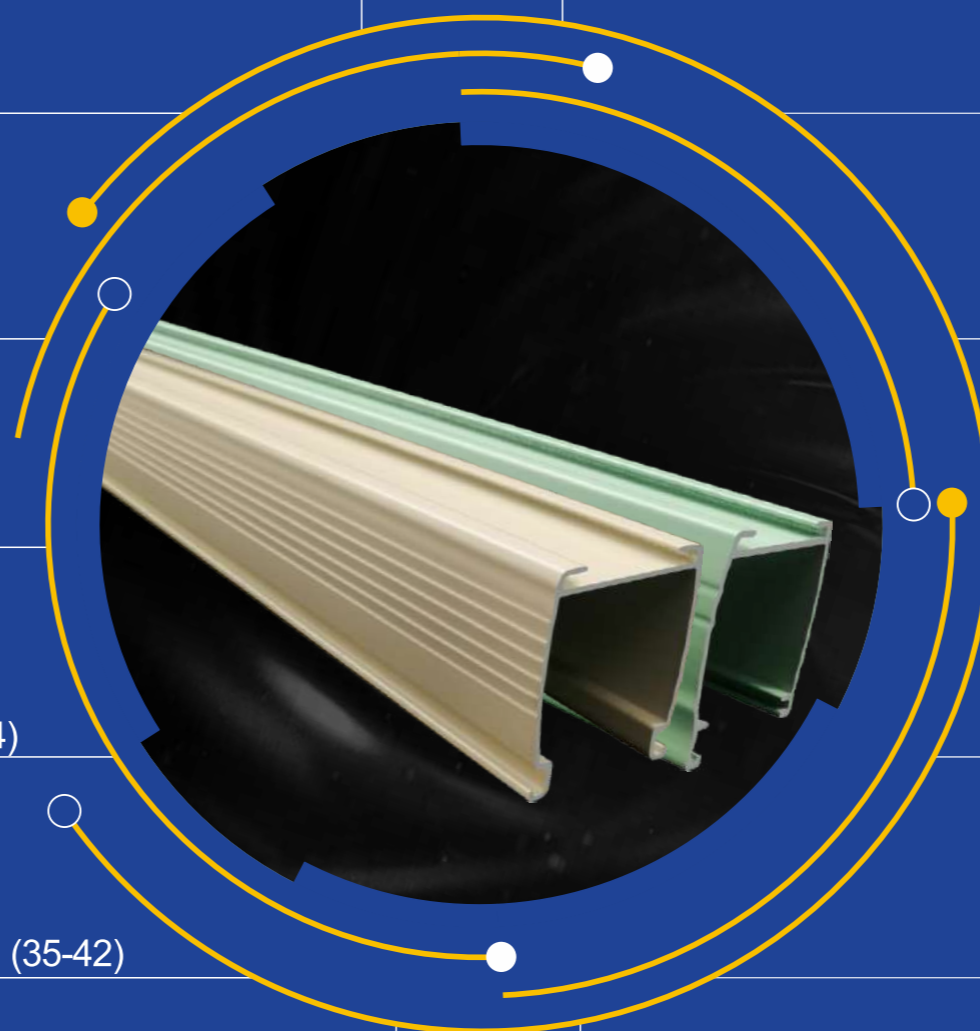

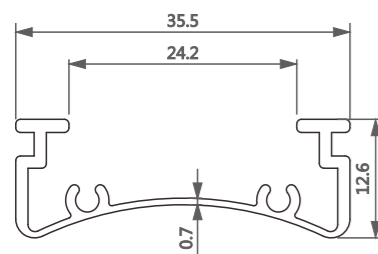

型号/Item No.-110127
米重/Weight-0.228kg/m

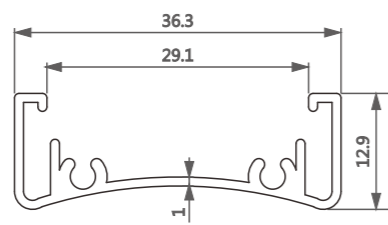

型号/Item No.-110181
米重/Weight-0.256kg/m

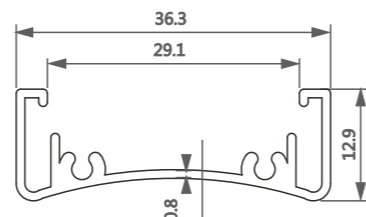

型号/Item No.-110163
米重/Weight-0.263kg/m

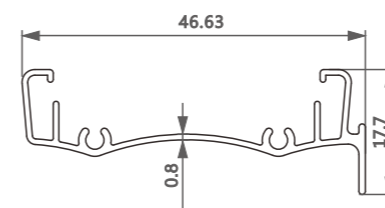

型号/Item No.-111344
米重/Weight-0.251 kg/m

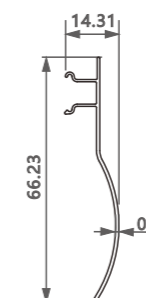

型号/Item No.-111345
米重/Weight-0.197kg/m

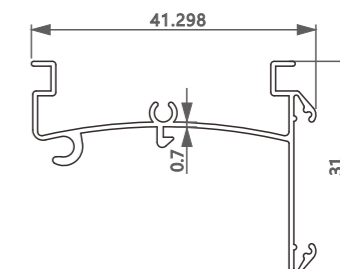

型号/Item No.-111368
米重/Weight-0.242kg/m

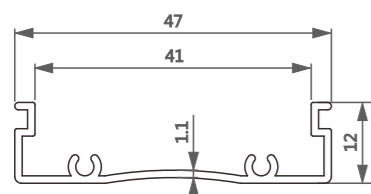

型号/Item No.-110113
米重/Weight-0.265kg/m

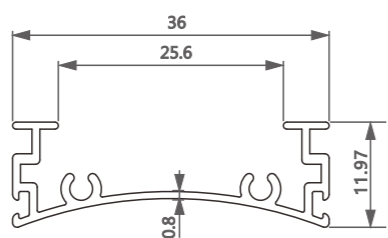

型号/Item No.-1116051
米重/Weight-0.217kg/m

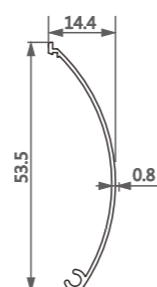

型号/Item No.-1116052
米重/Weight-0.150kg/m

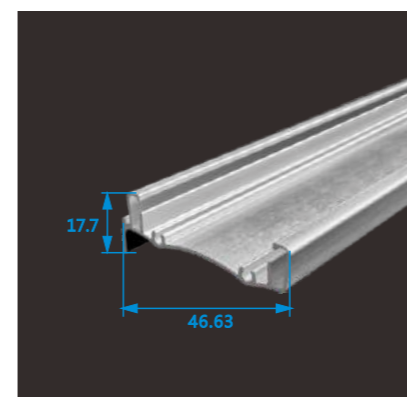

111344

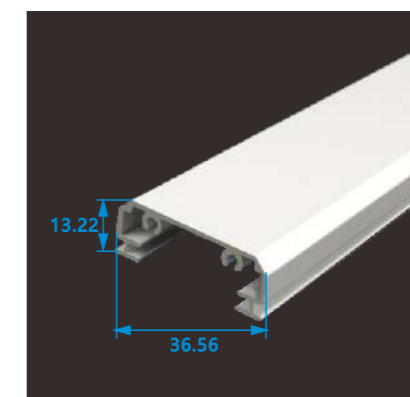

110128

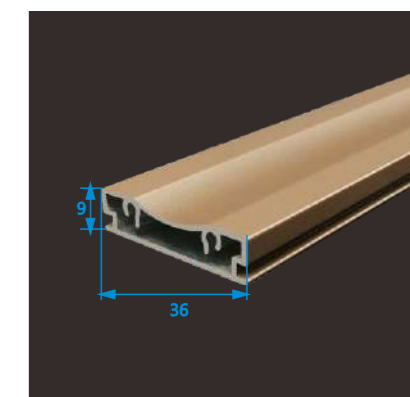

111301

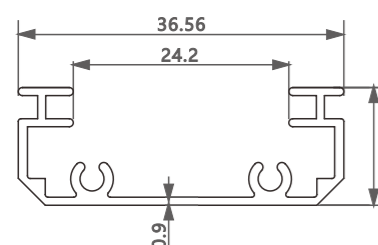

型号/Item No.-110128
米重/Weight-0.259kg/m

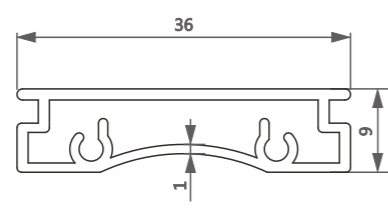

型号/Item No.-111301
米重/Weight-0.318kg/m

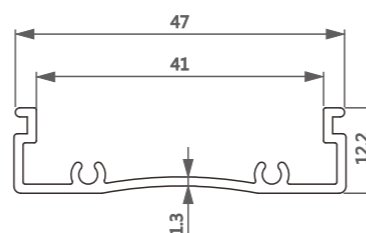

型号/Item No.-1118983
米重/Weight-0.31kg/m

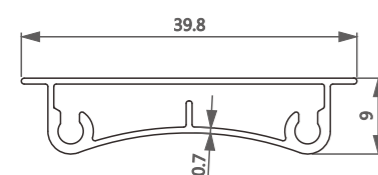

型号/Item No.-1116475
米重/Weight-0.218kg/m

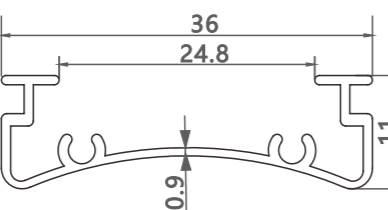

型号/Item No.-110165
米重/Weight-0.189kg/m

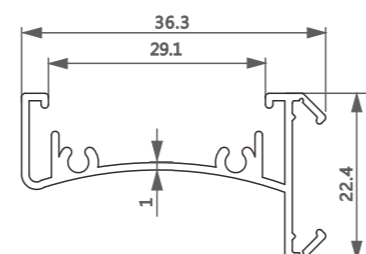

型号/Item No.-1116191
米重/Weight-0.316kg/m

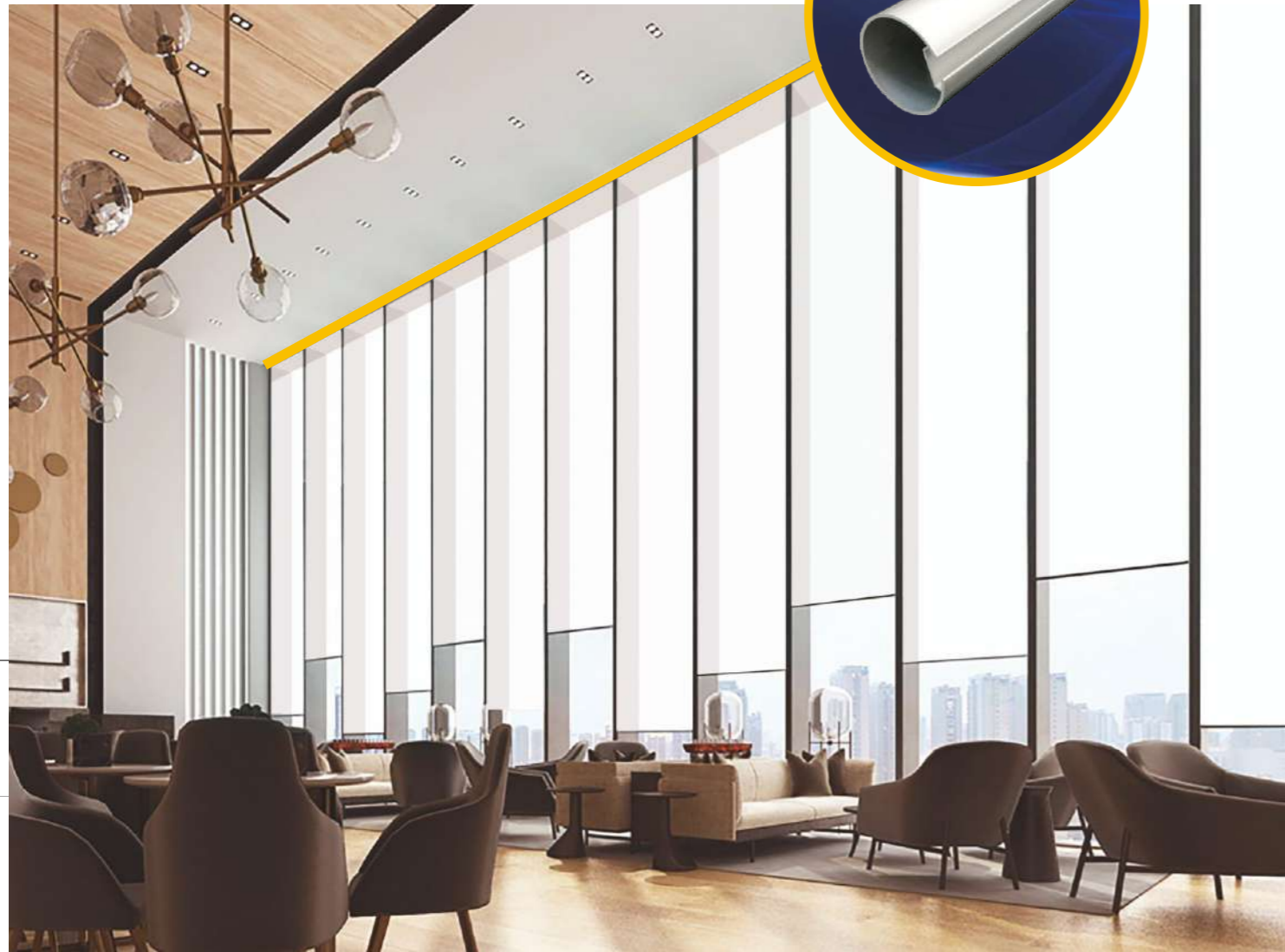

02 *Roller Tube*
 卷帘管



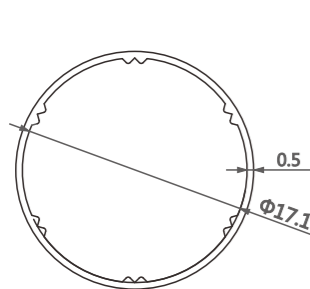

型号/Item No.-6110504
米重/Weight-0.082kg/m

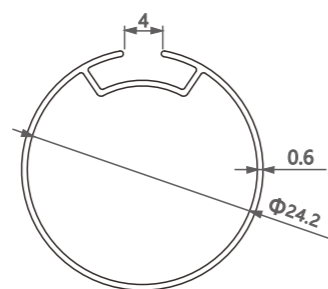

型号/Item No.-1118423
米重/Weight-0.146kg/m

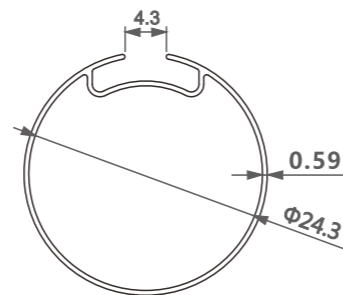

型号/Item No.-11161098
米重/Weight-0.144kg/m

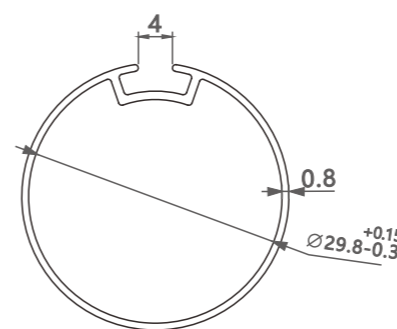

型号/Item No.-11161568
米重/Weight-0.239kg/m

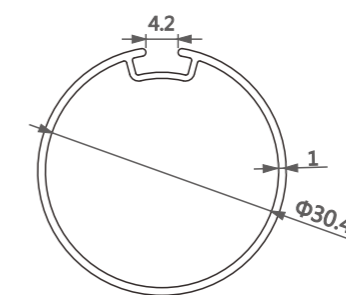

型号/Item No.-1116533
米重/Weight-0.284kg/m

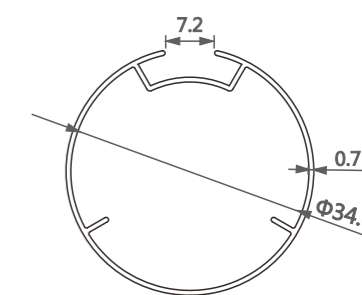

型号/Item No.-110110
米重/Weight-0.246kg/m

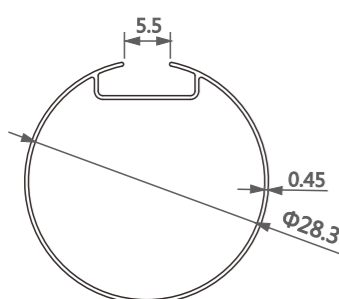

型号/Item No.-11181076-0.45
米重/Weight-0.125kg/m

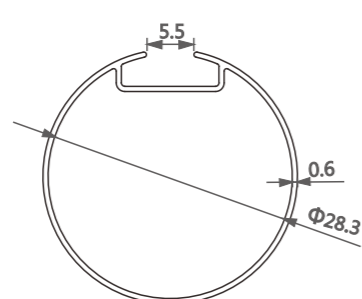

型号/Item No.-11181076-0.6
米重/Weight-0.167kg/m

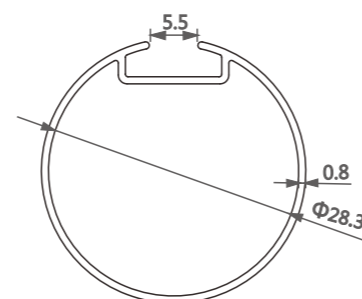

型号/Item No.-11181076-0.8
米重/Weight-0.224kg/m

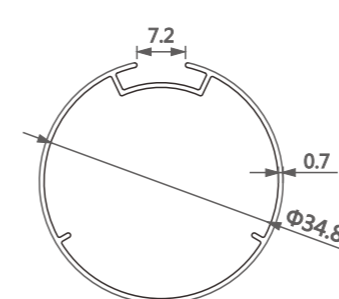

型号/Item No.-110179
米重/Weight-0.239kg/m

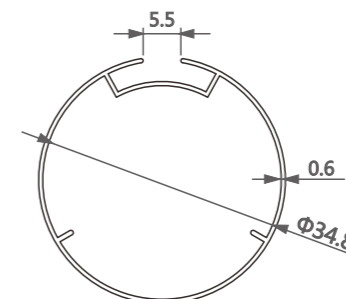

型号/Item No.-110166
米重/Weight-0.215kg/m

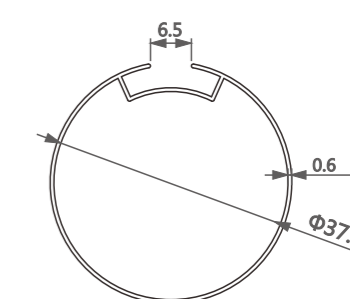

型号/Item No.-110123-0.6
米重/Weight-0.218kg/m

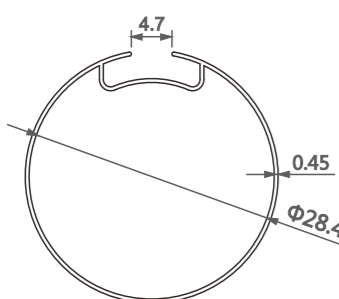

型号/Item No.-110131-0.45
米重/Weight-0.126kg/m

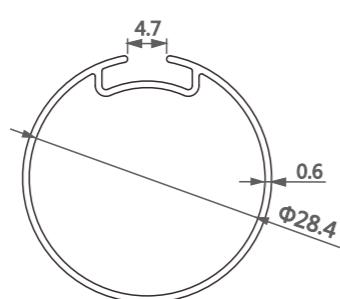

型号/Item No.-110131-0.6
米重/Weight-0.168kg/m

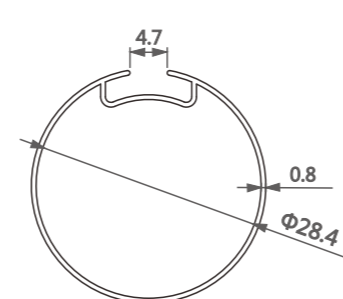

型号/Item No.-110131-0.8
米重/Weight-0.226kg/m

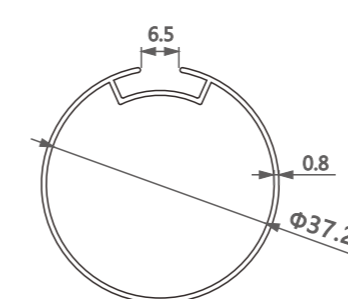

型号/Item No.-110123-0.8
米重/Weight-0.292kg/m

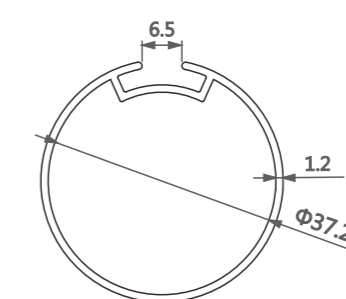

型号/Item No.-110123-1.2
米重/Weight-0.440kg/m

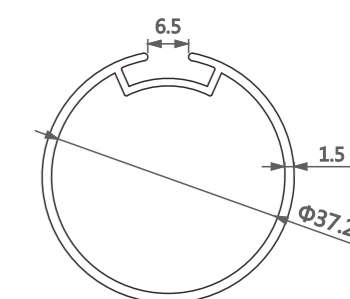

型号/Item No.-110123-1.5
米重/Weight-0.53kg/m

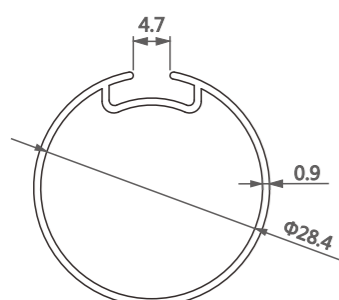

型号/Item No.-110131-0.9
米重/Weight-0.256kg/m

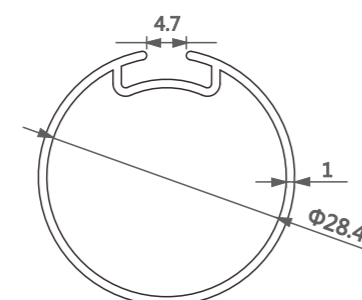

型号/Item No.-110131-1.0
米重/Weight-0.285kg/m

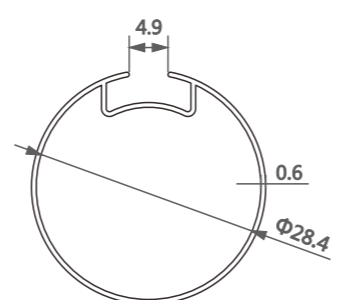

型号/Item No.-1101207
米重/Weight-0.171kg/m

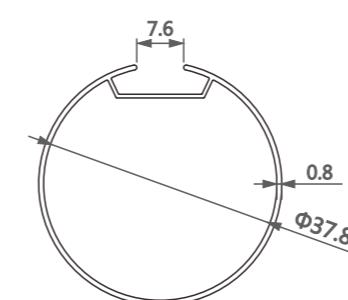

型号/Item No.-1116884-0.8
米重/Weight-0.28kg/m

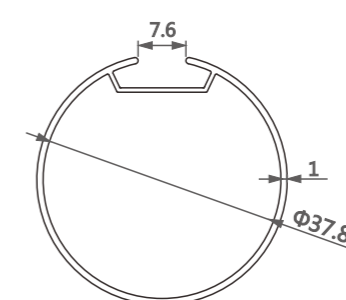

型号/Item No.-1116884-1.0
米重/Weight-0.35kg/m

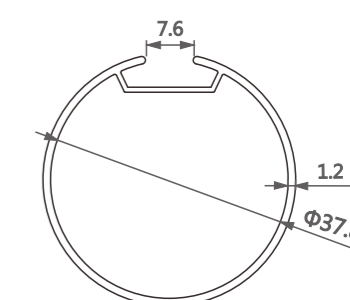

型号/Item No.-1116884-1.2
米重/Weight-0.419kg/m

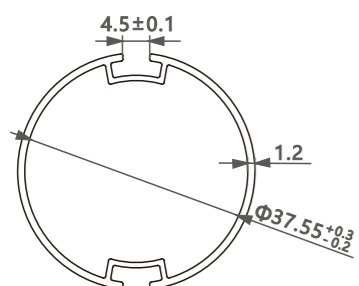

型号/Item No.-1118186
米重/Weight-0.441kg/m

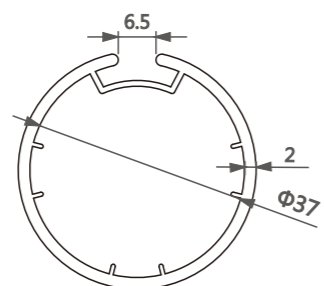

型号/Item No.-11181158
米重/Weight-0.703kg/m

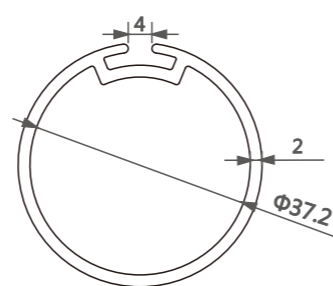

型号/Item No.-1118900
米重/Weight-0.734 kg/m

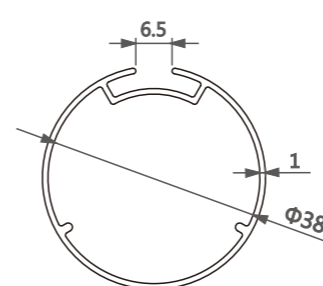

型号/Item No.-110102
米重/Weight-0.390kg/m

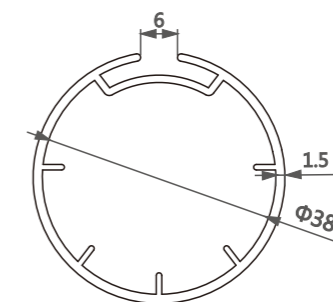

型号/Item No.-1116178
米重/Weight-0.588kg/m

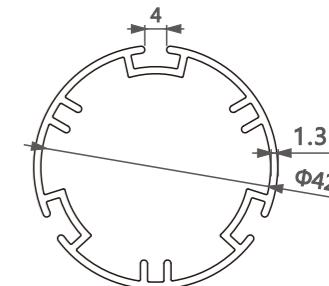

型号/Item No.-111379
米重/Weight-0.684kg/m

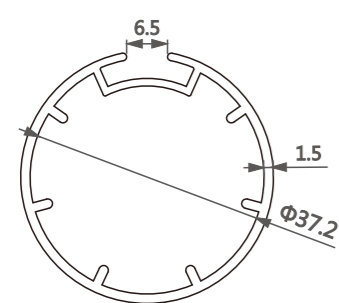

型号/Item No.-1101202
米重/Weight-0.6kg/m

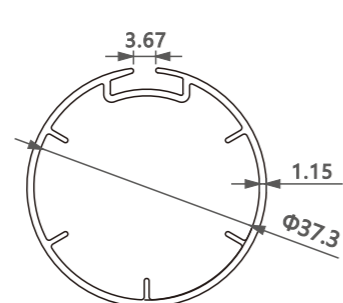

型号/Item No.-1118446
米重/Weight-0.457kg/m

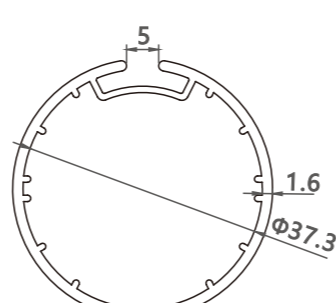

型号/Item No.-11181966
米重/Weight-0.597kg/m

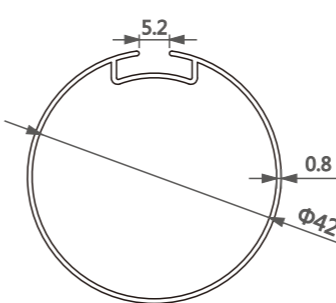

型号/Item No.-110104
米重/Weight-0.326kg/m

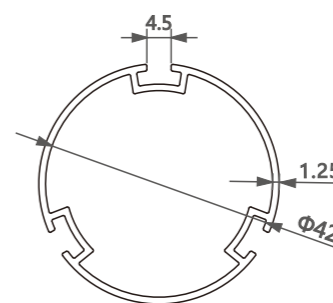

型号/Item No.-1118206
米重/Weight-0.564kg/m

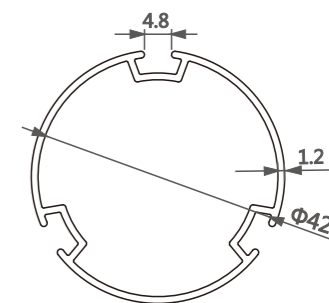

型号/Item No.-1116840
米重/Weight-0.54kg/m

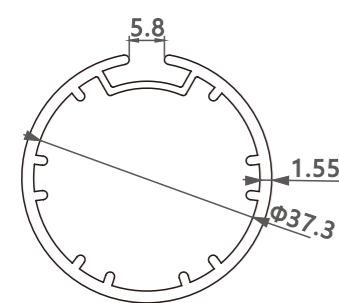

型号/Item No.-11181683
米重/Weight-0.751kg/m

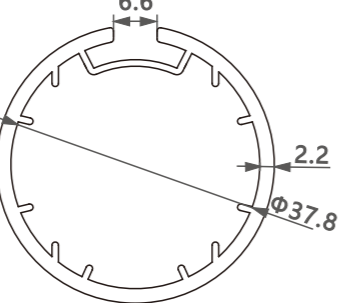

型号/Item No.-11181141
米重/Weight-0.83kg/m

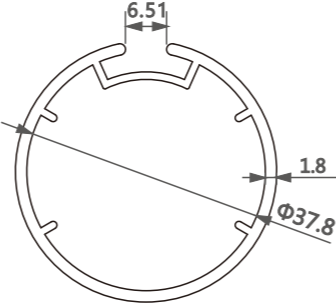

型号/Item No.-1101203
米重/Weight-0.676kg/m

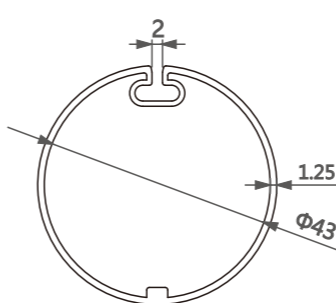

型号/Item No.-110139
米重/Weight-0.551kg/m

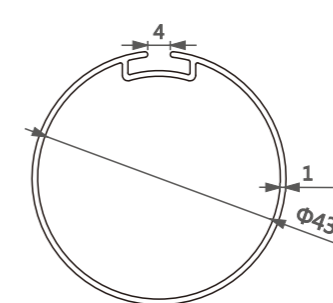

型号/Item No.-1116363
米重/Weight-0.414kg/m

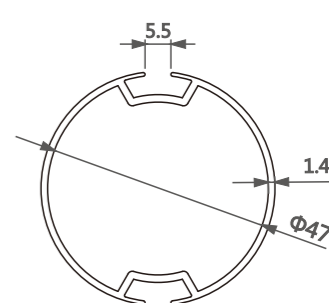

型号/Item No.-11181067
米重/Weight-0.683kg/m

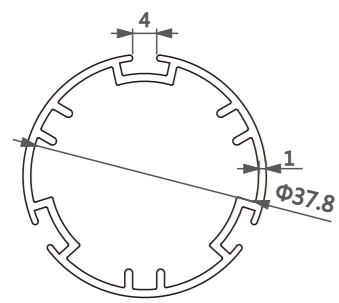

型号/Item No.-111380
米重/Weight-0.601kg/m

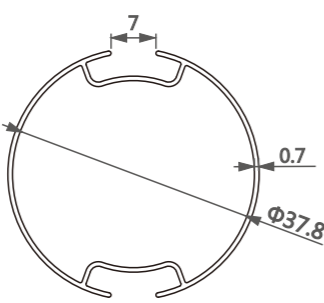

型号/Item No.-1116577
米重/Weight-0.279kg/m

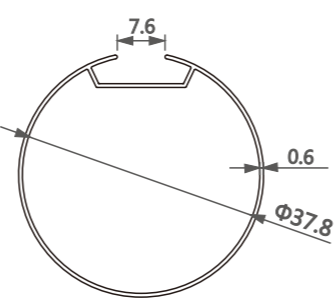

型号/Item No.-1116884-0.6
米重/Weight-0.21kg/m

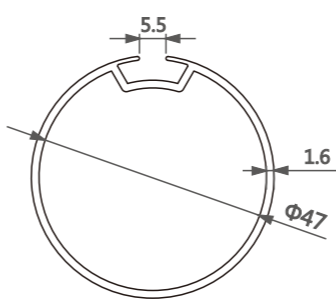

型号/Item No.-110192
米重/Weight-0.710kg/m

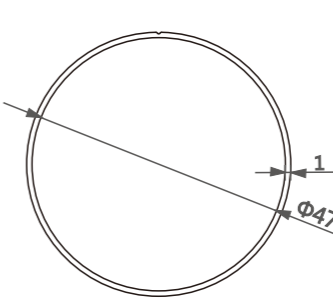

型号/Item No.-11161265-1.0
米重/Weight-0.411kg/m

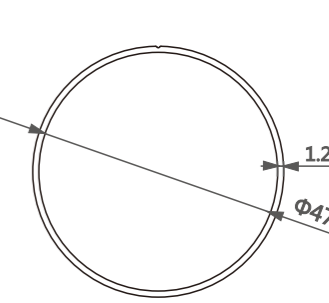

型号/Item No.-11161265-1.2
米重/Weight-0.496kg/m

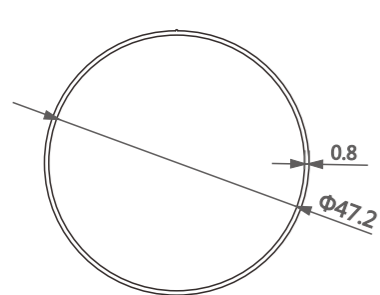

型号/Item No.-6110382-0.8
米重/Weight-0.330kg/m

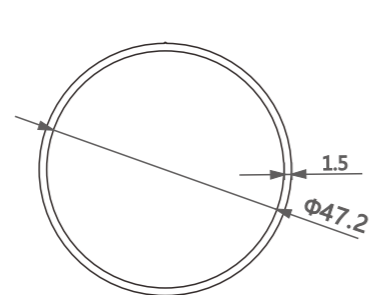

型号/Item No.-6110382
米重/Weight-0.627kg/m

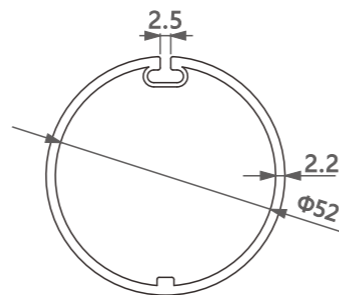

型号/Item No.-110140
米重/Weight-1.077kg/m

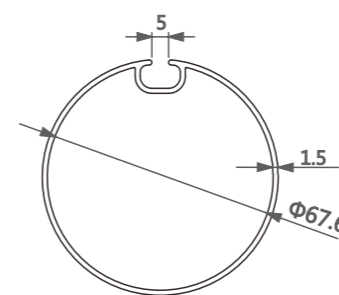

型号/Item No.-1118197
米重/Weight-0.970kg/m

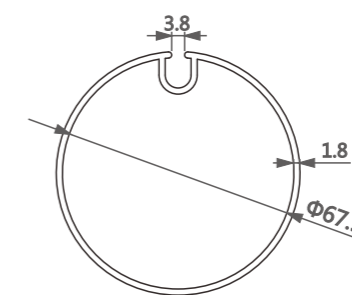

型号/Item No.-110124
米重/Weight-1.167kg/m

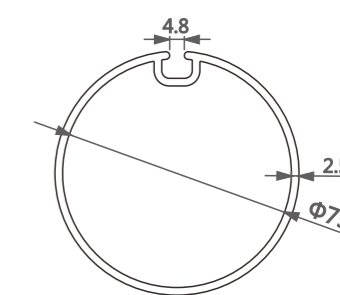

型号/Item No.-111396
米重/Weight-1.779kg/m

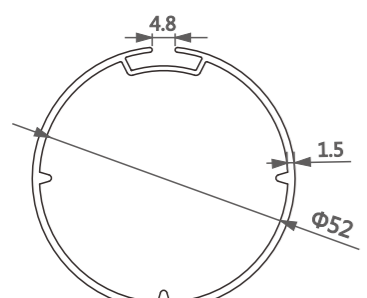

型号/Item No.-1118966
米重/Weight-0.743kg/m

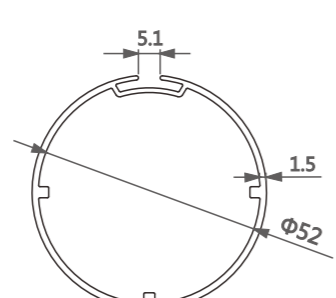

型号/Item No.-1116848
米重/Weight-0.758kg/m

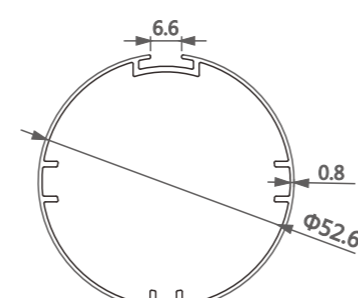

型号/Item No.-1116333-0.8
米重/Weight-0.472kg/m

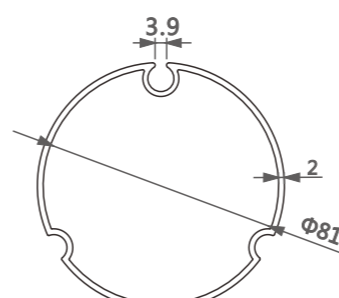

型号/Item No.-11161248
米重/Weight-1.554kg/m

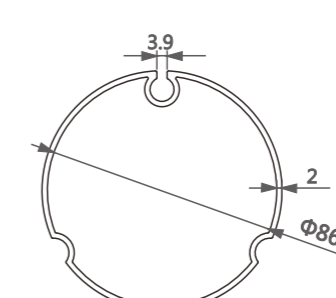

型号/Item No.-1116945
米重/Weight-1.658kg/m

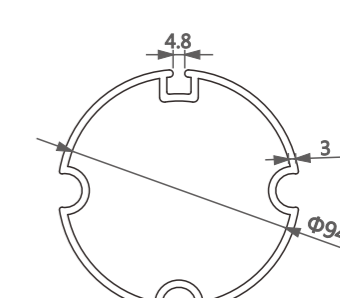

型号/Item No.-1116141
米重/Weight-2.965kg/m

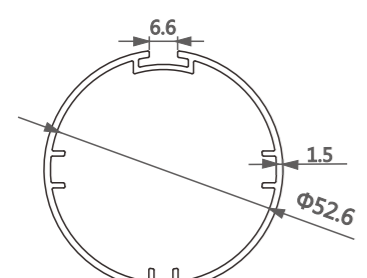

型号/Item No.-1116333-1.5
米重/Weight-0.789kg/m

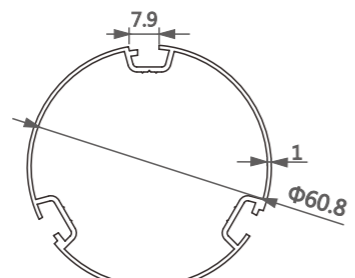

型号/Item No.-110121-1.0
米重/Weight-0.704kg/m

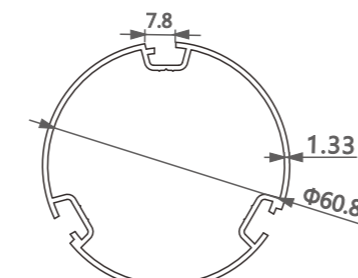

型号/Item No.-110121-1.33
米重/Weight-0.862kg/m

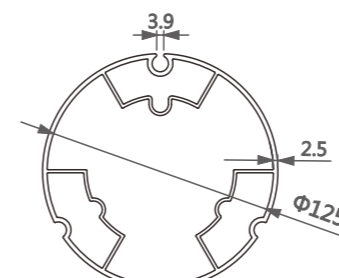

型号/Item No.-11181170
米重/Weight-4.205kg/m

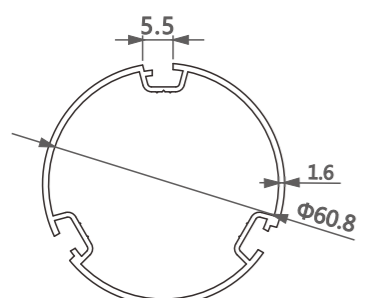

型号/Item No.-110121-1.6
米重/Weight-0.993kg/m

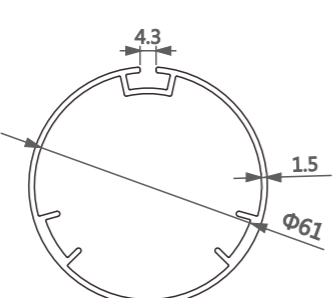

型号/Item No.-11161243
米重/Weight-1.059kg/m

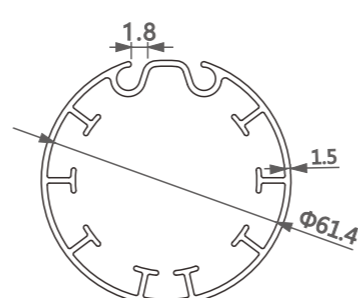

型号/Item No.-1118911
米重/Weight-1.270kg/m

03 *Roller Blind Bottom Rail*

卷帘下杆

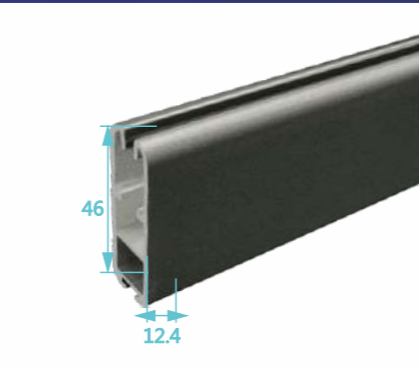

0900420



11161636



11161181



11161132

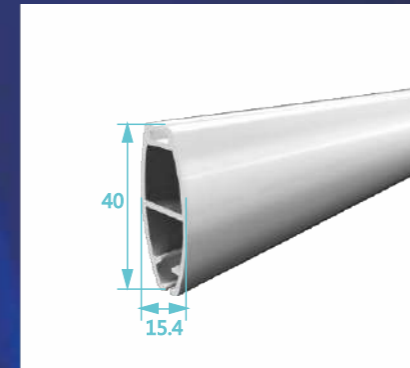

1116649



110115-0.8

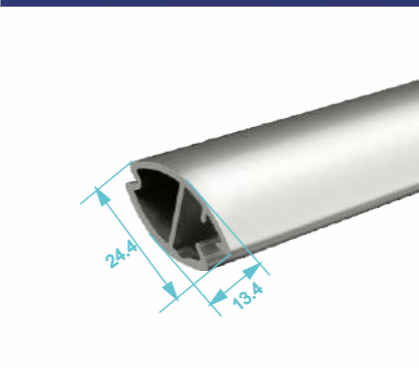

1118978

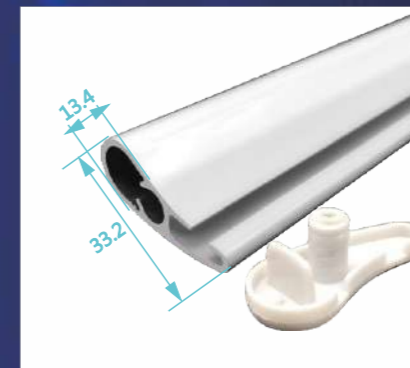

1118695



1116355

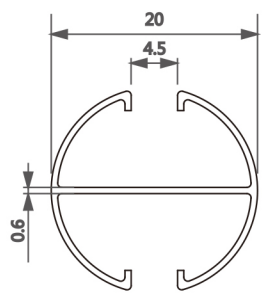

型号/Item No.-110115-0.6
米重/Weight-0.125kg/m

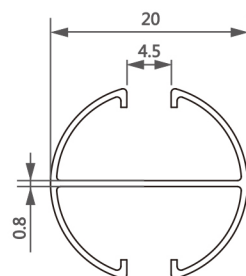

型号/Item No.-110115-0.8
米重/Weight-0.16 kg/m

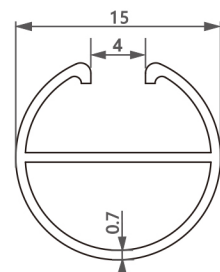

型号/Item No.-110116
米重/Weight-0.106kg/m

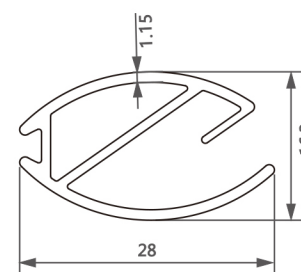

型号/Item No.-1118147
米重/Weight-0.267kg/m

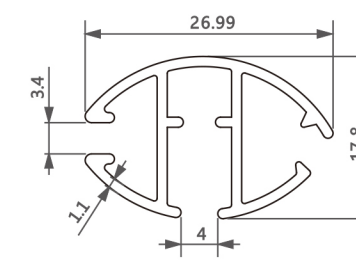

型号/Item No.-11161150
米重/Weight-0.28kg/m

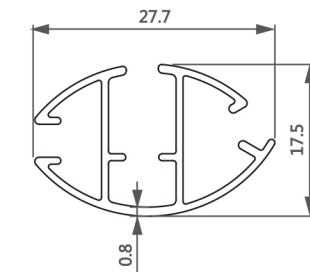

型号/Item No.-11181356
米重/Weight-0.224kg/m

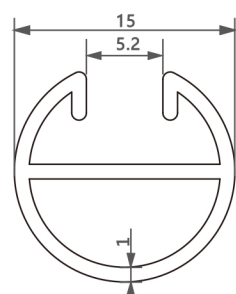

型号/Item No.-1116099
米重/Weight-0.152kg/m

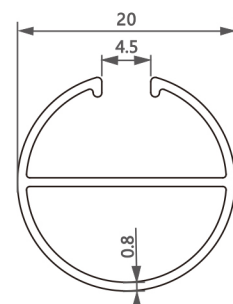

型号/Item No.-110117
米重/Weight-0.166kg/m

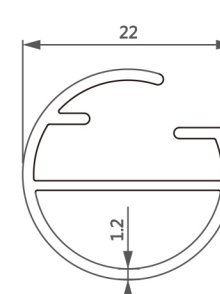

型号/Item No.-111359
米重/Weight-0.260kg/m

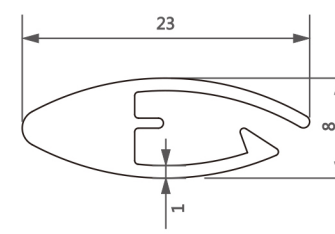

型号/Item No.-1116432
米重/Weight-0.216kg/m

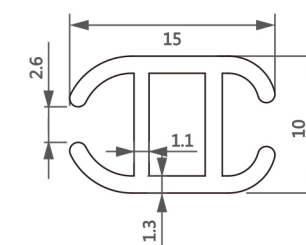

型号/Item No.-1907484
米重/Weight-0.162 kg/m

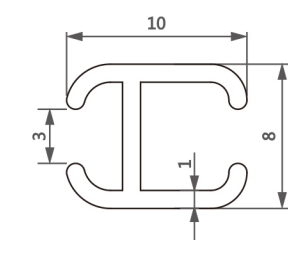

型号/Item No.-11181614
米重/Weight-0.078kg/m

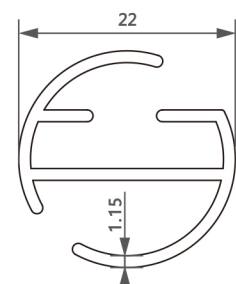

型号/Item No.-110185
米重/Weight-0.270kg/m

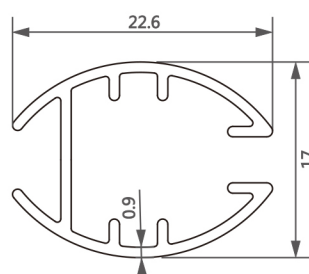

型号/Item No.-1116994
米重/Weight-0.192kg/m

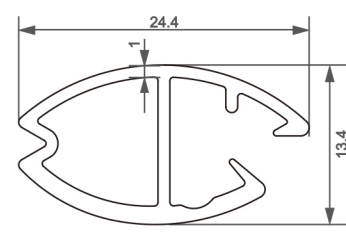

型号/Item No.-1118978
米重/Weight-0.217kg/m

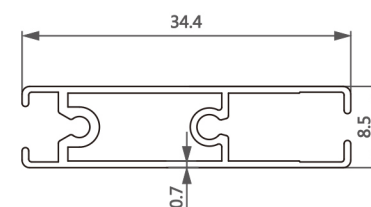

型号/Item No.-1907243-0.7
米重/Weight-0.199kg/m

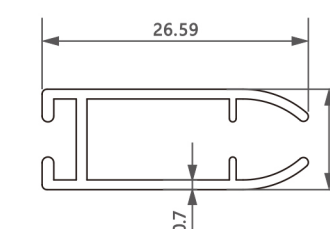

型号/Item No.-1907195-0.7
米重/Weight-0.146kg/m

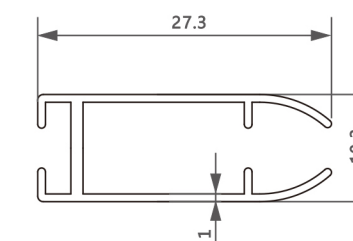

型号/Item No.-1907195-1.0
米重/Weight-0.199kg/m

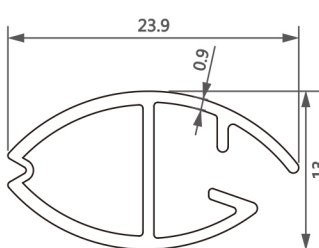

型号/Item No.-1116470
米重/Weight-0.180kg/m

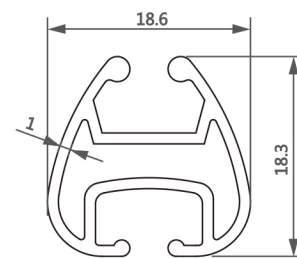

型号/Item No.-1118984
米重/Weight-0.247kg/m

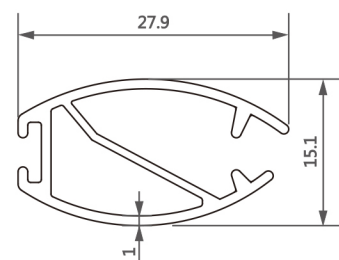

型号/Item No.-1116453
米重/Weight-0.249kg/m

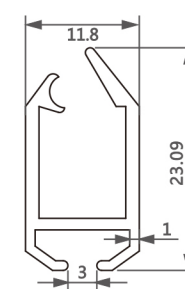

型号/Item No.-110120
米重/Weight-0.207kg/m

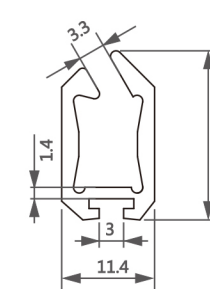

型号/Item No.-110119
米重/Weight-0.254kg/m

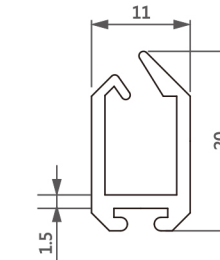

型号/Item No.-11161489
米重/Weight-0.211 kg/m

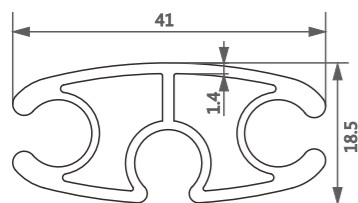

型号/Item No.-11161132
 米重/Weight-0.611kg/m

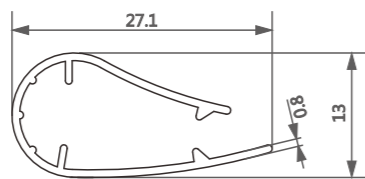

型号/Item No.-11181248
 米重/Weight-0.143kg/m

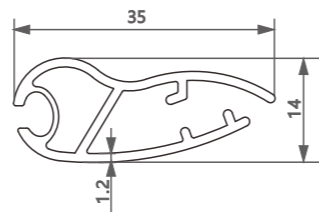

型号/Item No.-11161279
 米重/Weight-0.319kg/m

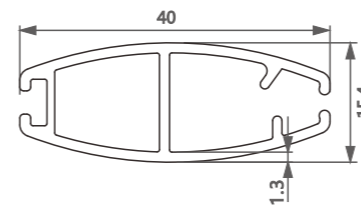

型号/Item No.-1116649
 米重/Weight-0.401kg/m

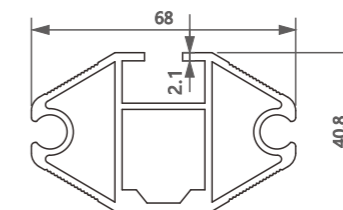

型号/Item No.-191011
 米重/Weight-1.566kg/m

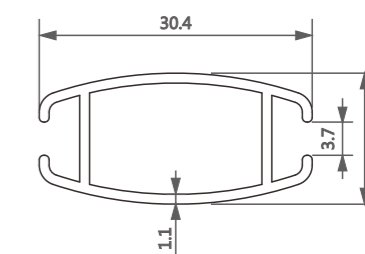

型号/Item No.-1116245
 米重/Weight-0.262kg/m

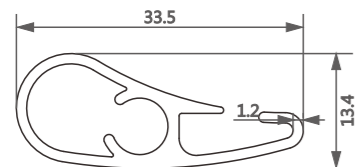

型号/Item No.-1116355
 米重/Weight-0.290kg/m

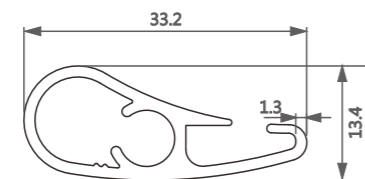

型号/Item No.-1118695
 米重/Weight-0.298kg/m

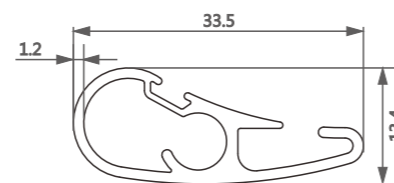

型号/Item No.-11161050
 米重/Weight-0.284kg/m

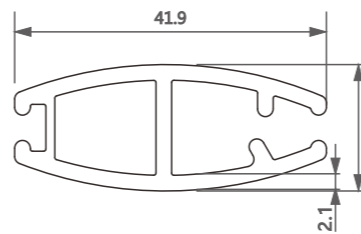

型号/Item No.-1116337
 米重/Weight-0.646kg/m

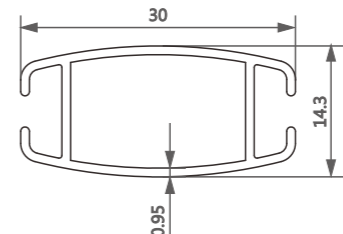

型号/Item No.-11161181
 米重/Weight-0.234kg/m

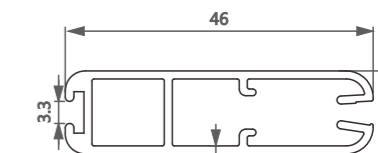

型号/Item No.-0900420
 米重/Weight-0.455kg/m

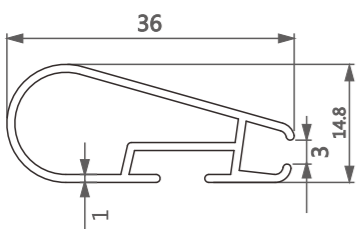

型号/Item No.-11181615
 米重/Weight-0.271kg/m

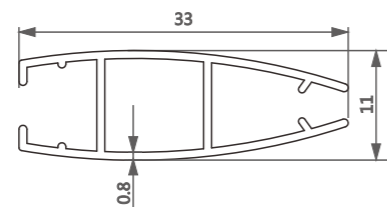

型号/Item No.-11161636
 米重/Weight-0.199kg/m

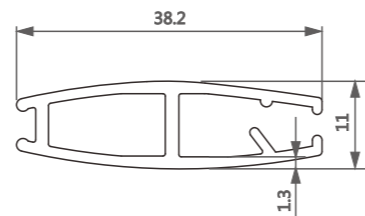

型号/Item No.-11181651
 米重/Weight-0.365kg/m

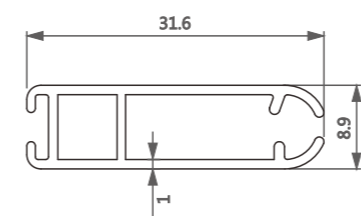

型号/Item No.-11161608
 米重/Weight-0.231kg/m

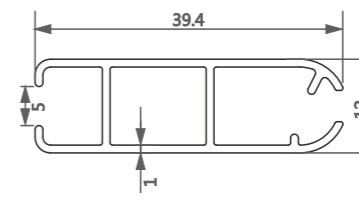

型号/Item No.-0901253
 米重/Weight-0.297kg/m

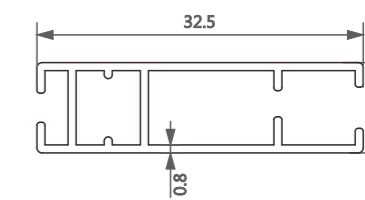

型号/Item No.-11181057
 米重/Weight-0.204kg/m

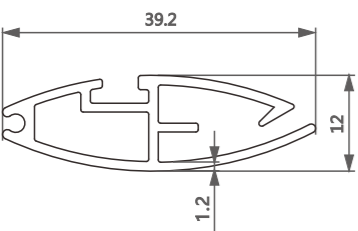

型号/Item No.-1116433
 米重/Weight-0.331kg/m

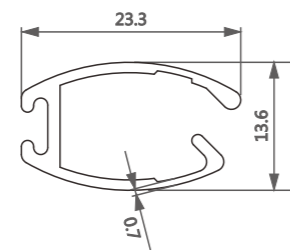

型号/Item No.-191071
 米重/Weight-0.190kg/m

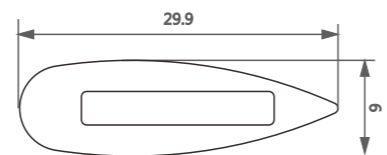

型号/Item No.-1116965
 米重/Weight-0.399kg/m

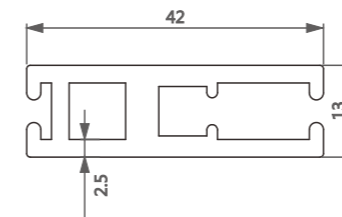

型号/Item No.-190713
 米重/Weight-0.807kg/m

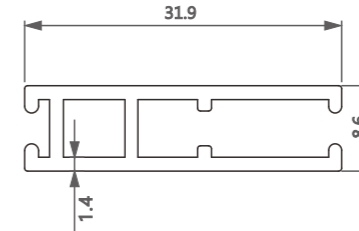

型号/Item No.-190718
 米重/Weight-0.311kg/m

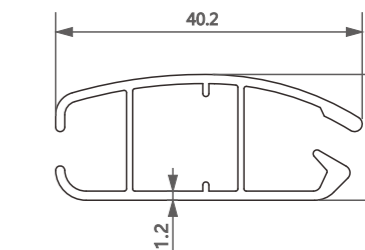

型号/Item No.-1118637
 米重/Weight-0.382kg/m

03 卷帘下杆 Roller Blinds Bottom Rail

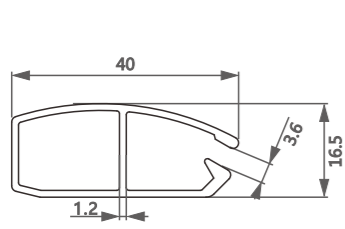

型号/Item No.-110172
米重/Weight-0.382kg/m

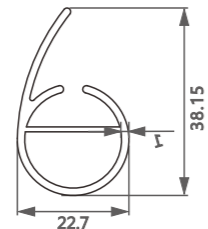

型号/Item No.-111827
米重/Weight-0.408kg/m

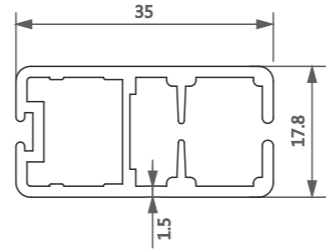

型号/Item No.-4278291
米重/Weight-0.53kg/m

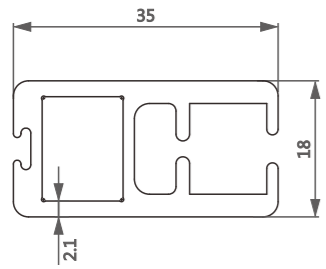

型号/Item No.-7908611
米重/Weight-0.742kg/m

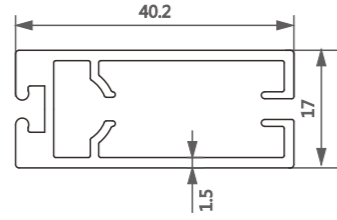

型号/Item No.-0900607
米重/Weight-0.582kg/m

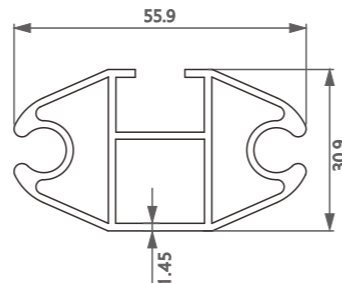

型号/Item No.-0900571
米重/Weight-0.961kg/m



可为客户提供配件的配套销售服务。
Components as Additional Service.

04 Zebra Blind System & Shangri-la Blind System

斑马帘/柔纱帘系列&香格里拉帘系列

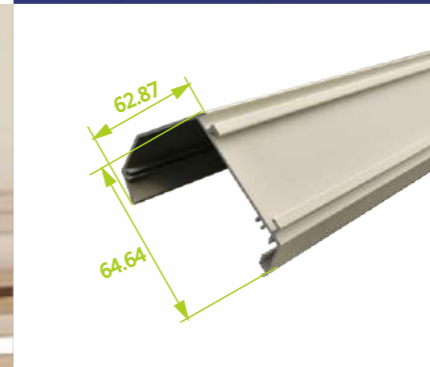

11181442



11182098



11181739



11182094

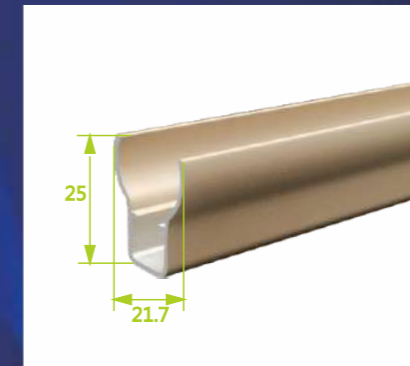

11181561

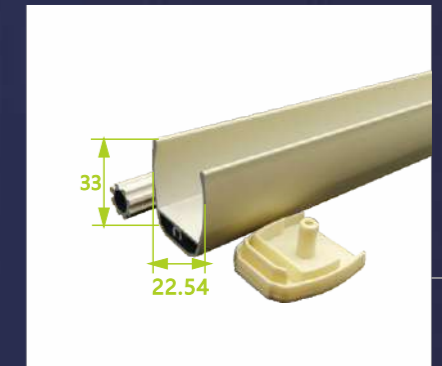

11161348



11181443



11161363



11161362

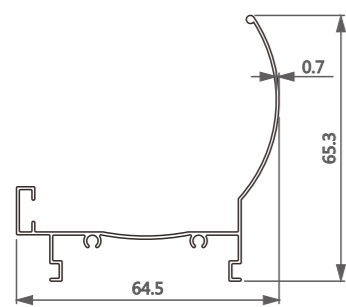

型号/Item No.-11161039
米重/Weight-0.359kg/m

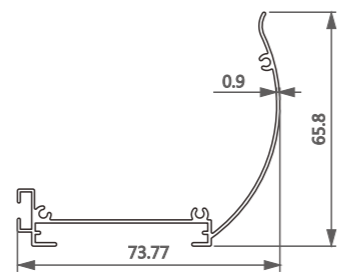

型号/Item No.-11161602
米重/Weight-0.484kg/m

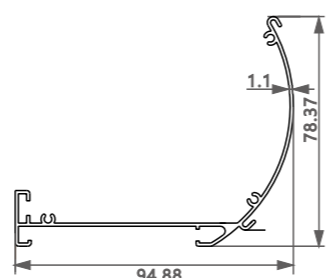

型号/Item No.-1116409
米重/Weight-0.712kg/m

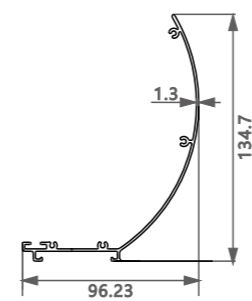

型号/Item No.-11181857
米重/Weight-0.982kg/m

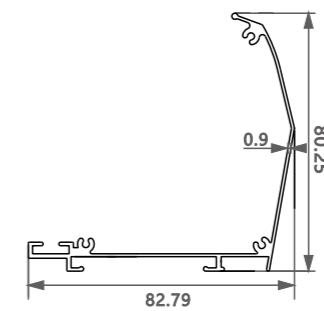

型号/Item No.-11181185
米重/Weight-0.684kg/m

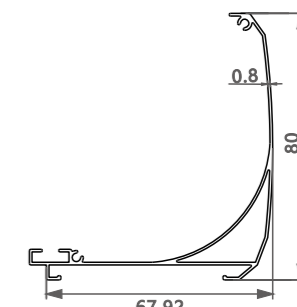

型号/Item No.-11182094
米重/Weight-0.535kg/m

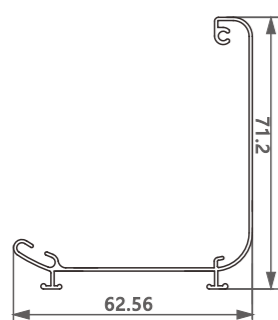

型号/Item No.-11181739
米重/Weight-0.426kg/m

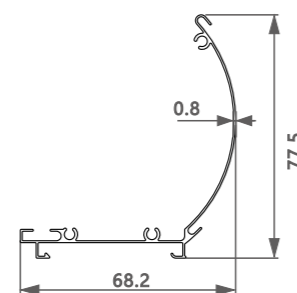

型号/Item No.-11161027
米重/Weight-0.468kg/m

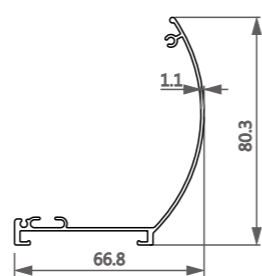

型号/Item No.-1116864
米重/Weight-0.558kg/m

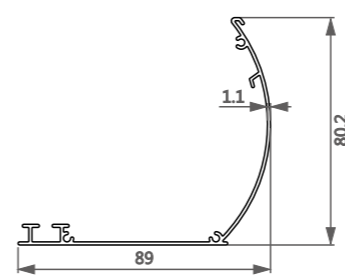

型号/Item No.-1116735
米重/Weight-0.623kg/m

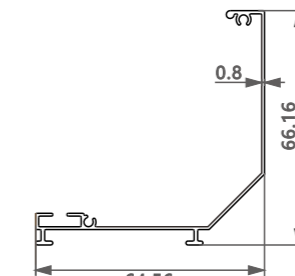

型号/Item No.-11181884
米重/Weight-0.391kg/m

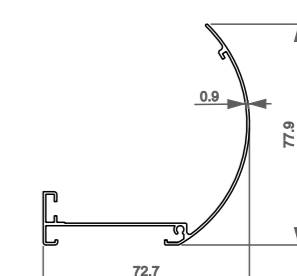

型号/Item No.-1118555
米重/Weight-0.48kg/m

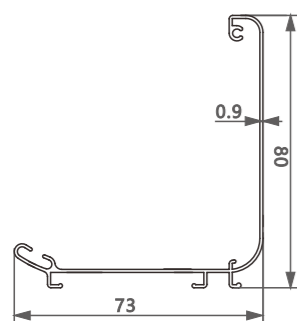

型号/Item No.-11181738
米重/Weight-0.505kg/m

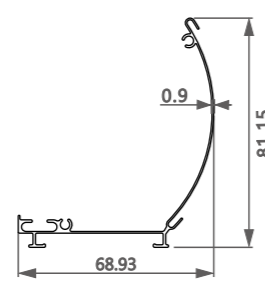

型号/Item No.-1118888
米重/Weight-0.497kg/m

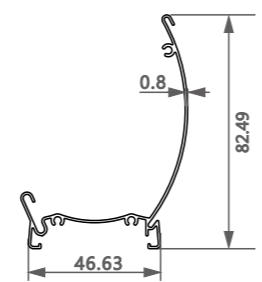

型号/Item No.-1118384
米重/Weight-0.484kg/m

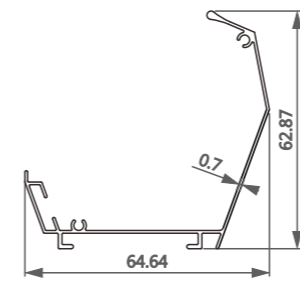

型号/Item No.-11181442
米重/Weight-0.370kg/m

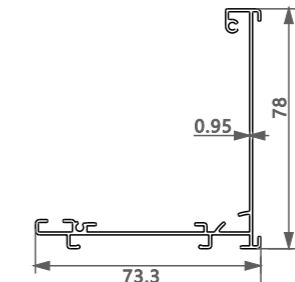

型号/Item No.-11182098
米重/Weight-0.605kg/m

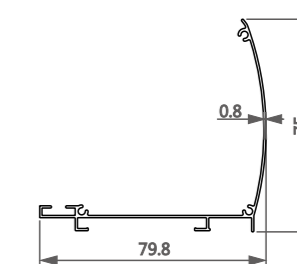

型号/Item No.-11181198
米重/Weight-0.445kg/m

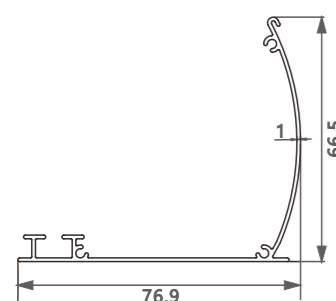

型号/Item No.-1116292
米重/Weight-0.496kg/m

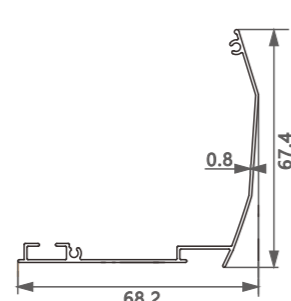

型号/Item No.-11181500
米重/Weight-0.363kg/m

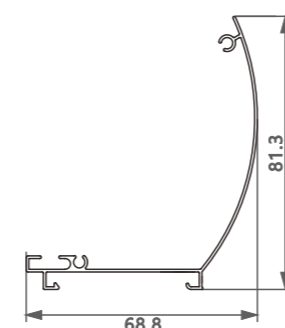

型号/Item No.-11181266
米重/Weight-0.415kg/m

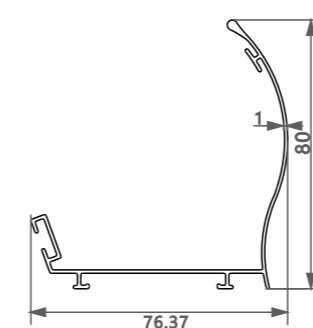

型号/Item No.-11181373
米重/Weight-0.563kg/m

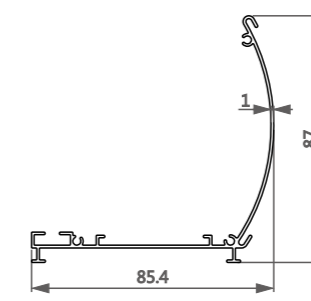

型号/Item No.-1116955
米重/Weight-0.618kg/m

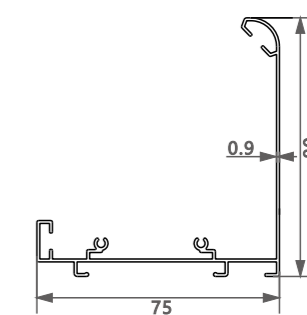

型号/Item No.-11182095
米重/Weight-0.598kg/m

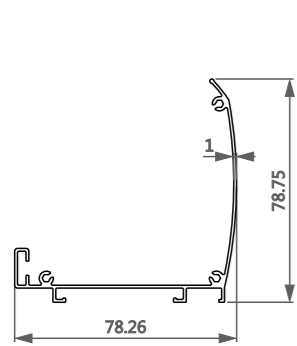

型号/Item No.-11181012
米重/Weight-0.65kg/m

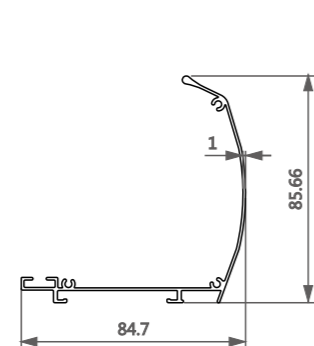

型号/Item No.-11161347
米重/Weight-0.672kg/m

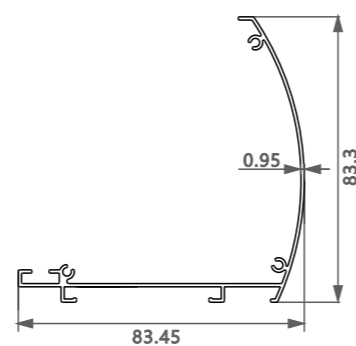

型号/Item No.-11182096
米重/Weight-0.587kg/m

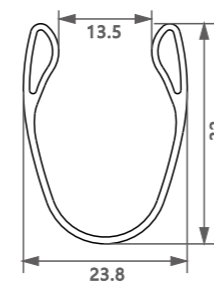

型号/Item No.-11181766
米重/Weight-0.271kg/m

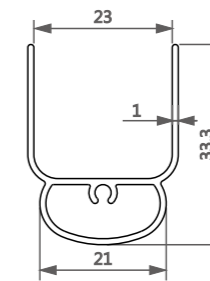

型号/Item No.-1118942
米重/Weight-0.290kg/m

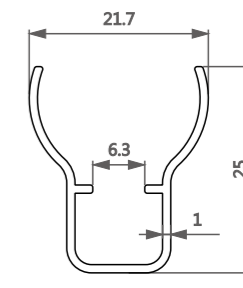

型号/Item No.-11181561
米重/Weight-0.178kg/m

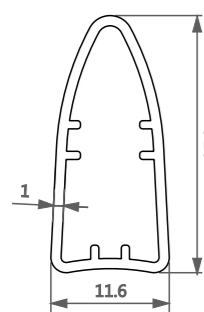

型号/Item No.-1116077
米重/Weight-0.183kg/m

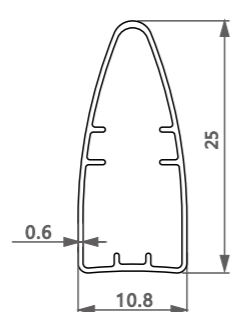

型号/Item No.-11161040
米重/Weight-0.113kg/m

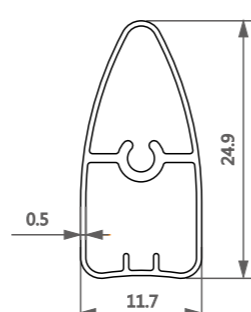

型号/Item No.-11161429
米重/Weight-0.126kg/m

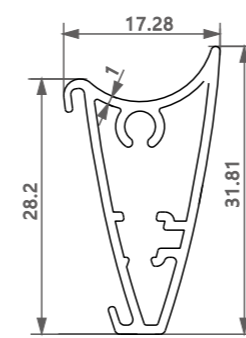

型号/Item No.-11182110
米重/Weight-0.284kg/m

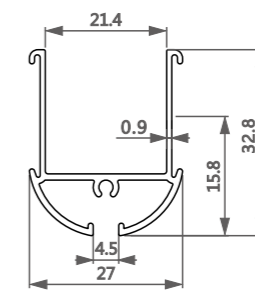

型号/Item No.-1116540
米重/Weight-0.318kg/m

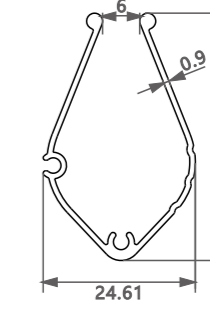

型号/Item No.-11182093
米重/Weight-0.275kg/m

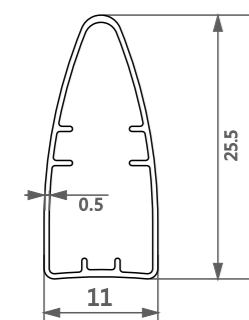

型号/Item No.-11161063
米重/Weight-0.101kg/m

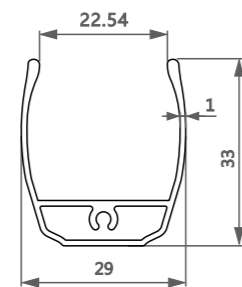

型号/Item No.-11161348
米重/Weight-0.351kg/m

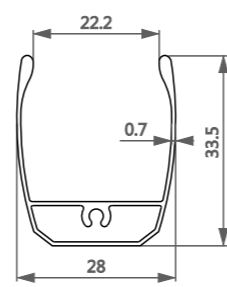

型号/Item No.-11181362
米重/Weight-0.280kg/m

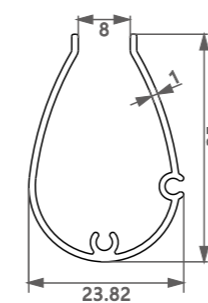

型号/Item No.-11182097
米重/Weight-0.26kg/m

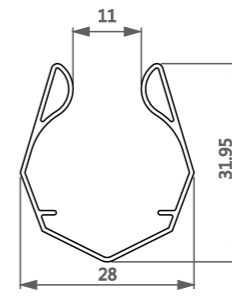

型号/Item No.-11181443
米重/Weight-0.217kg/m

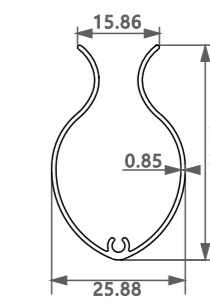

型号/Item No.-11182115
米重/Weight-0.253kg/m

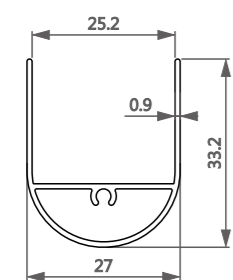

型号/Item No.-11161600
米重/Weight-0.274kg/m

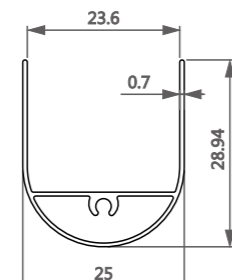

型号/Item No.-11181049
米重/Weight-0.185kg/m

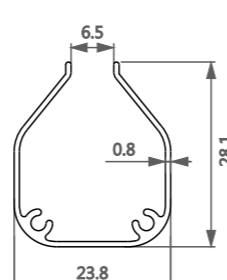

型号/Item No.-11181361
米重/Weight-0.214kg/m

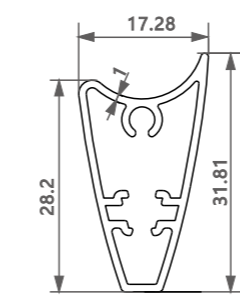

型号/Item No.-11182111
米重/Weight-0.292kg/m

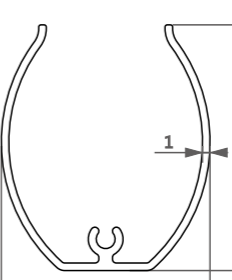

型号/Item No.-11181555
米重/Weight-0.253kg/m

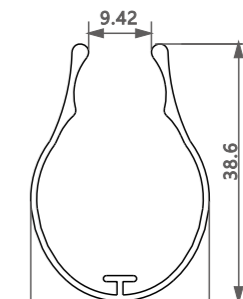

型号/Item No.-11181767
米重/Weight-0.285kg/m

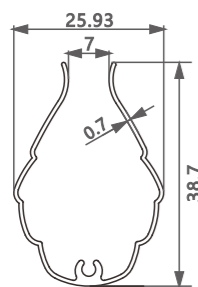

型号/Item No.-11181162
米重/Weight-0.212kg/m

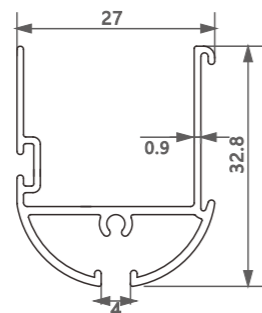

型号/Item No.-1116691
米重/Weight-0.326kg/m

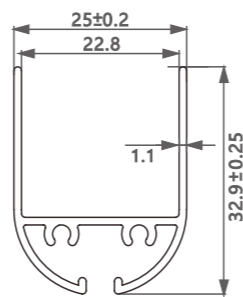

型号/Item No.-11161149
米重/Weight-0.34kg/m

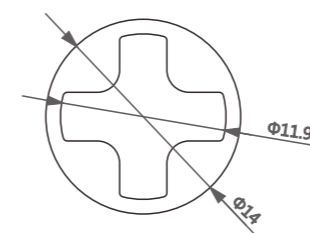

型号/Item No.-1116078
米重/Weight-0.226kg/m

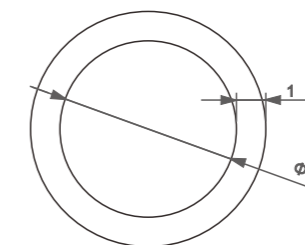

型号/Item No.-6110172
米重/Weight-0.060kg/m

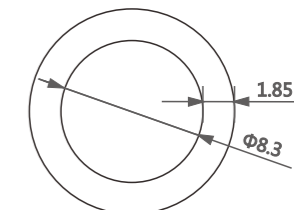

型号/Item No.-6110446
米重/Weight-0.16kg/m

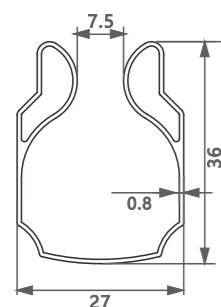

型号/Item No.-11161329
米重/Weight-0.277kg/m

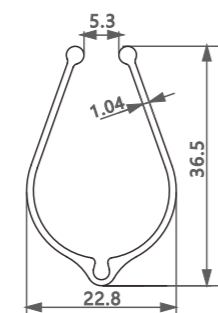

型号/Item No.-11161319
米重/Weight-0.268kg/m

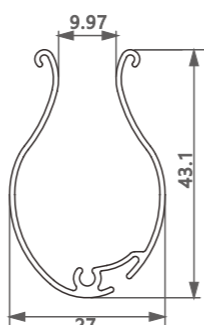

型号/Item No.-11181814
米重/Weight-0.311kg/m

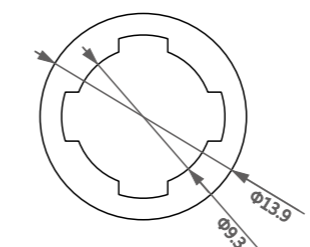

型号/Item No.-11161601
米重/Weight-0.198kg/m

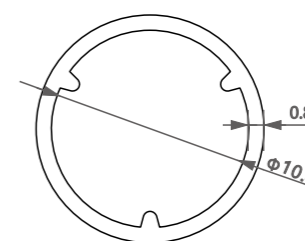

型号/Item No.-11181048
米重/Weight-0.082kg/m

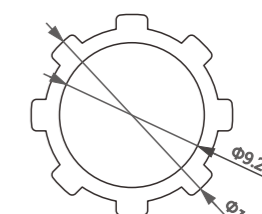

型号/Item No.-11181360
米重/Weight-0.119kg/m

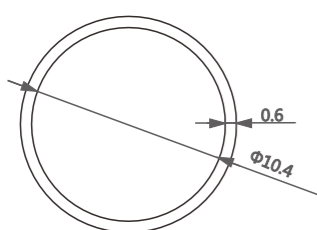

型号/Item No.-6110366
米重/Weight-0.057kg/m

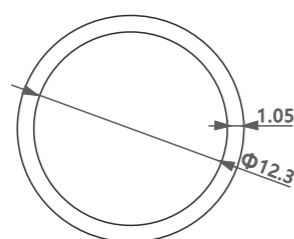

型号/Item No.-6110276
米重/Weight-0.120kg/m

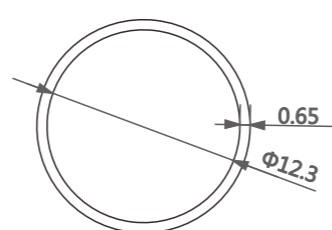

型号/Item No.-6110589
米重/Weight-0.072kg/m

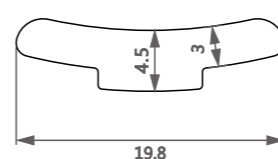

型号/Item No.-1116430
米重/Weight-0.187kg/m

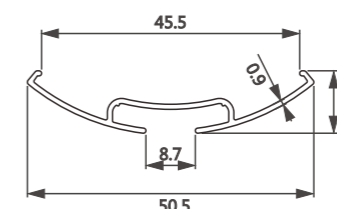

型号/Item No.-1116288
米重/Weight-0.190kg/m

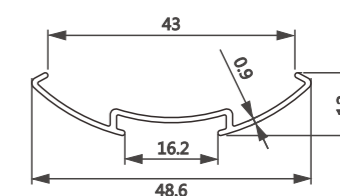

型号/Item No.-11161362
米重/Weight-0.17kg/m

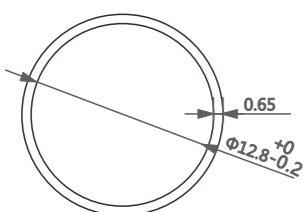

型号/Item No.-6110510
米重/Weight-0.074kg/m

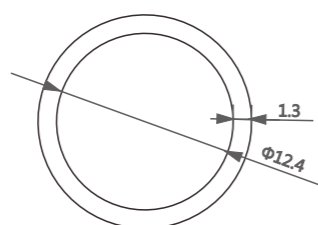

型号/Item No.-611095
米重/Weight-0.153kg/m

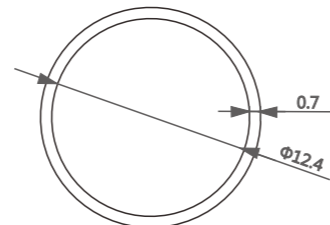

型号/Item No.-6110580
米重/Weight-0.079kg/m

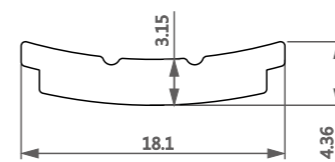

型号/Item No.-11161363
米重/Weight-0.144kg/m

05

Venetian Blinds & Honeycomb Blinds System

百叶百折帘&蜂巢帘系列

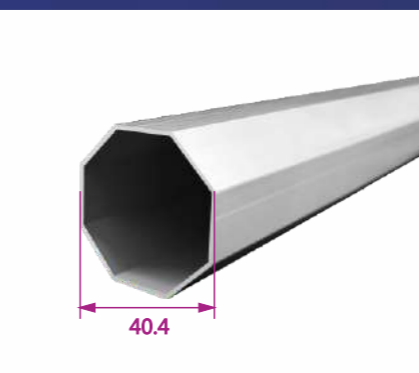

191012



120201

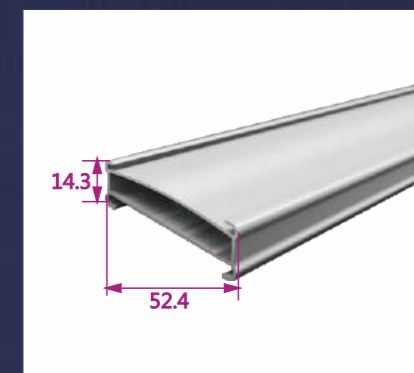

13031330

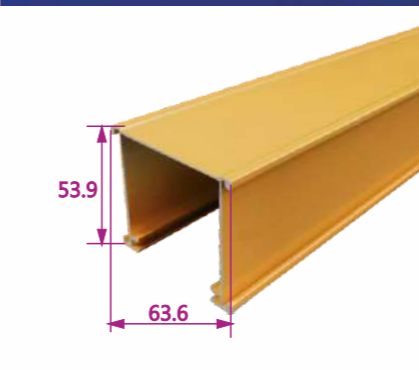

13031331



1202446

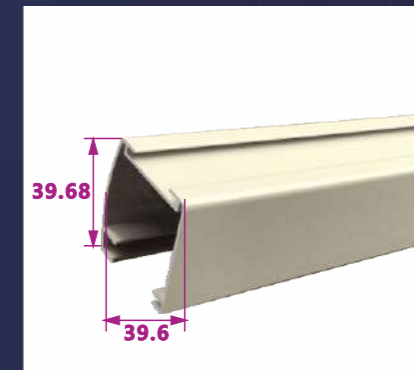

1202486



1202475&1514751



1514751

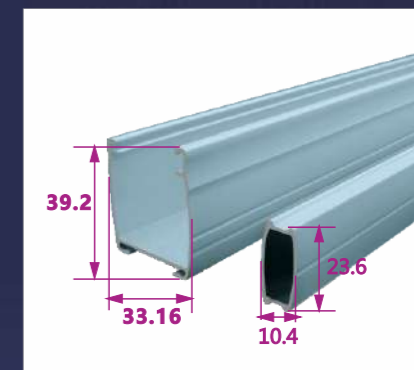

1202446 & 1116474

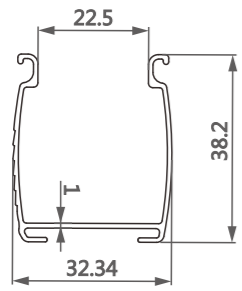

型号/Item No.-1202475
米重/Weight-0.328kg/m

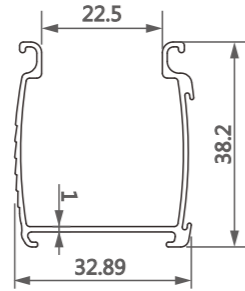

型号/Item No.-1202480
米重/Weight-0.349kg/m

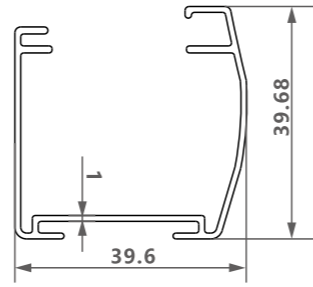

型号/Item No.-1202486
米重/Weight-0.416kg/m

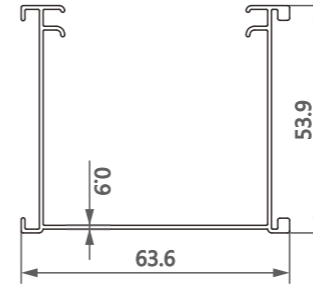

型号/Item No.-13031331
米重/Weight-0.544kg/m

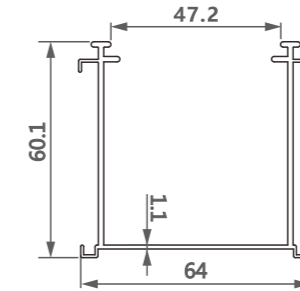

型号/Item No.-120269
米重/Weight-0.772kg/m

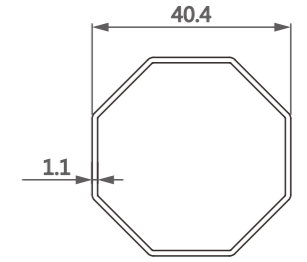

型号/Item No.-191012
米重/Weight-0.387kg/m

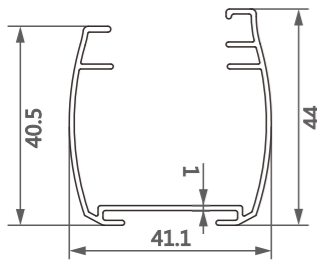

型号/Item No.-13031110
米重/Weight-0.438kg/m

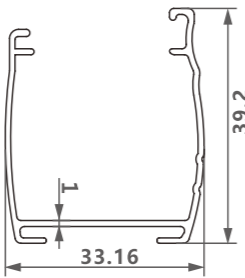

型号/Item No.-1202446
米重/Weight-0.332kg/m

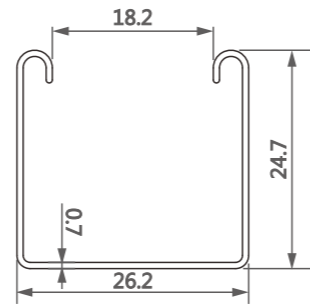

型号/Item No.-120268
米重/Weight-0.158kg/m

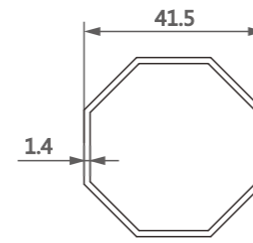

型号/Item No.-1907734
米重/Weight-0.508kg/m

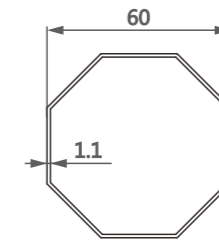

型号/Item No.-1907417
米重/Weight-0.586kg/m

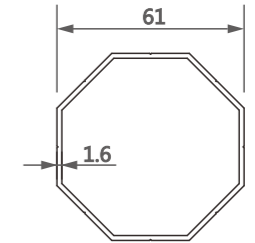

型号/Item No.-1907415
米重/Weight-0.858kg/m

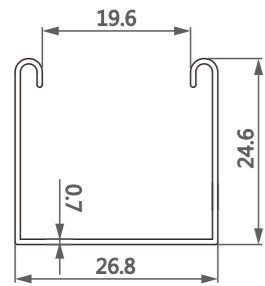

型号/Item No.-1202285
米重/Weight-0.160kg/m

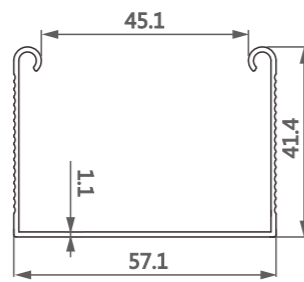

型号/Item No.-1202277
米重/Weight-0.424kg/m

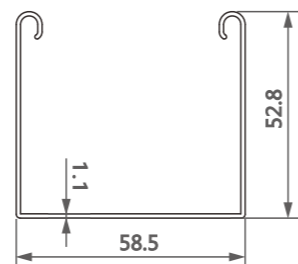

型号/Item No.-120211
米重/Weight-0.537kg/m

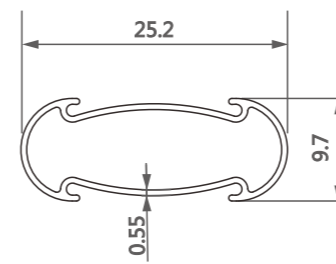

型号/Item No.-11161550
米重/Weight-0.106kg/m

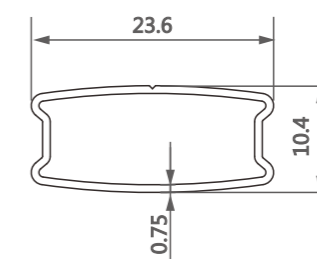

型号/Item No.-1116474
米重/Weight-0.128kg/m

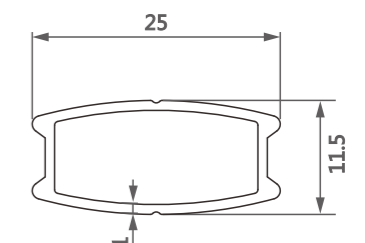

型号/Item No.-11161185
米重/Weight-0.182kg/m

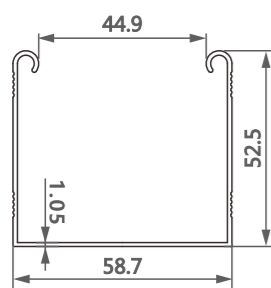

型号/Item No.-1303907
米重/Weight-0.545kg/m

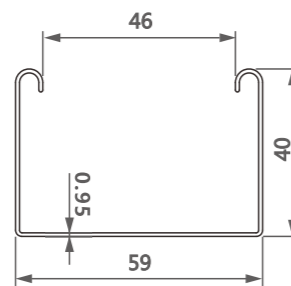

型号/Item No.-120219
米重/Weight-0.377kg/m

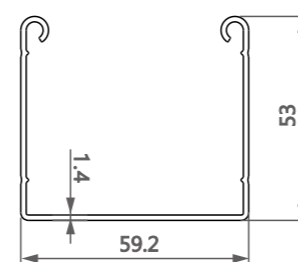

型号/Item No.-120201
米重/Weight-0.680kg/m

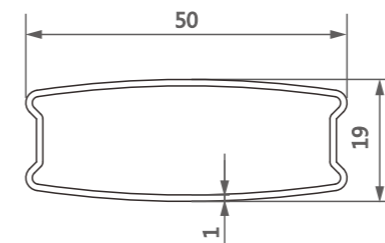

型号/Item No.-11161547
米重/Weight-0.348kg/m

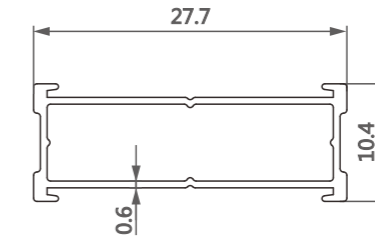

型号/Item No.-11181333
米重/Weight-0.141kg/m

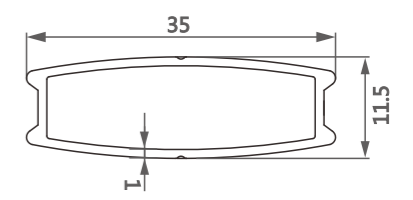

型号/Item No.-11161349
米重/Weight-0.237kg/m

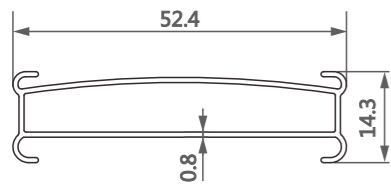

型号/Item No.-13031330
 米重/Weight-0.301kg/m

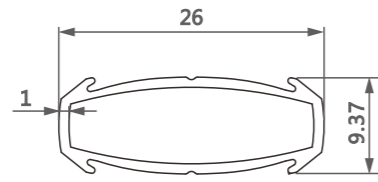

型号/Item No.-11181080
 米重/Weight-0.169kg/m

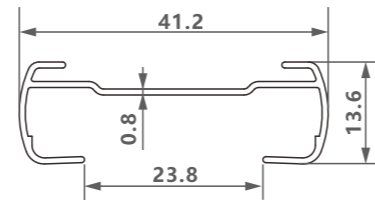

型号/Item No.-1514714
 米重/Weight-0.193kg/m

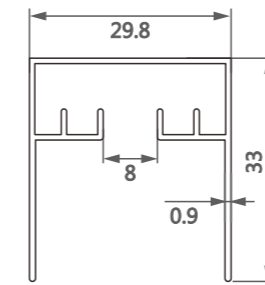

型号/Item No.-19071282
 米重/Weight-0.293kg/m

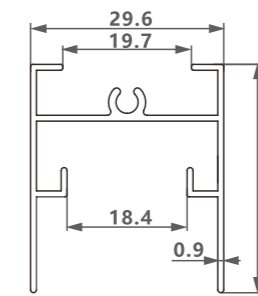

型号/Item No.-1303755-0.9
 米重/Weight-0.331kg/m

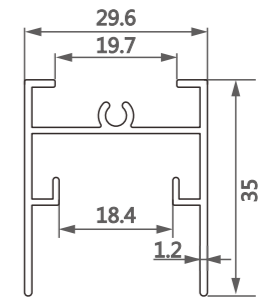

型号/Item No.-1303755
 米重/Weight-0.399kg/m

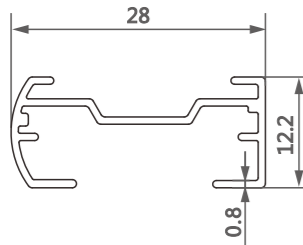

型号/Item No.-1514751
 米重/Weight-0.163kg/m

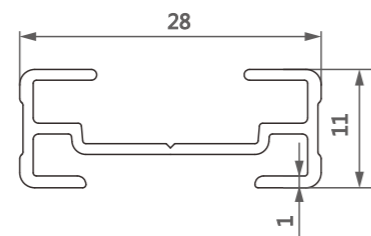

型号/Item No.-1514606
 米重/Weight-0.201kg/m

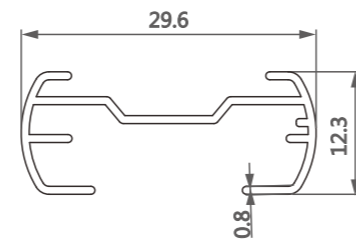

型号/Item No.-1514681
 米重/Weight-0.165kg/m

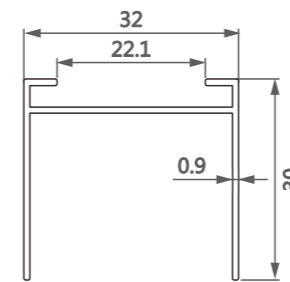

型号/Item No.-1303757
 米重/Weight-0.243kg/m

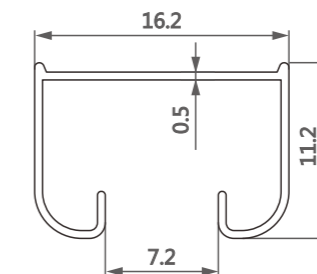

型号/Item No.-1303758
 米重/Weight-0.065kg/m

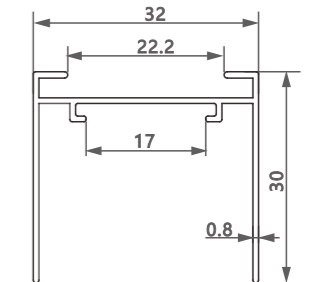

型号/Item No.-13031581
 米重/Weight-0.234kg/m

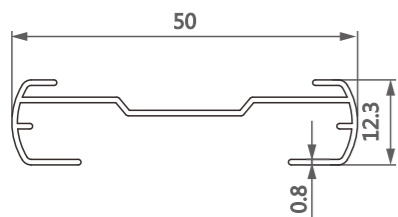

型号/Item No.-1514682
 米重/Weight-0.245kg/m

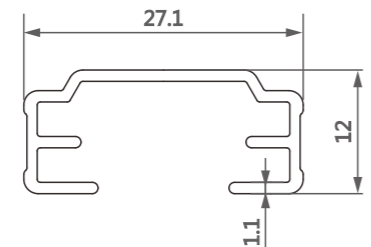

型号/Item No.-1514239
 米重/Weight-0.197kg/m

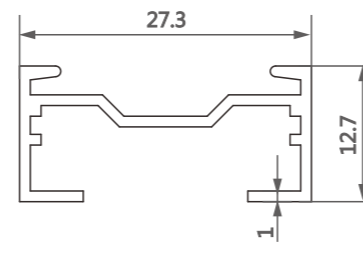

型号/Item No.-1514112
 米重/Weight-0.198kg/m

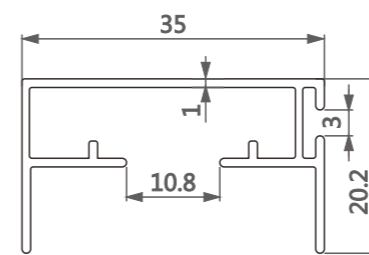

型号/Item No.-13031048
 米重/Weight-0.278kg/m

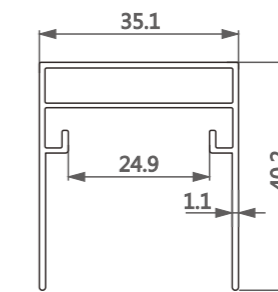

型号/Item No.-13031049
 米重/Weight-0.433kg/m

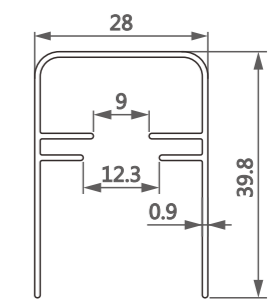

型号/Item No.-13031380
 米重/Weight-0.328kg/m

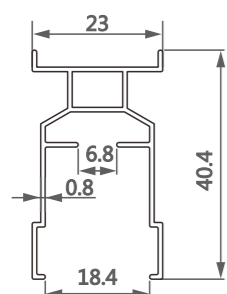

型号/Item No.-1303756
 米重/Weight-0.292kg/m

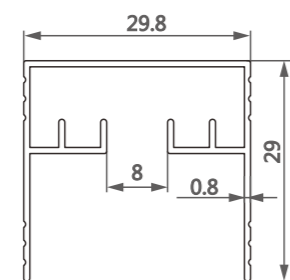

型号/Item No.-79081085
 米重/Weight-0.259kg/m

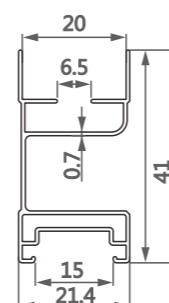

型号/Item No.-1514898
 米重/Weight-0.288kg/m

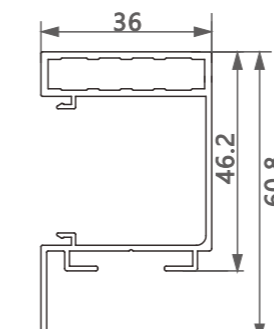

型号/Item No.-19071463
 米重/Weight-0.699kg/m

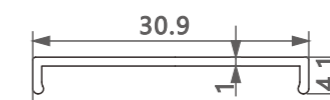

型号/Item No.-19071485
 米重/Weight-0.101kg/m

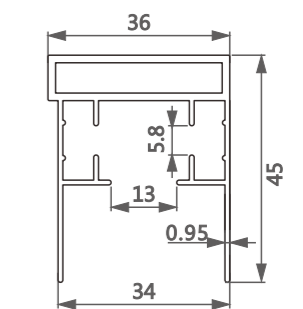

型号/Item No.-13031052
 米重/Weight-0.634kg/m

05 百叶百折帘&蜂巢帘系列 Venetian Blinds & Honeycomb Blinds System

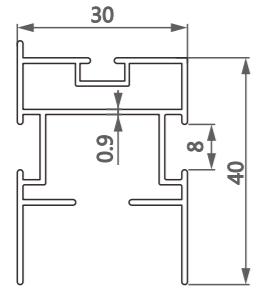

型号/Item No.-13031050
米重/Weight-0.484 kg/m

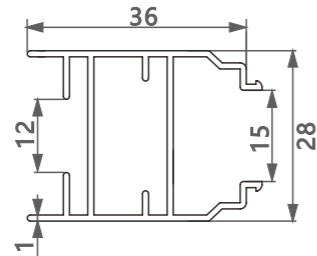

型号/Item No.-13031242
米重/Weight-0.435kg/m

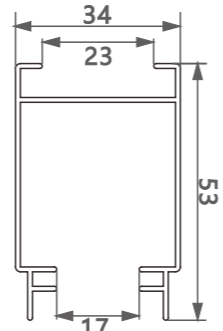

型号/Item No.-13031243
米重/Weight-0.465kg/m

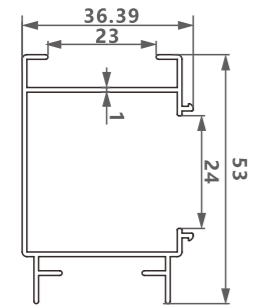

型号/Item No.-13031244
米重/Weight-0.461kg/m

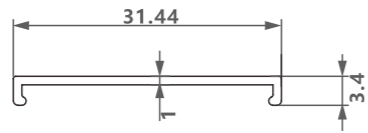

型号/Item No.-13031245
米重/Weight-0.101kg/m

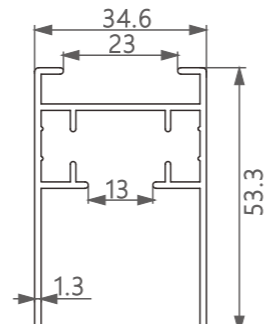

型号/Item No.-13031246
米重/Weight-0.639kg/m

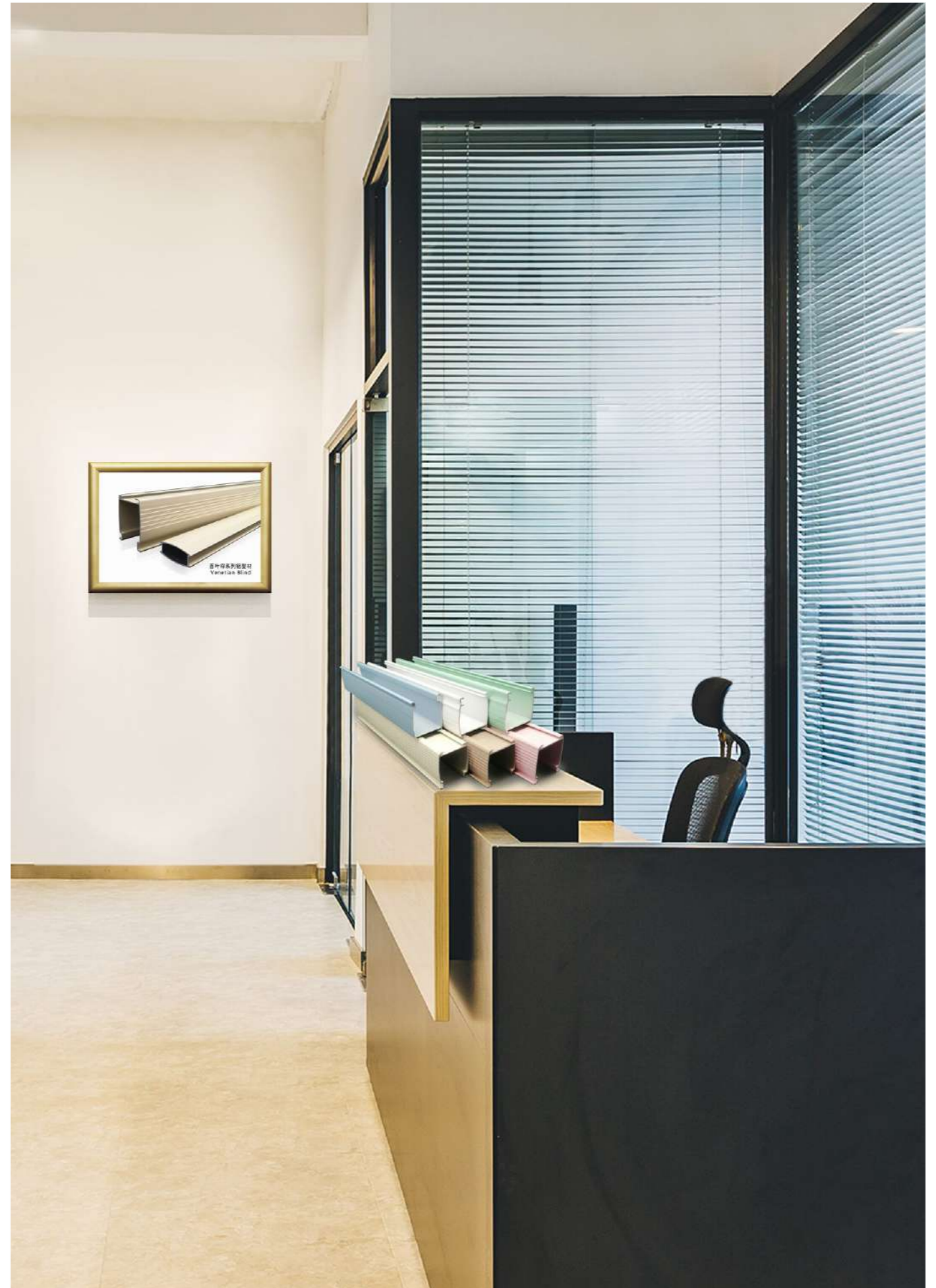

06 Vertical Blinds & Roman Blinds & Panel Track System

垂直帘&罗马帘&屏风帘系列

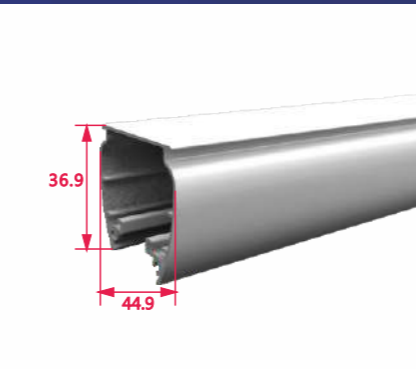

13031453



130345

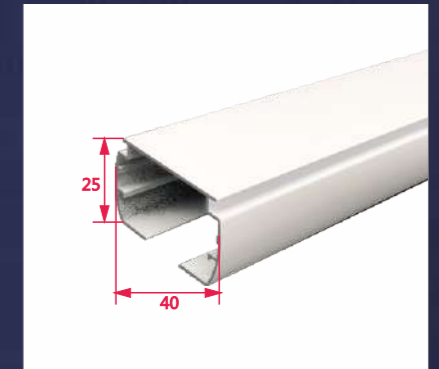

130325

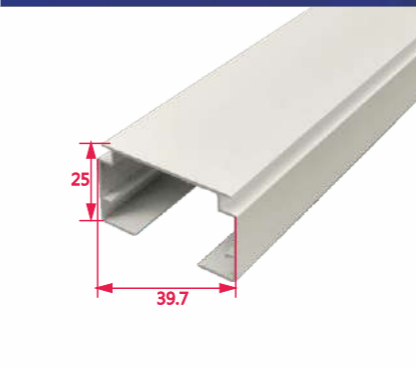

1303659

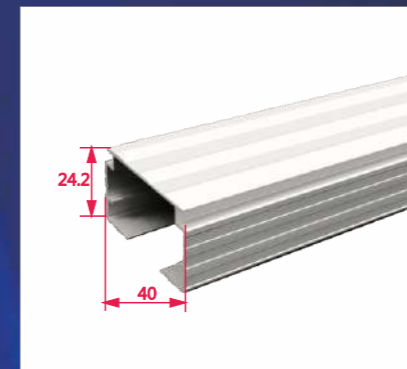

1303225

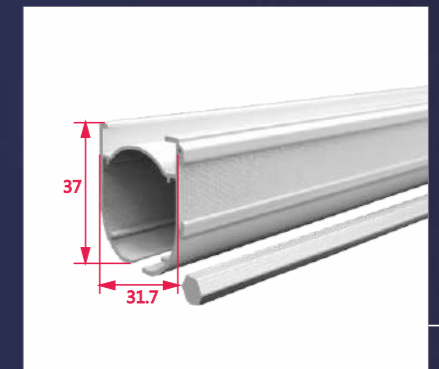

1118511



1514178



1514180

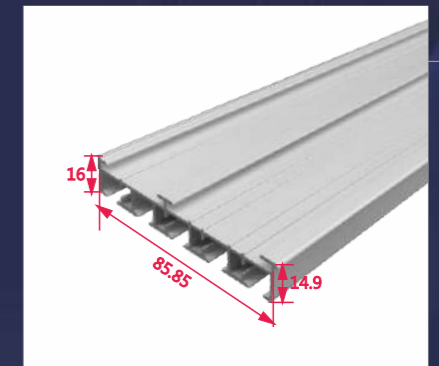

1514179

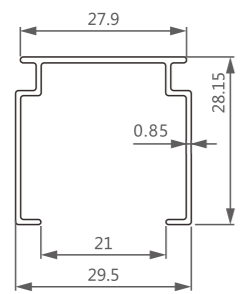

型号/Item No.-1514902
米重/Weight-0.233kg/m

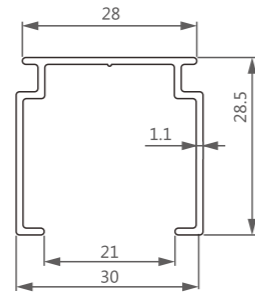

型号/Item No.-130362
米重/Weight-0.288kg/m

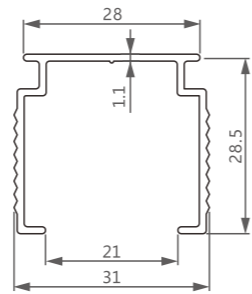

型号/Item No.-1303163
米重/Weight-0.311 kg/m

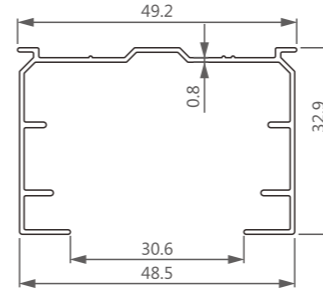

型号/Item No.-1514170
米重/Weight-0.341 kg/m

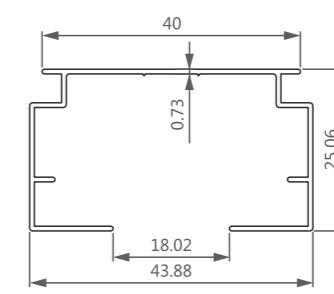

型号/Item No.-1303271
米重/Weight-0.257kg/m

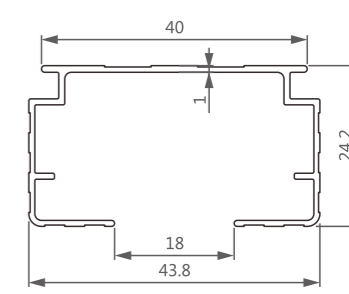

型号/Item No.-1303225
米重/Weight-0.292kg/m

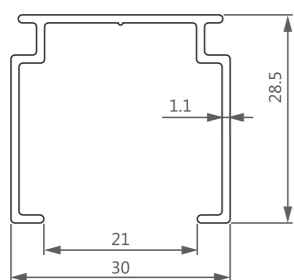

型号/Item No.-130362
米重/Weight-0.288kg/m

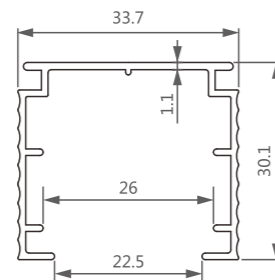

型号/Item No.-130306
米重/Weight-0.324kg/m

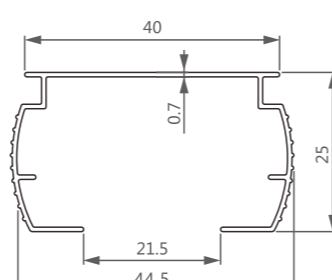

型号/Item No.-1303616
米重/Weight-0.231kg/m

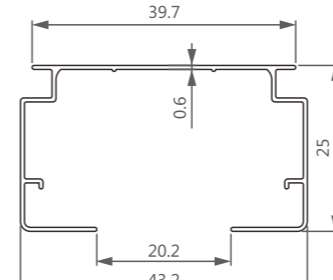

型号/Item No.-1303659
米重/Weight-0.208kg/m

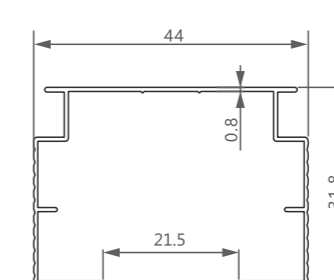

型号/Item No.-130356
米重/Weight-0.314kg/m

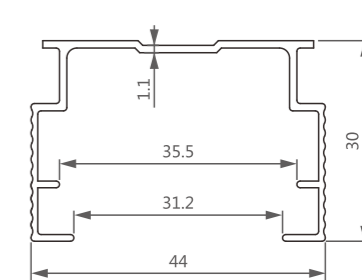

型号/Item No.-130302
米重/Weight-0.345kg/m

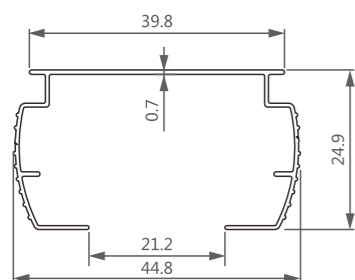

型号/Item No.-1303855
米重/Weight-0.212kg/m

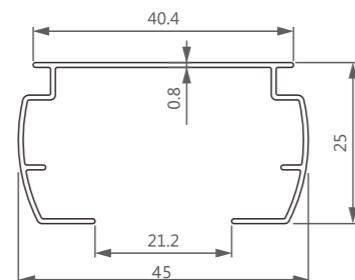

型号/Item No.-1303621
米重/Weight-0.246kg/m

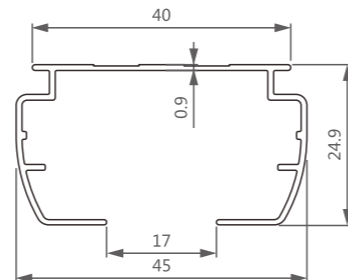

型号/Item No.-1303251
米重/Weight-0.293kg/m

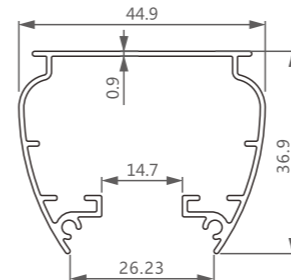

型号/Item No.-13031453
米重/Weight-0.425kg/m

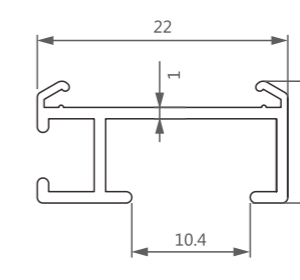

型号/Item No.-1907180
米重/Weight-0.146kg/m

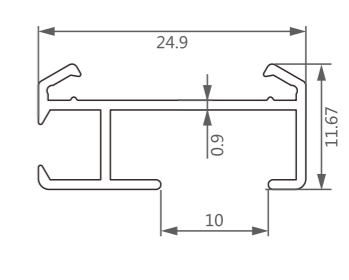

型号/Item No.-1907290
米重/Weight-0.159kg/m

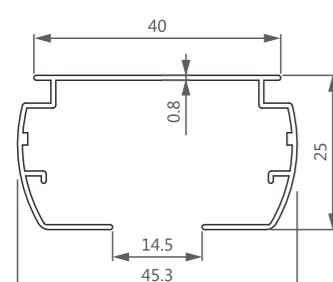

型号/Item No.-130325
米重/Weight-0.288kg/m

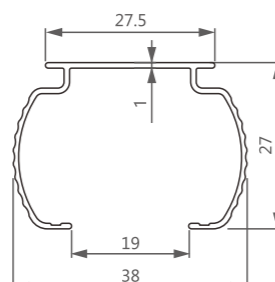

型号/Item No.-1303794
米重/Weight-0.227kg/m

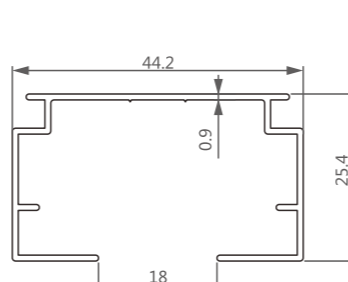

型号/Item No.-130345
米重/Weight-0.317kg/m

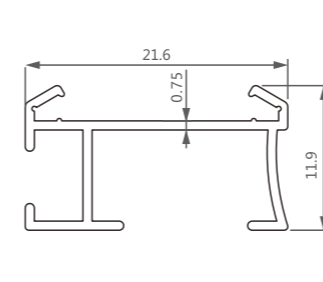

型号/Item No.-110173
米重/Weight-0.121kg/m

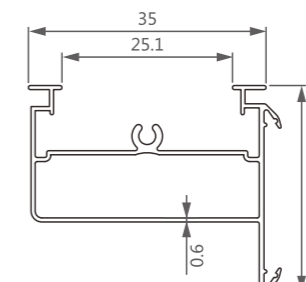

型号/Item No.-110134
米重/Weight-0.261kg/m

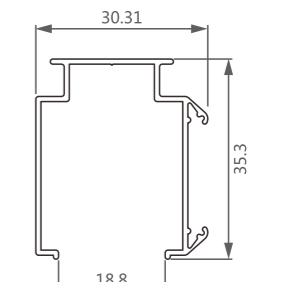

型号/Item No.-1116056
米重/Weight-0.286kg/m

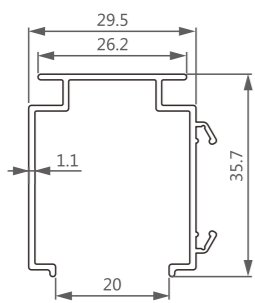

型号/Item No.-1514592
米重/Weight-0.353kg/m

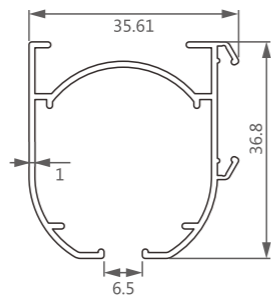

型号/Item No.-1514355
米重/Weight-0.403kg/m

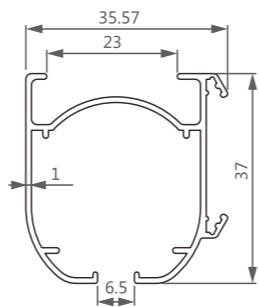

型号/Item No.-1116055
米重/Weight-0.409kg/m

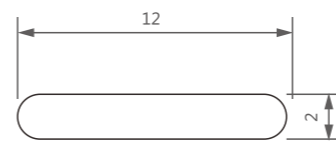

型号/Item No.-920010
米重/Weight-0.063kg/m

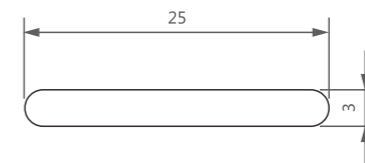

型号/Item No.-920021
米重/Weight-0.199kg/m

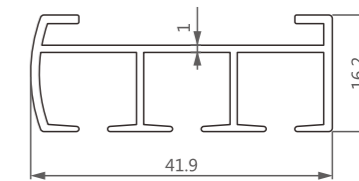

型号/Item No.-151471
米重/Weight-0.355kg/m

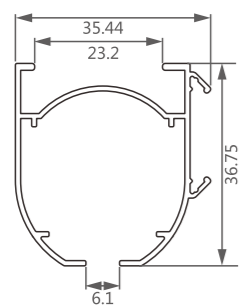

型号/Item No.-13031490
米重/Weight-0.368kg/m

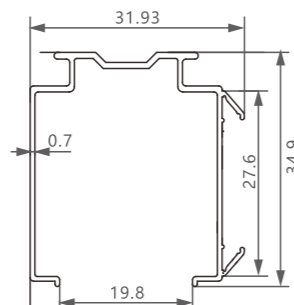

型号/Item No.-1514915
米重/Weight-0.248kg/m

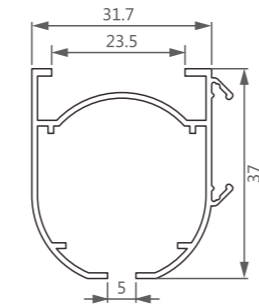

型号/Item No.-1118511
米重/Weight-0.392kg/m

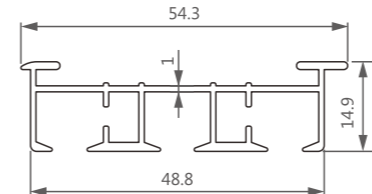

型号/Item No.-1514956
米重/Weight-0.415kg/m

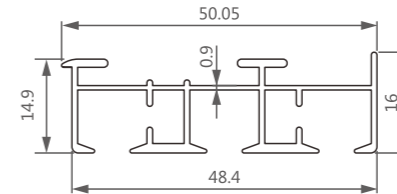

型号/Item No.-1514178
米重/Weight-0.388kg/m

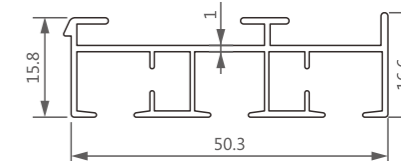

型号/Item No.-1514180
米重/Weight-0.548kg/m

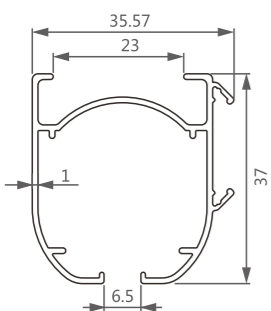

型号/Item No.-13031485
米重/Weight-0.396kg/m

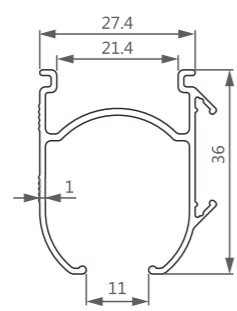

型号/Item No.-1116531
米重/Weight-0.360kg/m

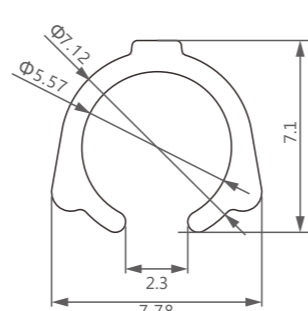

型号/Item No.-1907687
米重/Weight-0.045kg/m

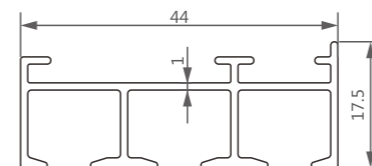

型号/Item No.-1514859
米重/Weight-0.370kg/m

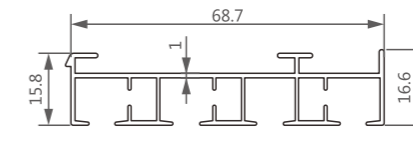

型号/Item No.-1514832
米重/Weight-0.508kg/m

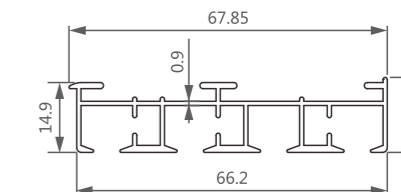

型号/Item No.-1514180
米重/Weight-0.548kg/m

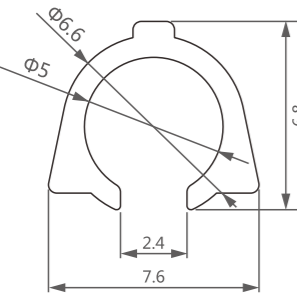

型号/Item No.-1118965
米重/Weight-0.045kg/m

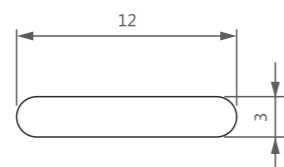

型号/Item No.-920011
米重/Weight-0.093kg/m

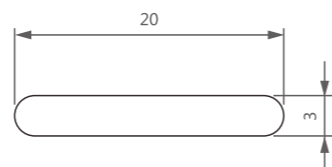

型号/Item No.-920046
米重/Weight-0.159kg/m

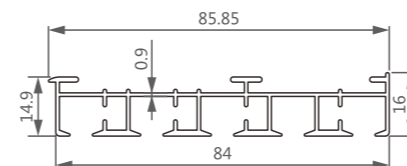

型号/Item No.-1514179
米重/Weight-0.672kg/m

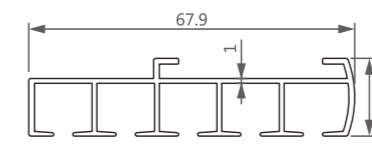

型号/Item No.-151472
米重/Weight-0.522kg/m

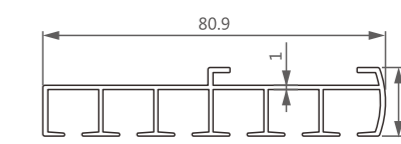

型号/Item No.-151477
米重/Weight-0.605kg/m

06 垂直帘&罗马帘&屏风帘系列

Vertical Blinds & Roman Blinds & Panel Track System

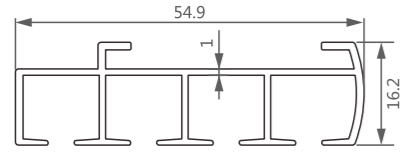

型号/Item No.-151478
米重/Weight-0.438kg/m

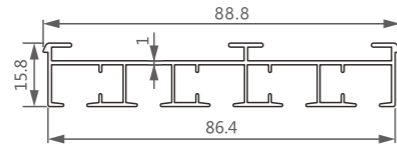

型号/Item No.-1514833
米重/Weight-0.617kg/m

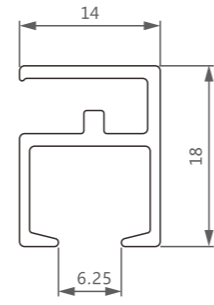

型号/Item No.-1514858
米重/Weight-0.198kg/m

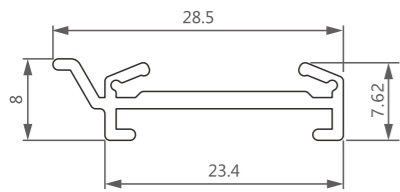

型号/Item No.-151461
米重/Weight-0.179kg/m

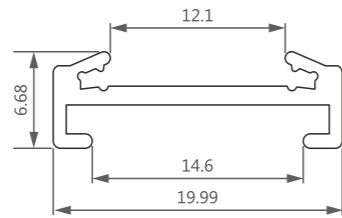

型号/Item No.-11181288
米重/Weight-0.118kg/m

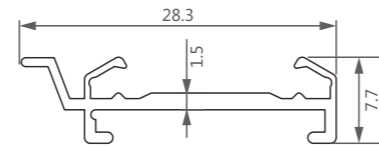

型号/Item No.-1514136
米重/Weight-0.139kg/m

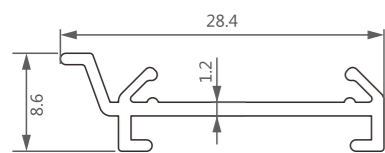

型号/Item No.-13031030
米重/Weight-0.148kg/m

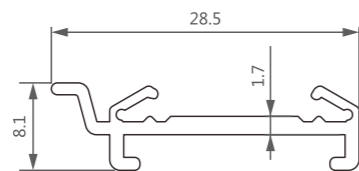

型号/Item No.-151492
米重/Weight-0.175kg/m



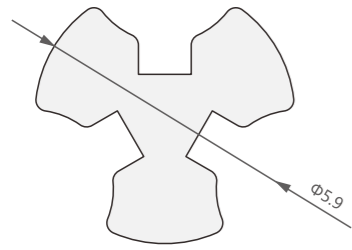

型号/Item No.-1303651
米重/Weight-0.043kg/m

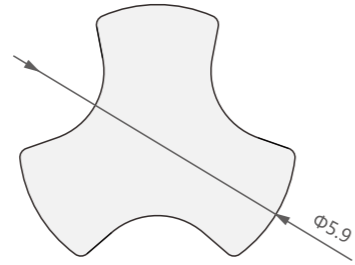

型号/Item No.-1303169
米重/Weight-0.050kg/m

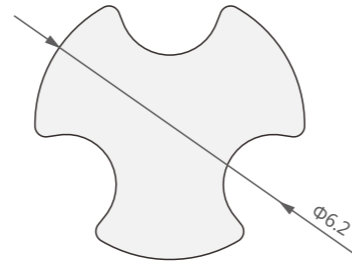

型号/Item No.-1303170
米重/Weight-0.059 kg/m

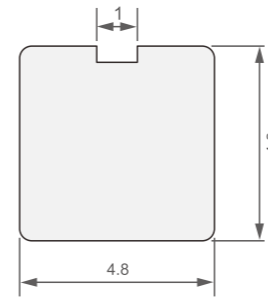

型号/Item No.-1303209
米重/Weight-0.062kg/m

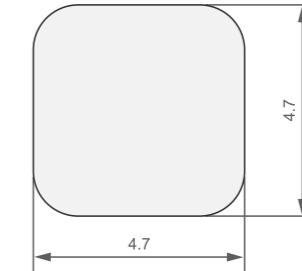

型号/Item No.-1303646
米重/Weight-0.058kg/m

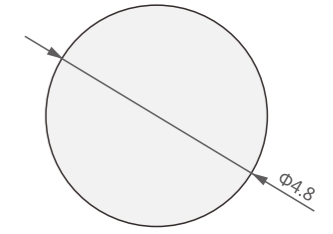

型号/Item No.-130343
米重/Weight-0.049kg/m

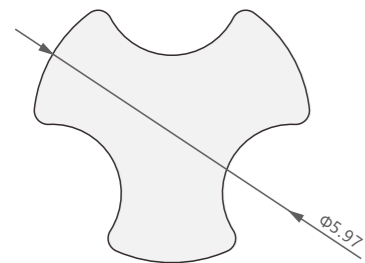

型号/Item No.-130313
米重/Weight-0.050kg/m

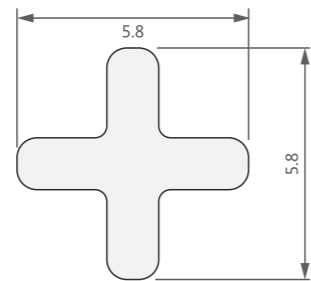

型号/Item No.-1303658
米重/Weight-0.036kg/m

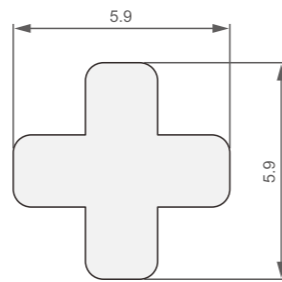

型号/Item No.-130312
米重/Weight-0.053kg/m

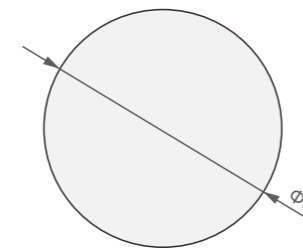

型号/Item No.-130344
米重/Weight-0.077kg/m

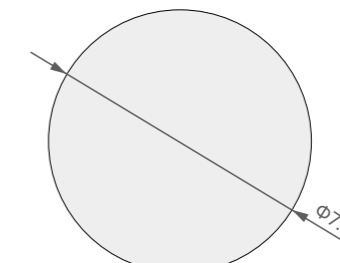

型号/Item No.-911279
米重/Weight-0.121kg/m

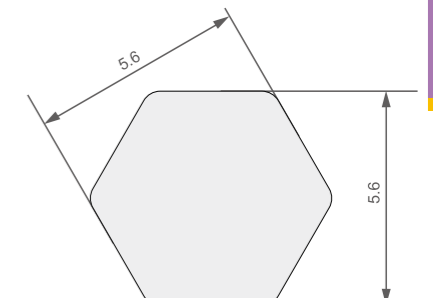

型号/Item No.-1303748
米重/Weight-0.074kg/m

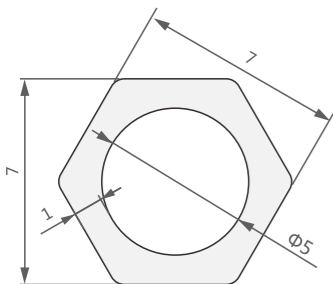

型号/Item No.-151404
米重/Weight-0.062kg/m

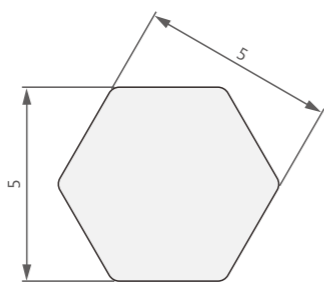

型号/Item No.-111317
米重/Weight-0.059kg/m

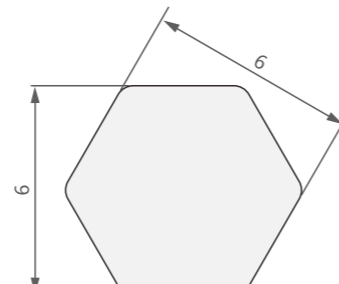

型号/Item No.-191137
米重/Weight-0.085kg/m



130312

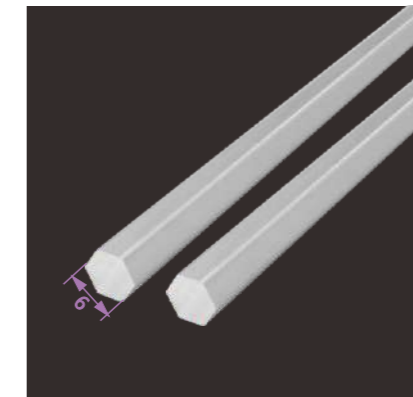

191137



130313

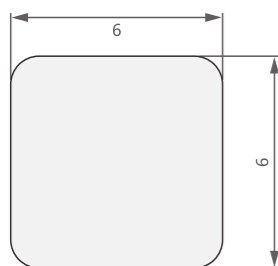

型号/Item No.-151417
米重/Weight-0.097kg/m

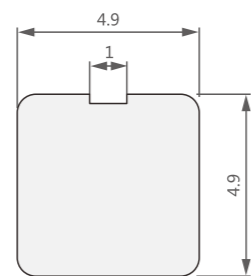

型号/Item No.-1514819
米重/Weight-0.064kg/m

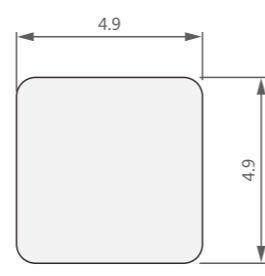

型号/Item No.-151401
米重/Weight-0.065kg/m

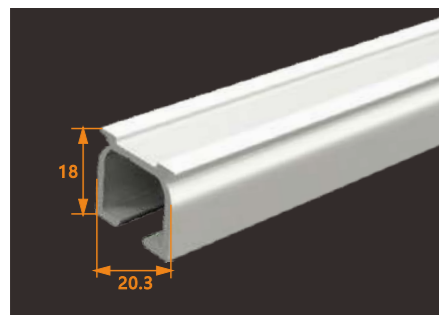

1514948

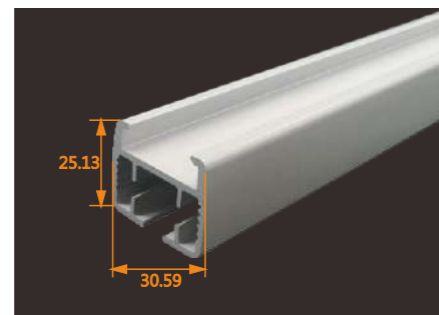

1303633

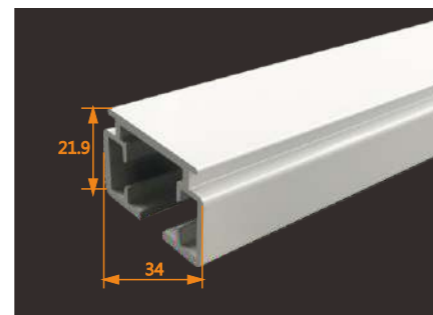

1303442



11181013

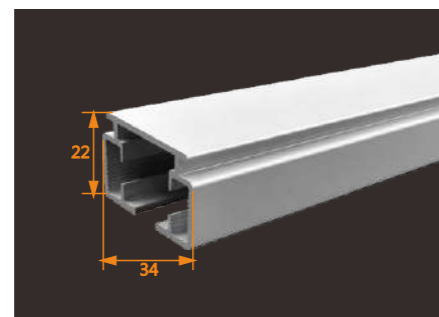

13031150

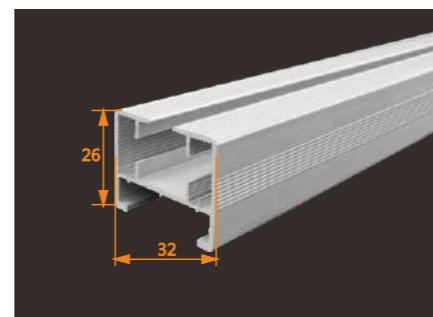

1514575

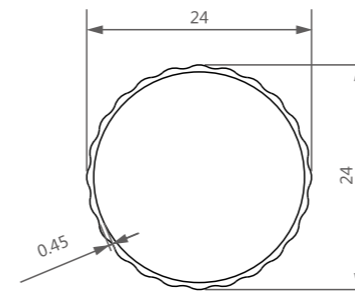

型号/Item No.-631104
米重/Weight-0.119kg/m

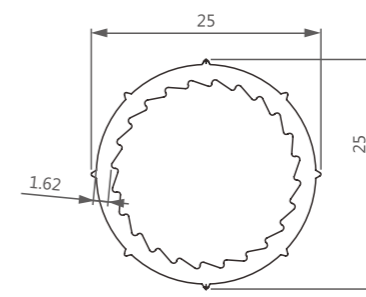

型号/Item No.-111101
米重/Weight-0.381kg/m

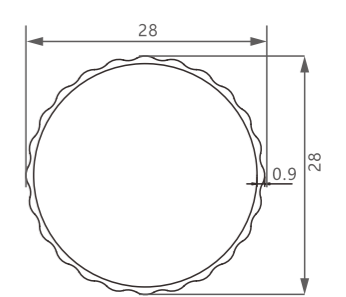

型号/Item No.-631152
米重/Weight-0.161kg/m

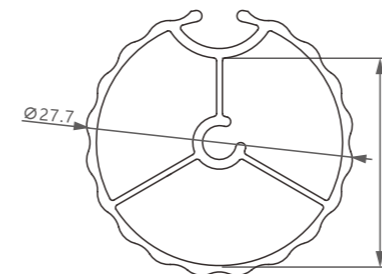

型号/Item No.-11161242
米重/Weight-0.302kg/m

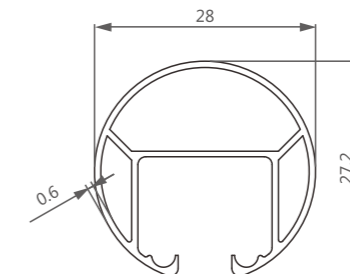

型号/Item No.-150551
米重/Weight-0.284kg/m

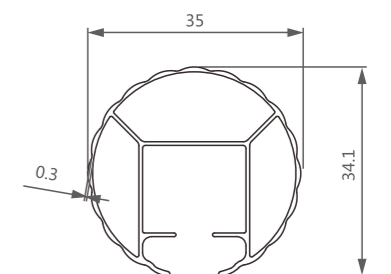

型号/Item No.-151409
米重/Weight-0.307kg/m

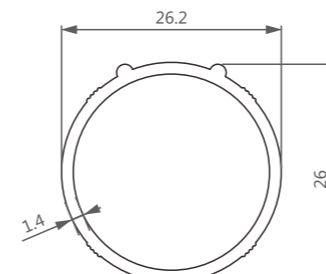

型号/Item No.-1118458
米重/Weight-0.310kg/m

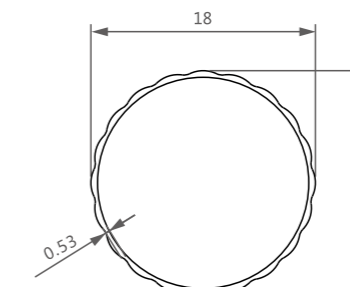

型号/Item No.-631108
米重/Weight-0.065kg/m

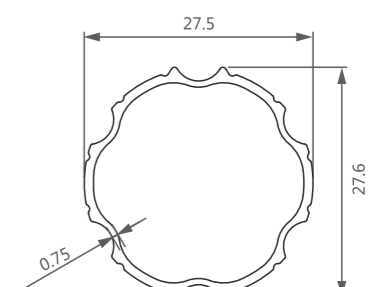

型号/Item No.-11181059
米重/Weight-0.24kg/m

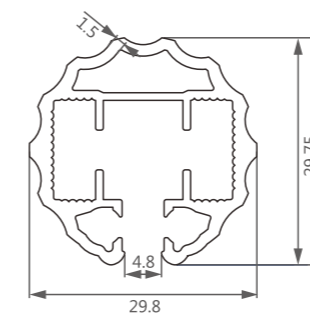

型号/Item No.-13031423
米重/Weight-0.571kg/m

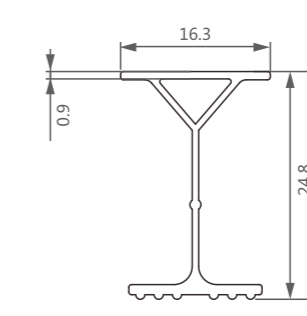

型号/Item No.-1404137
米重/Weight-0.152kg/m

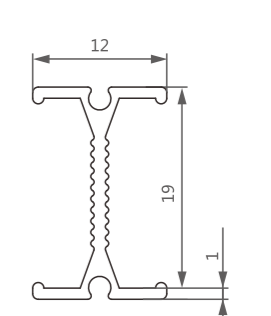

型号/Item No.-1404175
米重/Weight-0.13kg/m

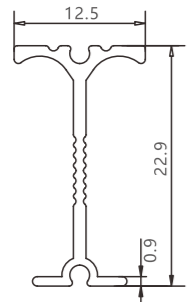

型号/Item No.-1404170
米重/Weight-0.125kg/m

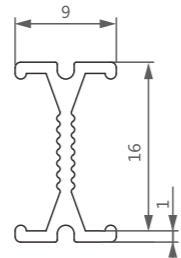

型号/Item No.-1404128
米重/Weight-0.109kg/m

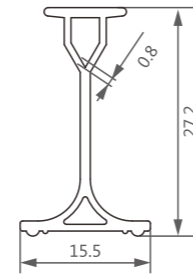

型号/Item No.-1404121
米重/Weight-0.179kg/m

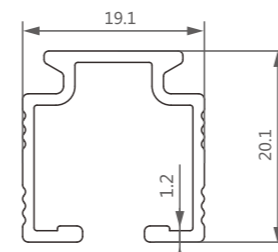

型号/Item No.-1514588
米重/Weight-0.234kg/m

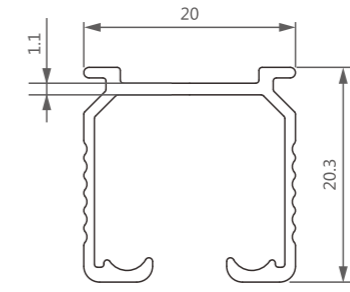

型号/Item No.-1303844
米重/Weight-0.204kg/m

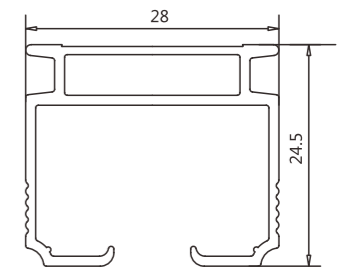

型号/Item No.-1514732
米重/Weight-0.342kg/m

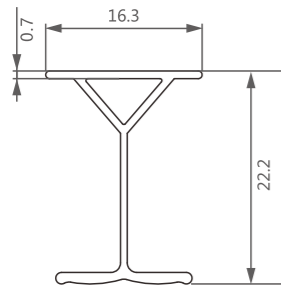

型号/Item No.-140491
米重/Weight-0.130kg/m

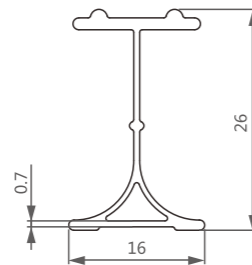

型号/Item No.-1404189
米重/Weight-0.167kg/m

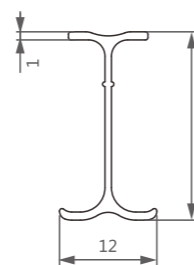

型号/Item No.-1404180
米重/Weight-0.109kg/m

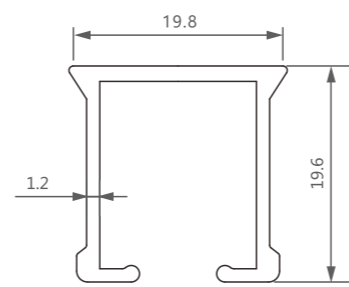

型号/Item No.-1514154
米重/Weight-0.235kg/m

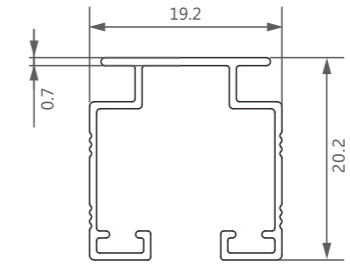

型号/Item No.-13031308
米重/Weight-0.162kg/m

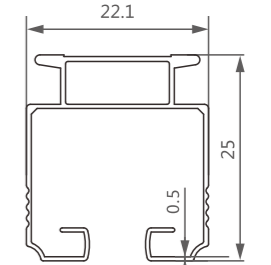

型号/Item No.-13031161
米重/Weight-0.182kg/m

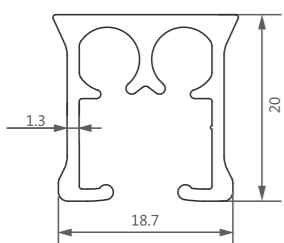

型号/Item No.-1303523
米重/Weight-0.329kg/m

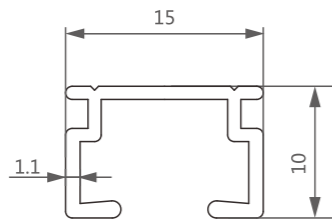

型号/Item No.-1303201
米重/Weight-0.120kg/m

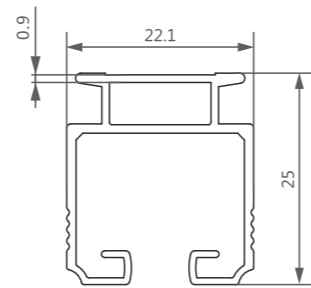

型号/Item No.-13031162
米重/Weight-0.294kg/m

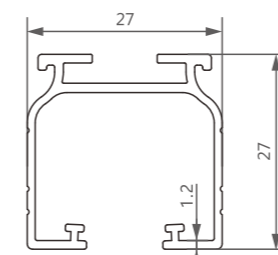

型号/Item No.-13031422
米重/Weight-0.351kg/m

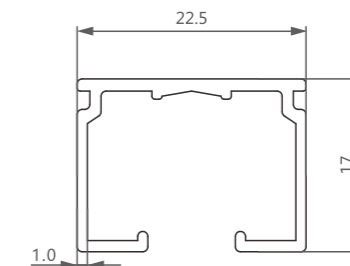

型号/Item No.-13031425
米重/Weight-0.215kg/m

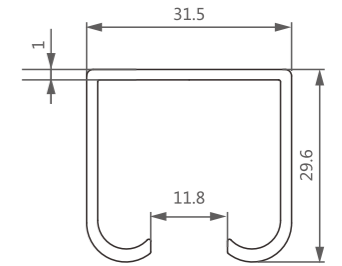

型号/Item No.-1202173
米重/Weight-0.468kg/m

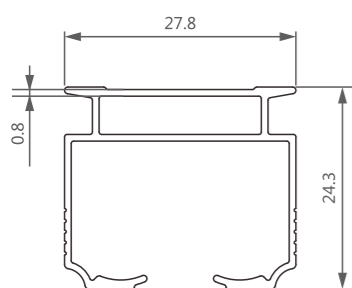

型号/Item No.-1514770
米重/Weight-0.271kg/m

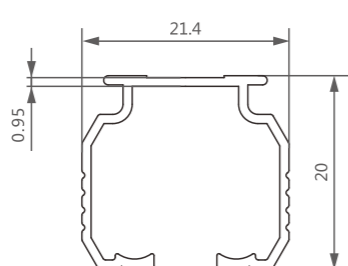

型号/Item No.-1303900
米重/Weight-0.186kg/m

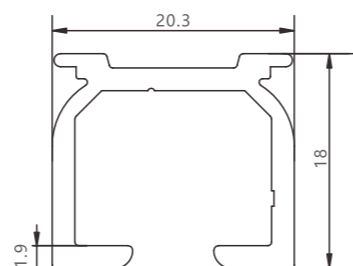

型号/Item No.-1514948
米重/Weight-0.307kg/m

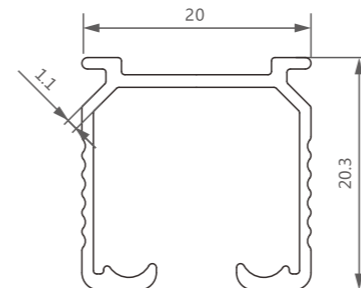

型号/Item No.-1303844
米重/Weight-0.204kg/m

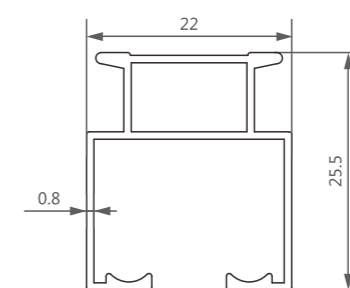

型号/Item No.-1303898
米重/Weight-0.244kg/m

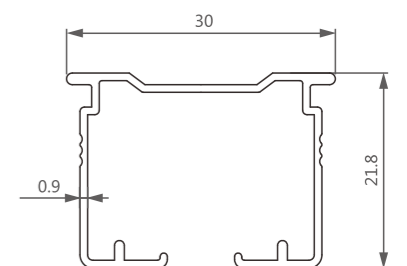

型号/Item No.-13031139
米重/Weight-0.233kg/m

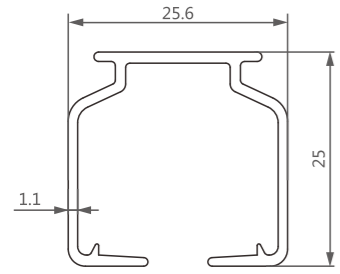

型号/Item No.-13031432
米重/Weight-0.287kg/m

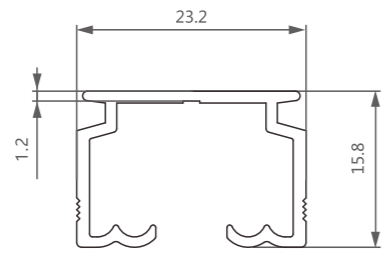

型号/Item No.-13031323
米重/Weight-0.226kg/m

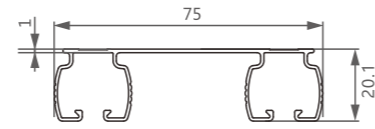

型号/Item No.-151407
米重/Weight-0.470kg/m

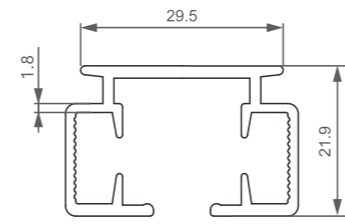

型号/Item No.-13031001
米重/Weight-0.496kg/m

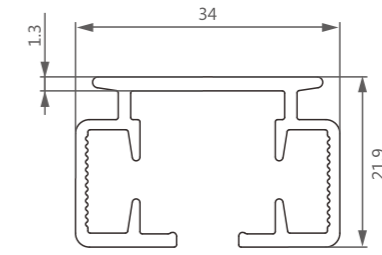

型号/Item No.-13031373
米重/Weight-0.513kg/m

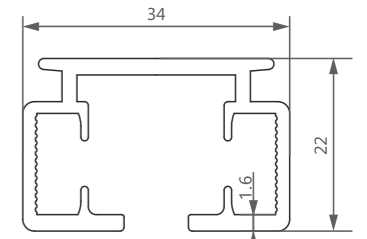

型号/Item No.-13031007
米重/Weight-0.565kg/m

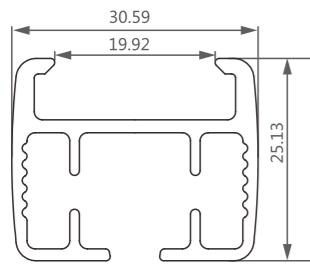

型号/Item No.-1303633
米重/Weight-0.530kg/m

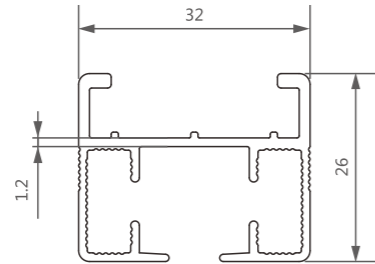

型号/Item No.-1514575
米重/Weight-0.444kg/m

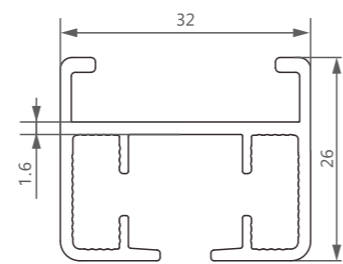

型号/Item No.-13031066
米重/Weight-0.512kg/m

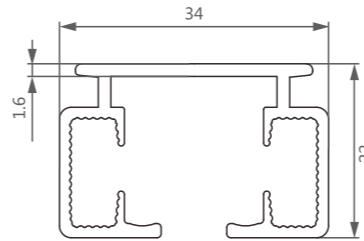

型号/Item No.-13031150
米重/Weight-0.473kg/m

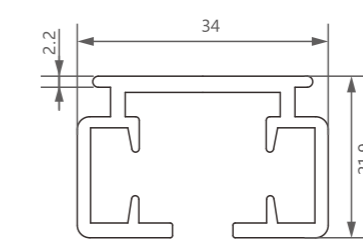

型号/Item No.-1303442
米重/Weight-0.579kg/m

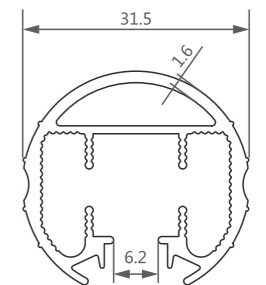

型号/Item No.-11181013
米重/Weight-0.551kg/m

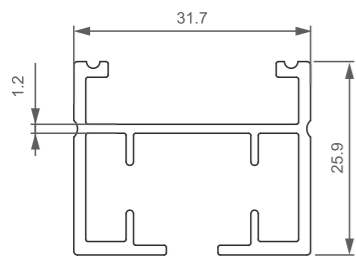

型号/Item No.-1514511
米重/Weight-0.482kg/m

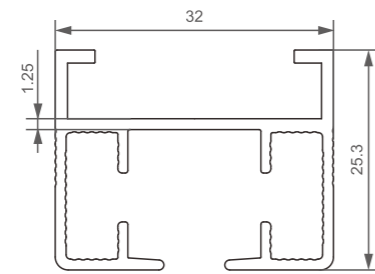

型号/Item No.-13031383
米重/Weight-0.440kg/m

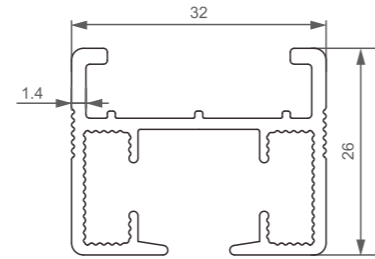

型号/Item No.-1303901
米重/Weight-0.51kg/m

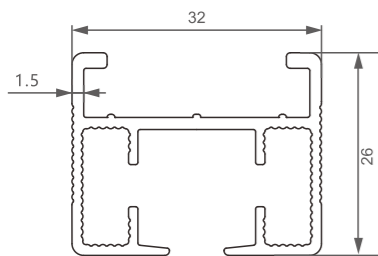

型号/Item No.-1303730
米重/Weight-0.474kg/m

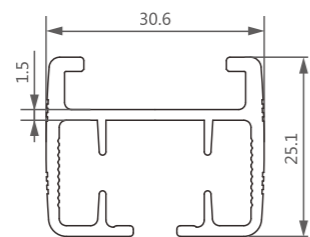

型号/Item No.-1303721
米重/Weight-0.526kg/m

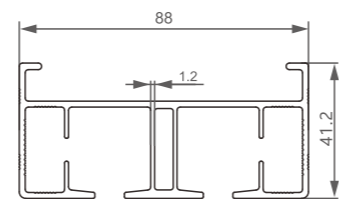

型号/Item No.-19070129
米重/Weight-1.518kg/m

09

户外遮阳系列

Sun Shade Blades



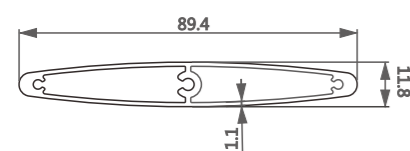

型号/Item No.-4237176
米重/Weight-0.719kg/m

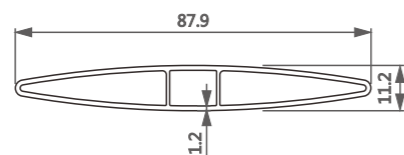

型号/Item No.-7908359
米重/Weight-0.621kg/m

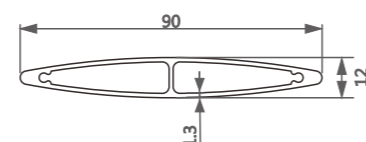

型号/Item No.-1202406
米重/Weight-0.75kg/m

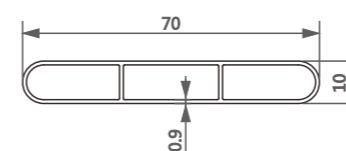

型号/Item No.-4237196
米重/Weight-0.406kg/m

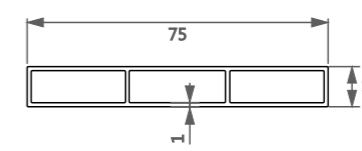

型号/Item No.-4237165
米重/Weight-0.497kg/m

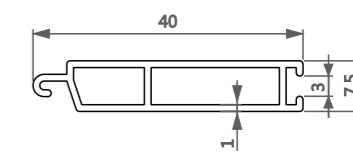

型号/Item No.-4278081
米重/Weight-0.260kg/m

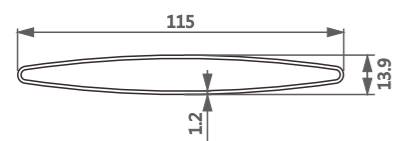

型号/Item No.-7908360
米重/Weight-0.766kg/m

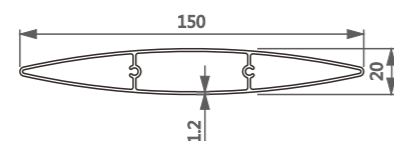

型号/Item No.-4237353
米重/Weight-1.139kg/m

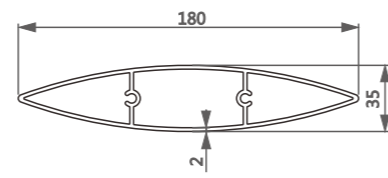

型号/Item No.-4237976
米重/Weight-2.397kg/m

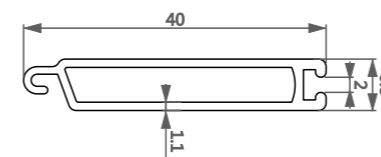

型号/Item No.-4278180
米重/Weight-0.270kg/m

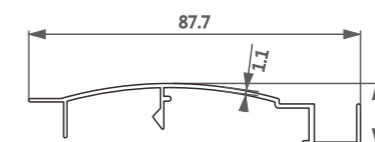

型号/Item No.-19070200
米重/Weight-0.398kg/m

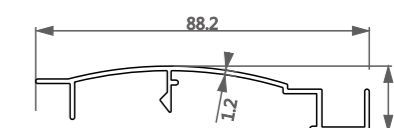

型号/Item No.-19070541
米重/Weight-0.452kg/m

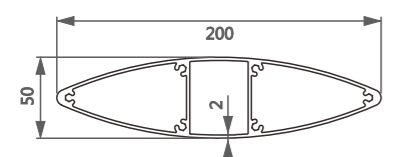

型号/Item No.-42371238
米重/Weight-3.326kg/m

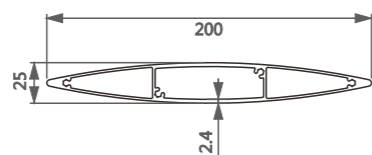

型号/Item No.-42371268
米重/Weight-2.405kg/m

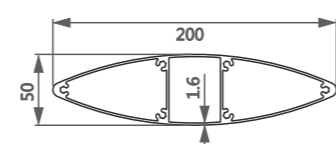

型号/Item No.-42371286
米重/Weight-2.865kg/m

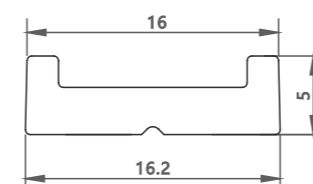

型号/Item No.-19071280
米重/Weight-0.153kg/m

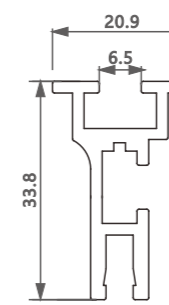

型号/Item No.-19071573
米重/Weight-0.490kg/m

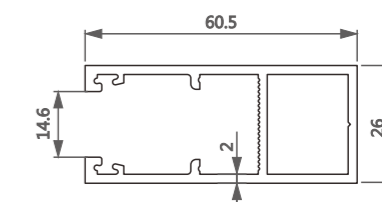

型号/Item No.-4278260
米重/Weight-1.012kg/m

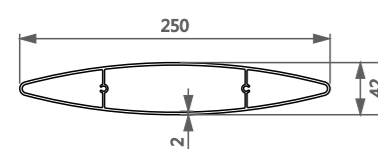

型号/Item No.-4237357
米重/Weight-3.106kg/m

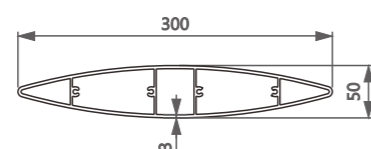

型号/Item No.-42371030
米重/Weight-6.144kg/m

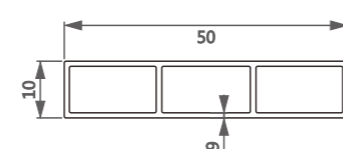

型号/Item No.-4237164
米重/Weight-0.331kg/m

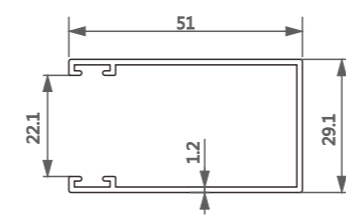

型号/Item No.-0901569
米重/Weight-0.467kg/m

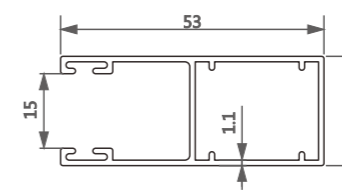

型号/Item No.-4278082
米重/Weight-0.515kg/m

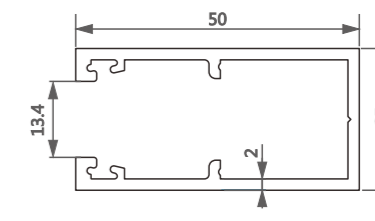

型号/Item No.-4278290
米重/Weight-0.77kg/m

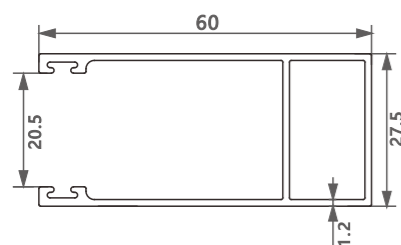

型号/Item No.-79081015-1.2
米重/Weight-0.62kg/m

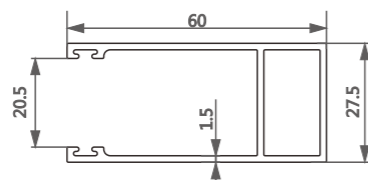

型号/Item No.-79081015-1.5
米重/Weight-0.74kg/m

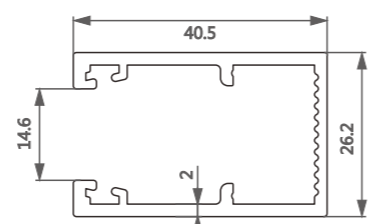

型号/Item No.-7908765
米重/Weight-0.665kg/m

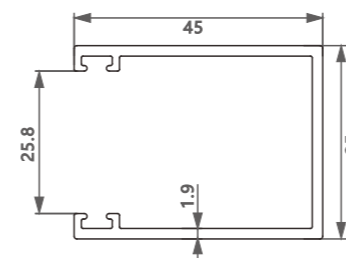

型号/Item No.-79081104
米重/Weight-0.677kg/m

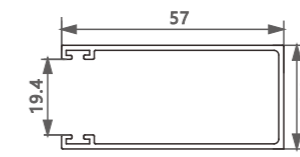

型号/Item No.-79081194
米重/Weight-0.538kg/m

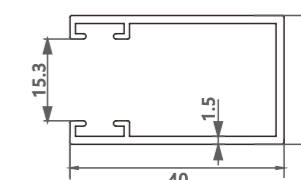

型号/Item No.-0901583
米重/Weight-0.466kg/m

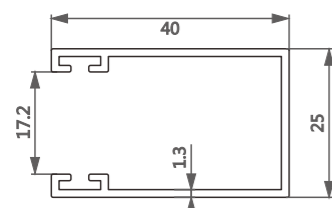

型号/Item No.-0901586
米重/Weight-0.424kg/m

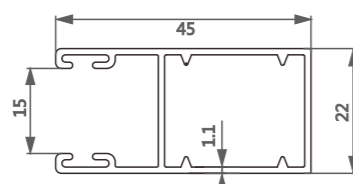

型号/Item No.-79081017
米重/Weight-0.465kg/m

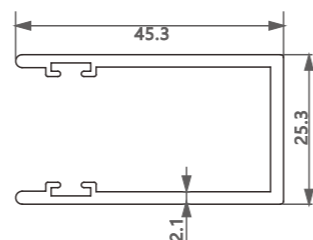

型号/Item No.-0901450
米重/Weight-0.65kg/m

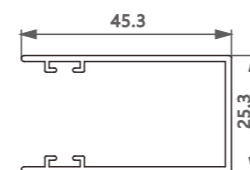

型号/Item No.-0901592
米重/Weight-0.438kg/m

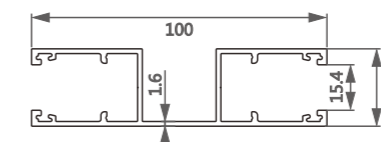

型号/Item No.-19070198
米重/Weight-1.183kg/m

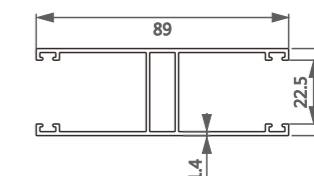

型号/Item No.-4278329
米重/Weight-0.961kg/m

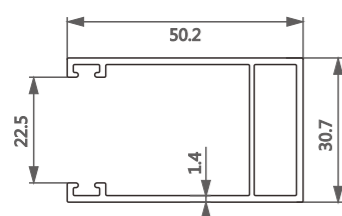

型号/Item No.-4278330
米重/Weight-0.615kg/m

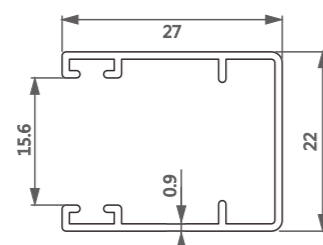

型号/Item No.-4278083
米重/Weight-0.228kg/m

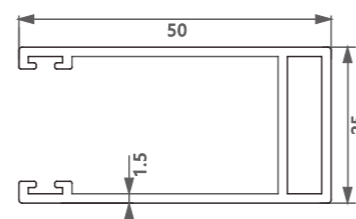

型号/Item No.-79081040
米重/Weight-0.635kg/m

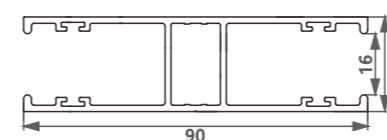

型号/Item No.-79081139
米重/Weight-1.133kg/m

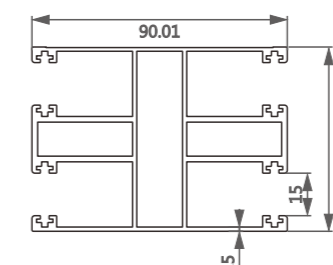

型号/Item No.-0901509
米重/Weight-2.55kg/m

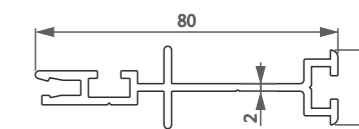

型号/Item No.-7908865
米重/Weight-0.878kg/m

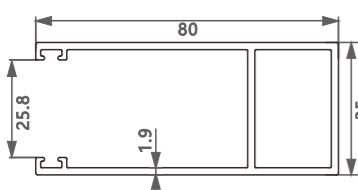

型号/Item No.-79081105
米重/Weight-1.202kg/m

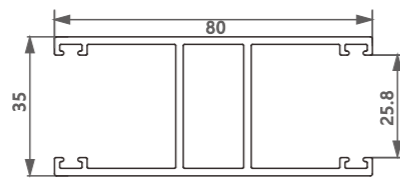

型号/Item No.-79081106
米重/Weight-1.251kg/m

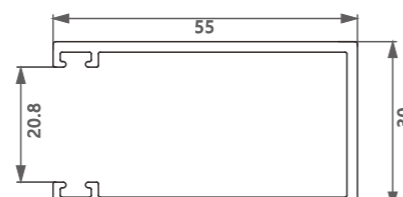

型号/Item No.-79081103
米重/Weight-0.755kg/m

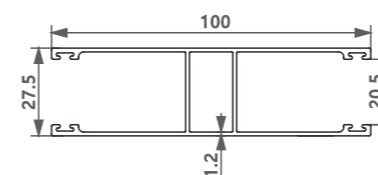

型号/Item No.-79081016-1.2
米重/Weight-0.945kg/m

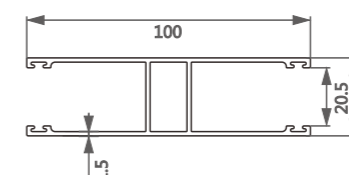

型号/Item No.-79081016-1.5
米重/Weight-1.116kg/m

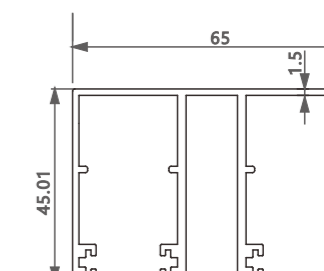

型号/Item No.-0901508
米重/Weight-1.398kg/m

扁条系列 *Flat Bar*

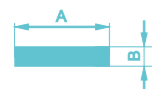

编号 Item No.	长(A)	壁厚(T)	重量(KG/M)	规格S<长(A)*高(H)*壁厚(T)>
9200130	3.8	2.4	0.250	3.8*2.4
926507	8	1.3	0.027	8*1.3
432231	9	2	0.049	9*2
9200257	9	3	0.073	9*3
9200155	9.53	4.18	0.109	9.53*4.18
9200200	9.6	1.2	0.031	9.6*1.2
362033	10	1.5	0.040	10*1.5
9200318	10	1.5	0.039	10*1.5
9200246	10	2	0.052	10*2
9200303	10	2	0.054	10*2
9200340	11.8	1.8	0.056	11.8*1.8
9200339	11.8	2.4	0.074	11.8*2.4
3620109	11.9	1.5	0.048	11.9*1.5
922530	12	1.4	0.046	12*1.4
920010	12	2	0.063	12*2
920011	12	3	0.093	12*3
920099	12	3	0.098	12*3
927641	12.5	1.6	0.054	12.5*1.6
9200238	12.6	3.4	0.114	12.6*3.4
9200239	12.7	3.5	0.114	12.7*3.5
920005	13	3	0.107	13*3
9200249	13	4.3	0.153	13*4.3
9200131	14	2.3	0.087	14*2.3

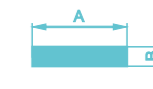

编号 Item No.	长(A)	壁厚(T)	重量(KG/M)	规格S<长(A)*高(H)*壁厚(T)>
920016	14	3	0.109	14*3
920013	14	7	0.267	14*7
920003	15	1	0.040	15*1
9200319	15	1.5	0.060	15*1.5
920004	15	2	0.018	15*2
922144	15	2	0.080	15*2
9200317	15	2.5	0.102	15*2.5
920001	15	3	0.118	15*3
922143	15	3	0.118	15*3
9200137	15	4	0.165	15*4
920012	16	1.5	0.065	16*1.5
9200215	16	3	0.131	16*3
421254	16	6	0.261	16*6
920025	17	4	0.185	17*4
9200240	17.9	2.7	0.132	17.9*2.7
9200241	18	2.8	0.138	18*2.8
9200268	18	3.5	0.165	18*3.5
9200307	18	4	0.203	18*4
9200342	18.8	4.6	0.236	18.8*4.6
463748	19	2	0.103	19*2
463747	19	3	0.150	19*3
920043	19	3	0.155	19*3
421253	19	10	0.515	19*10

扁条系列 *Flat Bar*

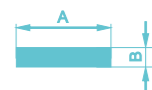

编号 Item No.	长(A)	壁厚(T)	重量(KG/M)	规格S<长(A)*高(H)*壁厚(T)>
9200141	19.1	4	0.208	19.1*4
9200320	20	1.5	0.080	20*1.5
9200136	20	2.5	0.136	20*2.5
920006	20	3	0.164	20*3
920046	20	3	0.159	20*3
9200293	20	3	0.159	20*3
9200218	20	4	0.209	20*4
9200223	20	4	0.218	20*4
9200158	20	6	0.307	20*6
9200276	20	6	0.328	20*6
9200128	20	8	0.433	20*8
9200124	20.3	3	0.166	20.3*3
9200142	21.9	4	0.230	21.9*4
9200316	22	2	0.119	22*2
9200130	23	3	0.186	23*3
920052	24.5	3	0.195	24.5*3
9200321	25	1.5	0.101	25*1.5
920007	25	3	0.205	25*3
920021	25	3	0.199	25*3
9200209	25	4	0.264	25*4
920002	25	5	0.338	25*5
9200157	25	5	0.327	25*5
9200116	25	10	0.682	25*10



编号 Item No.	长(A)	壁厚(T)	重量(KG/M)	规格S<长(A)*高(H)*壁厚(T)>
9200271	25.2	3	0.202	25.2*3
920027	25.2	3.2	0.214	25.2*3.2
9200232	25.2	2.7	0.192	25.2*2.7
9200250	25.4	2	0.139	25.4*2
9200233	25.4	2.8	0.192	25.4*2.8
463749	25.4	3	0.206	25.4*3
9200197	25.5	4.6	0.320	25.5*4.6
9200264	25.5	4.8	0.332	25.5*4.8
9200160	25.5	6.2	0.429	25.5*6.2
920029	26	3	0.212	26*3
9200260	28	1.7	0.130	28*1.7
9200153	28	2	0.153	28*2
9200269	28	2.6	0.199	28*2.6
9200290	30	1	0.082	30*1
9200322	30	1.5	0.121	30*1.5
9200304	30	2	0.164	30*2
9200247	30	3	0.241	30*3
9200292	30	3	0.243	30*3
920026	30	3.7	0.295	30*3.7
9200103	30	4	0.318	30*4
463750	31	3.9	0.329	31*3.9
9200230	31.7	2.7	0.234	31.7*2.7
9200231	31.8	2.8	0.243	31.8*2.8

扁条系列 *Flat Bar*

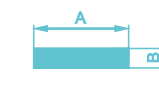
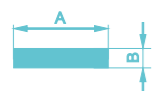

编号 Item No.	长(A)	壁厚(T)	重量(KG/M)	规格S<长(A)*高(H)*壁厚(T)>
9200330	32	2	0.174	32*2
920015	32	3	0.262	32*3
920045	35	1.5	0.142	35*1.5
9200336	35	1.5	0.142	35*1.5
9200329	36	1	0.098	36*1
9200298	37	2	0.201	37*2
9200228	38	2.7	0.288	38*2.7
920014	38	3.8	0.394	38*3.8
9200229	38.1	2.8	0.288	38.1*2.8
9200270	38.5	3.6	0.378	38.5*3.6
9200323	40	1.5	0.162	40*1.5
920008	40	3	0.327	40*3
9200341	40	4	0.427	40*4
9200117	40	8	0.873	40*8
9200115	40	12	1.310	40*12
920028	40.1	3.2	0.344	40.1*3.2
9200272	40.2	3	0.325	40.2*3
9200313	43.65	5.2	0.603	43.65*5.2
9200337	50	1.5	0.207	50*1.5
920009	50	3	0.410	50*3
9200120	50	4.7	0.639	50*4.7
9200203	50	10	1.363	50*10
505008	50	12	1.628	50*12

编号 Item No.	长(A)	壁厚(T)	重量(KG/M)	规格S<长(A)*高(H)*壁厚(T)>
9200147	50	15	2.042	50*15
9200226	50.7	3.08	0.426	50.7*3.08
9200227	50.8	3.18	0.441	50.8*3.18
9200213	55	2	0.300	55*2
9200328	57	5	0.777	57*5
463751	58	2	0.314	58*2
9200338	60	1.5	0.244	60*1.5
9200193	60	14	2.293	60*14
9200214	66	2	0.360	66*2
9200205	74.6	2	0.408	74.6*2
9200315	75	5	1.023	75*5
9200225	80	1.8	0.393	80*1.8
9200301	80	2.5	0.546	80*2.5
920039	80	4.9	1.070	80*4.9
447250	88.9	12.7	3.082	88.9*12.7
9200150	100	4	1.092	100*4
9200325	100	8	2.146	100*8
9200331	100	8	2.182	100*8
9200119	101	4	1.101	101*4
467203	102	4.7	1.309	102*4.7
9200324	120	10	3.217	120*10
92000217	120	12	3.922	120*12
447249	127	9.52	3.300	127*9.52
9200332	139	8	3.033	139*8

扁条系列 *Flat Bar*

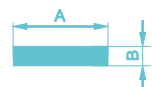

编号 Item No.	长(A)	壁厚(T)	重量(KG/M)	规格S<长(A)*高(H)*壁厚(T)>
920005	13	3	0.107	13*3
920010	12	2	0.063	12*2
920011	12	3	0.093	12*3
9200122	34.8	1.5	0.110	34.8*1.5
9200131	14	2.3	0.087	14*2.3
9200144	20	8	0.437	20*8
9200151	24.1	2.5	0.151	24.1*2.5
9200155	9.53	4.18	0.109	9.53*4.18
9200200	9.6	1.2	0.031	9.6*1.2
9200238	12.6	3.4	0.114	12.6*3.4
9200244	21	4	0.212	21*4
9200246	10	2	0.052	10*2
9200249	13	4.3	0.153	13*4.3
9200257	9	3	0.073	9*3
9200260	28	1.7	0.130	28*1.7
9200273	18	1.8	0.131	18*1.8
9200275	24	2	0.096	24*2
9200277	3.8	2.4	0.025	3.8*2.4
9200278	43.65	5.2	0.525	43.65*5.2
9200288	75	20	3.98	75*20
920029	26	3	0.212	26*3
9200291	20	4	0.305	20*4
9200294	19.9	3.9	0.201	19.9*3.9
9200303	10	2	0.054	10*2



编号 Item No.	长(A)	壁厚(T)	重量(KG/M)	规格S<长(A)*高(H)*壁厚(T)>
9200310	45.54	7	0.717	45.54*7
9200318	10	1.5	0.039	10*1.5
9200325	100	8	2.146	100*8
9200339	11.8	2.4	0.074	11.8*2.4
9200340	11.8	1.8	0.056	11.8*1.8
9200343	149	9.5	2.68	149*9.5
9200344	9	2	0.049	9*2
9200345	20	3	0.164	20*3
9200346	25	2.9	0.198	25*2.9
9200347	25	2.2	0.15	25*2.2
9200348	40	15.5	1.692	40*15.5
9200349	10	2.29	0.054	10*2.29
9200353	30	2.5	0.201	30*2.5
9200354-C	19	2.8	0.145	19*2.8
9200355-C	20.5	3.8	0.2	20.5*3.8
9200356-C	24.7	2.7	0.182	24.7*2.7
9200357	100	10	2.728	100*10
9200358	120	10	3.274	120*10
9200359-C	40	3	0.322	40*3
920036	41	5.5	0.512	41*5.5
9200361-C	16	2.8	0.122	16*2.8
9200362	14	0.2	0.093	14*0.2
9200363	20	2	0.109	20*2



圆管系列 *Round Tube*



编号 Item No.	外直径(Φ)	壁厚(T)	重量(KG/M)	规格S<长(A)*高(H)*壁厚(T)>
6110120	5.6	0.8	0.033	5.6*0.8
6110466	6	0.9	0.39	6*0.9
611026	6	1.05	0.045	6*1.05
6110257	6.4	1	0.046	6.4*1
6110368	6.6	1.1	0.052	6.6*1.1
6110289	6.7	0.6	0.031	6.7*0.6
611084	6.8	0.8	0.041	6.8*0.8
6110461	7	1.5	0.071	7*1.5
6110216	7.1	0.8	0.043	7.1*0.8
6110507	7.5	2.25	0.101	7.5*2.25
6110448	7.6	0.6	0.036	7.6*0.6
611077	8	1	0.060	8*1
6110172	8	1	0.060	8*1
6110295	8	1	0.060	8*1
6110141	8	1.25	0.072	8*1.25
6110475	8	1.5	0.084	8*1.5
611076	8	2	0.103	8*2
6110429	8.1	1.55	0.087	8.1*1.55
6110500	8.2	1.2	0.072	8.2*1.2
6110256	8.3	0.6	0.046	8.3*0.6
6110445	8.4	1.2	0.074	8.4*1.2
611027	8.5	0.5	0.034	8.5*0.5
6110520	9	0.6	0.043	9*0.6
6110472	9	1	0.068	9*1



编号 Item No.	外直径(Φ)	壁厚(T)	重量(KG/M)	规格S<长(A)*高(H)*壁厚(T)>
6110189	9	1.5	0.096	9*1.5
6110308	9	1.6	0.102	9*1.6
6110105	9	1.8	0.111	9*1.8
6110517	9	1.8	0.111	9*1.8
6110518	9.5	0.7	0.052	9.5*0.7
610189	9.5	0.8	0.059	9.5*0.8
6110217	9.5	0.8	0.060	9.5*0.8
6110367	9.53	1.53	0.100	9.53*1.53
6110512	9.6	0.8	0.060	9.6*0.8
6110204	10	0.8	0.063	10*0.8
111394	10	1	0.077	10*1
6110134	10	1	0.077	10*1
6110532	10	1	0.070	10*1
6110142	10	1.2	0.091	10*1.2
610408	10	1.4	0.103	10*1.4
611075	10	1.5	0.109	10*1.5
6110233	10	1.6	0.115	10*1.6
6110170	10	1.8	0.127	10*1.8
6110452	10	3.35	0.191	10*3.35
611045	11	0.8	0.070	11*0.8
6110462	11.2	1.3	0.110	11.2*1.3
6110543	11.2	1.65	0.135	11.2*1.65
6110434	11.3	1.8	0.147	11.3*1.8
6110424	11.5	1	0.090	11.5*1



圆管系列 *Round Tube*



编号 Item No.	外直径(Φ)	壁厚(T)	重量(KG/M)	规格S<长(A)*高(H)*壁厚(T)>
611051	15	2	0.223	15*2
611085	15.1	1.4	0.164	15.1*1.4
6110547	15.1	2	0.225	15.1*2
611033	15.6	0.84	0.106	15.6*0.84
611034	15.6	1.1	0.137	15.6*1.1
6110169	15.8	1.4	0.173	15.8*1.4
6110343	15.88	1.22	0.153	15.88*1.22
611035	15.9	1.4	0.174	15.9*1.4
6110403	16	0.5	0.066	16*0.5
613815	16	0.8	0.104	16*0.8
6110138	16	0.8	0.104	16*0.8
6110348	16	1	0.129	16*1
6110102	16	1.2	0.152	16*1.2
6110212	16	1.5	0.187	16*1.5
611087	16	1.6	0.198	16*1.6
6110118	16	2	0.240	16*2
6110210	16.9	1	0.136	16.9*1
611066	17.5	0.9	0.128	17.5*0.9
613811	17.5	1	0.157	17.5*1
6110123	17.8	0.7	0.101	17.8*0.7
611047	17.8	0.75	0.110	17.8*0.75
6110109	17.8	1	0.144	17.8*1
611054	18	0.45	0.083	18*0.45
611352	18	1	0.146	18*1



编号 Item No.	外直径(Φ)	壁厚(T)	重量(KG/M)	规格S<长(A)*高(H)*壁厚(T)>
6110207	18	1	0.146	18*1
611088	18	2	0.274	18*2
6110322	18	3	0.386	18*3
6110504	18.1	0.5	0.082	18.1*0.5
6110443	18.5	0.8	0.121	18.5*0.8
613805	18.5	6.25	0.652	18.5*6.25
6110436	18.8	0.8	0.124	18.8*0.8
611019	18.9	0.45	0.071	18.9*0.45
6110539	18.9	0.6	0.094	18.9*0.6
4472159	18.9	1.15	0.175	18.9*1.15
6110377	18.95	0.95	0.147	18.95*0.95
611037	19	0.4	0.064	19*0.4
616801	19	1	0.154	19*1
611020	19	1.1	0.169	19*1.1
611068	19	1.2	0.183	19*1.2
611091	19	1.2	0.183	19*1.2
6110260	19	1.22	0.157	19*1.22
611089	19	1.3	0.197	19*1.3
6110168	19	1.4	0.211	19*1.4
6110103	19	1.5	0.225	19*1.5
611021	19	2	0.292	19*2
6110378	19.05	1	0.155	19.05*1
6110328	19.05	1.2	0.184	19.05*1.2
6110342	19.05	1.22	0.187	19.05*1.22



圆管系列 *Round Tube*



编号 Item No.	外直径(Φ)	壁厚(T)	重量(KG/M)	规格S<长(A)*高(H)*壁厚(T)>
6110203	19.05	1.27	0.194	19.05*1.27
613816	20	0.8	0.132	20*0.8
616802	20	1	0.163	20*1
6110481	20	1	0.162	20*1
6110501	20	6	0.720	20*6
611046	20.1	0.75	0.124	20.1*0.75
6110316	20.51	2	0.317	20.51*2
6110122	20.8	0.7	0.119	20.8*0.7
6110119	21	0.8	0.139	21*0.8
6110106	21	1.3	0.220	21*1.3
611065	21	1.4	0.236	21*1.4
6110458	21	2	0.326	21*2
6110471	21	3.75	0.554	21*3.75
6110127	21.2	0.83	0.145	21.2*0.83
4472160	21.6	1.15	0.202	21.6*1.15
6110208	21.8	1	0.178	21.8*1
611025	21.9	0.45	0.083	21.9*0.45
611036	22	0.38	0.070	22*0.38
616803	22	0.8	0.145	22*0.8
6110435	22	0.8	0.145	22*0.8
611041	22	1	0.180	22*1
616804	22	1	0.180	22*1
6110283	22	1	0.180	22*1
611069	22	1.2	0.214	22*1.2



编号 Item No.	外直径(Φ)	壁厚(T)	重量(KG/M)	规格S<长(A)*高(H)*壁厚(T)>
611079	22	1.5	0.264	22*1.5
611080	22	2	0.343	22*2
611022	22.2	0.8	0.147	22.2*0.8
6110137	22.2	1	0.182	22.2*1
6110239	22.2	1.5	0.266	22.2*1.5
6110240	22.23	2	0.347	22.23*2
6110190	22.6	0.7	0.094	22.6*0.7
6110341	22.6	1.2	0.245	22.6*1.2
613817	22.8	0.8	0.151	22.8*0.8
6110540	22.9	0.6	0.115	22.9*0.6
631072	23	2.6	0.415	23*2.6
6110457	23.2	2	0.364	23.2*2
6110284	23.5	0.5	0.099	23.5*0.5
6110236	23.5	1	0.193	23.5*1
6110286	24	0.7	0.140	24*0.7
6110482	24	1	0.197	24*1
6110485	24	2.75	0.501	24*2.75
611073	24	3.25	0.578	24*3.25
6110497	24	3.35	0.593	24*3.35
6110326	24.6	0.6	0.124	24.6*0.6
611023	24.8	1.46	0.292	24.8*1.46
611038	25	0.4	0.084	25*0.4
611096	25	0.7	0.146	25*0.7
6110198	25	0.7	0.146	25*0.7



圆管系列 *Round Tube*



编号 Item No.	外直径(Φ)	壁厚(T)	重量(KG/M)	规格S<长(A)*高(H)*壁厚(T)>
6110523	11.5	4.1	0.260	11.5*4.1
6110366	11.6	0.6	0.060	11.6*0.6
6110125	11.8	0.7	0.066	11.8*0.7
6110529	11.8	0.8	0.075	11.8*0.8
6110164	11.9	0.8	0.076	11.9*0.8
611043	12	0.4	0.040	12*0.4
611042	12	0.6	0.059	12*0.6
6110521	12	0.6	0.059	12*0.6
6110531	12	0.875	0.083	12*0.875
110174	12	1	0.094	12*1
6110444	12	1	0.094	12*1
6110536	12	1	0.094	12*1
6110438	12	1.3	0.119	12*1.3
6110226	12	1.5	0.145	12*1.5
6110530	12	1.6	0.146	12*1.6
6110446	12	1.85	0.160	12*1.85
6110179	12.3	0.9	0.102	12.3*0.9
6110522	12.4	0.8	0.091	12.4*0.8
6110513	12.9	1.4	0.138	12.9*1.4
6110265	13	0.8	0.095	13*0.8
6110324	13	0.8	0.084	13*0.8
611086	13	1.2	0.121	13*1.2
6110101	13	1.2	0.121	13*1.2
611388	13	1.5	0.147	13*1.5



编号 Item No.	外直径(Φ)	壁厚(T)	重量(KG/M)	规格S<长(A)*高(H)*壁厚(T)>
6110104	13	2	0.189	13*2
6110527	13.6	0.8	0.088	13.6*0.8
6110542	13.7	0.9	0.099	13.7*0.9
6110505	14	1	0.108	14*1
6110487	14	1	0.111	14*1
6110468	14	1.2	0.131	14*1.2
6110261	14	1.7	0.179	14*1.7
6110454	14	2.4	0.239	14*2.4
6110510	14.1	0.65	0.074	14.1*0.65
6110392	14.2	1	0.113	14.2*1
611031	14.3	0.8	0.093	14.3*0.8
6110506	14.3	0.9	0.103	14.3*0.9
6110503	14.3	1.55	0.169	14.3*1.55
6110276	14.4	1.05	0.120	14.4*1.05
6110419	14.5	1.5	0.167	14.5*1.5
611032	14.7	0.8	0.095	14.7*0.8
6110124	14.8	0.7	0.084	14.8*0.7
6110541	14.8	1	0.118	14.8*1
6110225	14.8	1.2	0.140	14.8*1.2
6110538	14.9	0.7	0.085	14.9*0.7
6110389	15	1	0.120	15*1
6110545	15	1	0.120	15*1
611095	15	1.3	0.153	15*1.3
6110410	15	1.5	0.174	15*1.5



圆管系列 *Round Tube*



编号 Item No.	外直径(Φ)	壁厚(T)	重量(KG/M)	规格S<长(A)*高(H)*壁厚(T)>
616814	30	1.8	0.435	30*1.8
616815	30	2	0.480	30*2
6110221	30	2	0.480	30*2
6110398	30	3	0.695	30*3
6110262	31.7	0.8	0.212	31.7*0.8
6110373	31.7	1.05	0.276	31.7*1.05
6110494	31.75	0.7	0.186	31.75*0.7
6110516	31.76	1.25	0.327	31.76*1.25
611050	31.8	0.8	0.213	31.8*0.8
611058	31.8	0.9	0.273	31.8*0.9
6110374	31.8	1.1	0.290	31.8*1.1
6110110	32	1	0.317	32*1
616816	32	1.2	0.266	32*1.2
616817	32	1.5	0.392	32*1.5
6110528	32	1.6	0.417	32*1.6
616818	32	1.8	0.466	32*1.8
616819	32	2	0.515	32*2
6110544	32	6.5	1.422	32*6.5
6110467	32.5	2.1	0.547	32.5*2.1
6110492	34	5.5	1.344	34*5.5
611053	34.9	0.9	0.262	34.9*0.9
611018	35	1	0.292	35*1
6110220	35	2	0.566	35*2
6110152	35.1	0.9	0.264	35.1*0.9



编号 Item No.	外直径(Φ)	壁厚(T)	重量(KG/M)	规格S<长(A)*高(H)*壁厚(T)>
610328	37.6	0.8	0.251	37.6*0.8
6110345	38	1	0.317	38*1
6110371	38	1.15	0.363	38*1.15
6110340	38	1.2	0.379	38*1.2
6110157	38	1.3	0.409	38*1.3
613757	38	2	0.618	38*2
6110264	38	3	0.901	38*3
6110372	38.1	1.2	0.379	38.1*1.2
6110320	39	3.5	1.066	39*3.5
6110483	40	1.5	0.495	40*1.5
6110423	40.2	2.65	0.853	40.2*2.65
610145	40.4	2	0.654	40.4*2
6110294	40.7	1.6	0.524	40.7*1.6
6110437	40.8	1.9	0.633	40.8*1.9
6110478	41	6.75	1.982	41*6.75
6110480	41	9.5	2.566	41*9.5
6110495	42	7.25	2.160	42*7.25
6110470	42	7.5	2.219	42*7.5
6110515	45	1.5	0.560	45*1.5
610320	45	1.75	0.649	45*1.75
610180	46.9	2.15	0.820	46.9*2.15
6110479	47	6.75	2.330	47*6.75
6110205	48	8.5	2.880	48*8.5
6110291	49	2	0.806	49*2



圆管系列 *Round Tube*



编号 Item No.	外直径(Φ)	壁厚(T)	重量(KG/M)	规格S<长(A)*高(H)*壁厚(T)>
6110460	25	0.7	0.146	25*0.7
6110107	25	0.8	0.166	25*0.8
611097	25	0.9	0.186	25*0.9
6110279	25	1	0.206	25*1
616805	25	1.2	0.245	25*1.2
6110496	25	1.2	0.244	25*1.2
611029	25	1.3	0.264	25*1.3
611030	25	1.4	0.283	25*1.4
616806	25	1.5	0.302	25*1.5
616807	25	1.8	0.358	25*1.8
616808	25	2	0.395	25*2
6110222	25	6	0.978	25*6
6110275	25.2	0.6	0.127	25.2*0.6
6110375	25.3	1.05	0.218	25.3*1.05
6110206	25.3	1.5	0.306	25.3*1.5
611024	25.4	0.8	0.169	25.4*0.8
611048	25.4	0.97	0.180	25.4*0.97
6110376	25.4	1.1	0.230	25.4*1.1
6110241	25.4	1.5	0.307	25.4*1.5
6110251	25.5	0.7	0.147	25.5*0.7
6110180	25.5	0.75	0.159	25.5*0.75
6110211	25.6	1	0.211	25.6*1
6110282	26	1.25	0.265	26*1.25
6110490	26	3.5	0.675	26*3.5



编号 Item No.	外直径(Φ)	壁厚(T)	重量(KG/M)	规格S<长(A)*高(H)*壁厚(T)>
611060	26.4	0.9	0.197	26.4*0.9
6110218	26.7	1	0.220	26.7*1
6110184	27	1.2	0.265	27*1.2
6110453	27.6	0.8	0.184	27.6*0.8
6110182	28	0.7	0.164	28*0.7
6110280	28	0.7	0.231	28*0.7
6110139	28	0.8	0.187	28*0.8
616812	28	1	0.249	28*1
6110546	28	1.1	0.254	28*1.1
611070	28	1.2	0.276	28*1.2
6110281	28	1.4	0.319	28*1.4
611028	28	1.5	0.341	28*1.5
616809	28	1.5	0.341	28*1.5
616810	28	1.8	0.404	28*1.8
616811	28	2	0.446	28*2
6110232	28	2.75	0.596	28*2.75
611049	28.5	0.8	0.190	28.5*0.8
613806	28.5	5.65	1.100	28.5*5.65
6110111	29	1	0.240	29*1
6110469-1.3	29	1.3	0.308	29*1.3
6110469-1.6	29	1.6	0.375	29*1.6
6110486	29	2.25	0.516	29*2.25
6110491	29	5	1.029	29*5
616813	30	1.5	0.367	30*1.5



方管系列 *Square Tube*

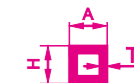

编号 Item No.	长 (A)	高 (H)	壁厚(T)	重量(KG/M)	规格S<长(A)*高(H)*壁厚(T)>
940059	6.3	6.3	1.15	0.061	6.3*6.3*1.15
9400437	10	10	1	0.098	10*10*1
9400463	10	10	1	0.098	10*10*1
9400175	11.5	11.5	1	0.135	11.5*11.5*1
9400191	12.5	12.5	0.8	0.088	12.5*12.5*0.8
9400270	12	12	1.5	0.169	12*12*1.5
9400401	12.15	12.15	1.3	0.151	12.15*12.15*1.3
9400308	12.6	12.6	1.25	0.154	12.6*12.6*1.25
9400145	12.6	12.6	1.35	0.165	12.6*12.6*1.35
646701	12.8	12.8	0.65	0.086	12.8*12.8*0.65
643814	12.8	12.8	0.7	0.087	12.8*12.8*0.7
940021	13	13	1.6	0.199	13*13*1.6
642102	14.7	14.7	0.8	0.118	14.7*14.7*0.8
9400231	15	15	0.8	0.123	15*15*0.8
940012	15	15	1	0.152	15*15*1
940067	15	15	1.3	0.194	15*15*1.3
9400304	15	15	1.5	0.221	15*15*1.5
9400278	15	15	2	0.284	15*15*2
9400304	15	15	1.5	0.221	15*15*1.5
9400211	15.49	15.49	1.14	0.176	15.49*15.49*1.14
9400211	15.5	15.5	1.14	0.176	15.5*15.5*1.14
940027	15.9	15.9	1	0.162	15.9*15.9*1
940027	15.9	15.9	1	0.164	15.9*15.9*1
9400424	15.9	15.9	0.7	0.112	15.9*15.9*0.7

编号 Item No.	长 (A)	高 (H)	壁厚(T)	重量(KG/M)	规格S<长(A)*高(H)*壁厚(T)>
9400153	16	16	3	0.426	16*16*3
9400432	16	16	1	0.154	16*16*1
940075	16	16	1.2	0.188	16*16*1.2
940095	16	16	1.2	0.194	16*16*1.2
9400251	16	16	1.2	0.194	16*16*1.2
646702	16.2	16.2	0.7	0.118	16.2*16.2*0.7
643810	16.2	16.2	0.8	0.128	16.2*16.2*0.8
9400111	16.4	16.4	0.6	0.099	16.4*16.4*0.6
9400386	17	17	1.3	0.217	17*17*1.3
9400307	18.9	18.9	1.3	0.248	18.9*18.9*1.3
9400176	18.9	18.9	0.95	0.208	18.9*18.9*0.95
9400324	18.95	18.95	1.15	0.231	18.95*18.95*1.15
9400442	19	19	0.7	0.139	19*19*0.7
9400431	19	19	1	0.187	19*19*1
940049	19	19	1.3	0.251	19*19*1.3
9400144	19	19	1.35	0.258	19*19*1.35
940074	19	19	1.5	0.278	19*19*1.5
940060	19	19	1.6	0.304	19*19*1.6
9400325	19.05	19.05	1.2	0.231	19.05*19.05*1.2
643809	20	20	0.8	0.159	20*20*0.8
9400430	20	20	1	0.198	20*20*1
940025	20	20	1.2	0.249	20*20*1.2
940022	20	20	1.6	0.322	20*20*1.6
9400185	20	20	2	0.393	20*20*2



方管系列 *Square Tube*



编号 Item No.	长 (A)	高 (H)	壁厚(T)	重量(KG /M)	规格<长(A)*高(H)*壁厚 (T) >
9400180	20	20	1.4	0.304	20*20*1.4
9400305	21	21	1.2	0.259	21*21*1.2
646703	20.2	20.2	0.7	0.149	20.2*20.2*0.7
9400354	20.3	20.3	1.15	0.236	20.3*20.3*1.15
643808	23.4	23.4	0.8	0.187	23.4*23.4*0.8
940082	24.8	24.8	0.9	0.235	24.8*24.8*0.9
642125	25	25	0.7	0.181	25*25*0.7
940084	25	25	1	0.262	25*25*1
9400429	25	25	1	0.252	25*25*1
940026	25	25	1.2	0.311	25*25*1.2
9400402	25	25	1.5	0.368	25*25*1.5
642146	25	25	1.6	0.409	25*25*1.6
940023	25	25	1.6	0.409	25*25*1.6
9400130	25	25	2	0.502	25*25*2
9400326	25.3	25.3	1.05	0.289	25.3*25.3*1.05
9400327	25.4	25.4	1.1	0.289	25.4*25.4*1.1
9400287	25.4	25.4	1.2	0.317	25.4*25.4*1.2
9400156	26.88	26.88	1.2	0.326	26.88*26.88*1.2
9400396	27.5	27.5	1.25	0.358	27.5*27.5*1.25
9400113	28	28	0.8	0.238	28*28*0.8
940058	30	30	1.9	0.583	30*30*1.9
9400277	30	30	2	0.612	30*30*2
9400444	30	30	2	0.592	30*30*2
9400129	30	30	3	0.885	30*30*3



编号 Item No.	长 (A)	高 (H)	壁厚(T)	重量(KG /M)	规格<长(A)*高(H)*壁厚 (T) >
9400241	30	30	1.2	0.355	30*30*1.2
9400328	31.65	31.65	1.25	0.428	31.65*31.65*1.25
9400329	31.75	31.75	1.3	0.428	31.75*31.75*1.3
9400433	32	32	2	0.655	32*32*2
940056	35	35	1.9	0.687	35*35*1.9
9400105	38	38	1	0.397	38*38*1
9400330	38	38	1.15	0.478	38*38*1.15
9400184	38	38	2	0.786	38*38*2
9400154	38	38	6	2.092	38*38*6
9400331	38.1	38.1	1.2	0.478	38.1*38.1*1.2
9400210	38.1	38.1	3.18	1.211	38.1*38.1*3.18
9400414	39.5	39.5	2	0.769	39.5*39.5*2
940015	40	40	1.5	0.790	40*40*1.5
9400464	40	40	1	0.417	40*40*1
9400181	40	40	1.3	0.549	40*40*1.3
9400458	40	40	1.5	0.625	40*40*1.5
940015	40	40	1.9	0.790	40*40*1.9
940077	40	40	2	0.818	40*40*2
9400271	40	40	2	0.823	40*40*2
9400128	40	40	3	1.210	40*40*3
9400445	40.2	40.2	3	1.218	40.2*40.2*3
940094	41.38	41.38	3.1	1.296	41.38*41.38*3.1
9400134	43.31	43.31	2.41	1.055	43.31*43.31*2.41
9400332	44.35	44.35	1.15	0.561	44.35*44.35*1.15



方管系列 *Square Tube*



编号 Item No.	长 (A)	高 (H)	壁厚(T)	重量(KG/M)	规格S<长(A)*高(H)*壁厚(T)>
9400333	44.45	44.35	1.2	0.560	44.35*44.35*1.2
9400207	45	45	2	0.321	45*45*2
9400427	45	45	1.2	0.563	45*45*1.2
9400292	50	50	1.4	0.743	50*50*1.4
940047	50	50	1.6	0.846	50*50*1.6
9400206	50	50	2	1.039	50*50*2
9400273	50	50	3	1.553	50*50*3
9400461	50	50	5	2.457	50*50*5
9400334	50.7	50.7	1.15	0.643	50.7*50.7*1.15
9400335	50.8	50.8	1.2	0.643	50.8*50.8*1.2
9400242	50.8	50.8	1.52	0.804	50.8*50.8*1.52
940092	50.8	50.8	1.53	0.820	50.8*50.8*1.53
940076	50.8	50.8	2	1.045	50.8*50.8*2
940093	50.8	50.8	3.1	1.615	50.8*50.8*3.1
9400118	60	60	2	1.267	60*60*2
9400229	60	60	2.9	1.808	60*60*2.9
9400213	63.5	63.5	3.18	1.973	63.5*63.5*3.18
940085	65	65	1.2	0.823	65*65*1.2
9400115	75	75	2	1.592	75*75*2
9400200	75	75	3	2.358	75*75*3
9400440	76	76	6	4.586	76*76*6
9400336	76.1	76.1	1.55	1.289	76.1*76.1*1.55
9400337	76.2	76.2	1.6	1.289	76.2*76.2*1.6
9400135	84.58	84.58	4.06	3.515	84.58*84.58*4.06

编号 Item No.	长 (A)	高 (H)	壁厚(T)	重量(KG/M)	规格S<长(A)*高(H)*壁厚(T)>
9400389	88.9	88.9	2.159	1.990	88.9*88.9*2.159
9400350	88.9	88.9	2.5	2.230	88.9*88.9*2.5
9400321	88.9	88.9	3	2.746	88.9*88.9*3
9400361	100	100	2	2.140	100*100*2
9400280	100	100	6	5.096	100*100*6
9400338	101.5	101.5	1.95	2.154	101.5*101.5*1.95
9400339	101.6	101.6	2	2.154	101.6*101.6*2
9400281	120	120	8	7.761	120*120*8



方管系列 *Square Tube*

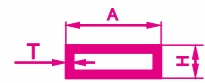

编号 Item No.	长 (A)	高 (H)	壁厚 (T)	重量 (KG/M)	规格S<长(A)*高(H)*壁厚(T)>
9400453	10.6	7.6	0.8	0.065	10.6*7.6*0.8
9400452	10.6	9	0.8	0.078	10.6*9*0.8
9400441	12	10	1	0.109	12*10*1
9400172	12.6	5.5	0.8	0.071	12.6*5.5*0.8
9400460	14.2	11.6	1.5	0.186	14.2*11.6*1.5
642142	16	13	0.9	0.131	16*13*0.9
642127	17.5	9.8	0.7	0.095	17.5*9.8*0.7
9400436	20	10	1	0.152	20*10*1
9400426	20	14	1	0.174	20*14*1
9400143	25	10	1.2	0.214	25*10*1.2
9400409	25	15	0.6	0.125	25*15*0.6
940070	25	15	1.3	0.260	25*15*1.3
9400246	25.3	12.6	1.15	0.224	25.3*12.6*1.15
9400249	25.4	12.7	1.27	0.247	25.4*12.7*1.27
9400371	28	18	1	0.238	28*18*1
9400410	30	15	0.6	0.142	30*15*0.6
940069	30	15	1.3	0.296	30*15*1.3
9400265	30	20	1.5	0.385	30*20*1.5
9400131	30	20	2	0.520	30*20*2
9400240	30	25	1.5	0.426	30*25*1.5
9400112	30.2	15.2	1.3	0.303	30.2*15.2*1.3
940087	32	10	0.9	0.198	32*10*0.9
9400274	35	20	2	0.550	35*20*2
9400428	38	25	1	0.323	38*25*1

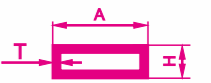

编号 Item No.	长 (A)	高 (H)	壁厚 (T)	重量 (KG/M)	规格S<长(A)*高(H)*壁厚(T)>
9400182	38	25	1.5	0.419	38*25*1.5
940078	38	25	2	0.626	38*25*2
9400340	38	25.3	1.15	0.396	38*25.3*1.15
9400341	38.1	25.4	1.2	0.396	38.1*25.4*1.2
9400288	40	20	1.2	0.377	40*20*1.2
9400266	40	20	1.5	0.467	40*20*1.5
9400465	40	20	1.5	0.462	40*20*1.5
9400272	40	27	3	0.992	40*27*3
9400140	40	30	1.2	0.443	40*30*1.2
9400306	40	32	2	0.743	40*32*2
9400466	45	25	1.5	0.544	45*25*1.5
940088	50	10	0.6	0.193	50*10*0.6
9400462	50	20	1.5	0.549	50*20*1.5
940089	50	24	1	0.391	50*24*1
9400261	50	25	3	1.130	50*25*2.2
9400289	50	30	1.2	0.508	50*30*1.2
9400467	50	30	1.5	0.626	50*30*1.5
940017	50	30	1.8	0.751	50*30*1.8
9400434	50	40	3	1.375	50*40*3
9400194	50.7	25.3	1.15	0.478	50.7*25.3*1.15
9400344	50.7	38	1.15	0.561	50.7*38*1.15
9400189	50.8	25.4	1.2	0.478	50.8*25.4*1.2
9400296	50.8	38.1	1.2	0.567	50.8*38.1*1.2
9400345	50.8	38.1	1.2	0.561	50.8*38.1*1.2



方管系列 *Square Tube*

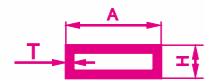

编号 Item No.	长 (A)	高 (H)	壁厚(T)	重量(KG/M)	规格S<长(A)*高(H)*壁厚(T)>
9400265	30	20	1.5	0.385	30*20*1.5
9400290	46.8	11.8	1.2	0.415	46.8*11.8*1.2
9400290-C	46.8	11.8	1.05	0.364	46.8*11.8*1.05
9400299	56.5	15.5	1.5	0.644	56.5*15.5*1.5
9400322	63.9	12.9	0.95	0.393	63.9*12.9*0.95
9400323	64	13	1	0.393	64*13*1
9400365	60	15	3	1.59	60*15*3
9400381	39	6.8	0.8	0.19	39*6.8*0.8
9400391	125	10.5	1.2	0.905	125*10.5*1.2
9400410	30	15	0.7	0.165	30*15*0.7
9400415	65	10	0.8	0.339	65*10*0.8
9400416	90	10	0.8	0.448	90*10*0.8
9400418	51	9	2.5	0.872	51*9*2.5
9400423	20.8	19	0.8	0.172	20.8*19*0.8
9400454	65.1	16.1	1.2	0.613	65.1*16.1*1.2
9400455	50	10	1.2	0.403	50*10*1.2
9400476-C	79.8	49.8	2.9	1.952	79.8*49.8*2.9
9400481	65	16	1.4	0.583	65*16*1.4
9400482	70	40	1.5	0.861	70*40*1.5
9400484-C	85.86	11.86	0.93	0.486	85.86*11.86*0.93
9400485-C	24.8	17.8	1.1	0.243	24.8*17.8*1.1
9400488	75	50	2	1.307	75*50*2
9400489	50	15	1.5	0.508	50*15*1.5
9400490	50	20	1.2	0.442	50*20*1.2

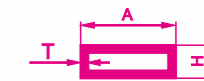

编号 Item No.	长 (A)	高 (H)	壁厚(T)	重量(KG/M)	规格S<长(A)*高(H)*壁厚(T)>
9400351	51	30	3	1.230	51*30*3
9400392	53	30	1.3	0.542	53*30*1.3
9400408	53.3	9.5	0.65	0.22	53.3*9.5*0.65
9400468	55	35	1.5	0.707	55*35*1.5
9400276	57	15	3	1.079	57*15*3
9400419	58	12	0.8	0.297	58*12*0.8
9400447	58.5	29	1.2	0.557	58.5*29*1.2
9400471	59.6	35.1	1.55	0.778	59.6*35.1*1.55
9400235	60	15	3	1.128	60*15*3
9400443	60	30	2	0.939	60*30*2
9400162	60	30	3.5	1.586	60*30*3.5
9400469	60	40	1.5	0.789	60*40*1.5
9400456	68.25	45.25	1.725	1.034	68.25*45.25*1.725
9400385	70	15.2	1	0.454	70*15.2*1
9400163	74	26	1.5	0.794	74*26*1.5
9400446	75	42	1.5	0.925	75*42*1.5
9400342	76.1	25.3	1.25	0.695	76.1*25.3*1.25
9400192	76.1	44.35	1.35	0.891	76.1*44.35*1.35
9400343	76.2	25.4	1.3	0.695	76.2*25.4*1.3
9400417	76.2	25.4	1.4	0.755	76.2*25.4*1.4
9400187	76.2	44.45	1.4	0.891	76.2*44.45*1.4
9400132	76.2	50.8	2	1.341	76.2*50.8*2
940014	80	40	1.9	1.205	80*40*1.9
940002	94	20	2	1.164	94*20*2



方管系列 *Square Tube*

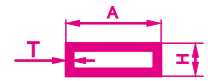

编号 Item No.	长 (A)	高 (H)	壁厚 (T)	重量 (KG/M)	规格S<长(A)*高(H)*壁厚(T)>
9400383	100	3	1.5	1.040	100*30*1.5
9400472	100	40	1.5	1.122	100*40*1.5
9400459	100	40	1.7	1.272	100*40*1.7
940013	100	50	1.9	1.517	100*50*1.9
9400204	100	50	2	1.585	100*50*2
940048	100	50	3	2.359	100*50*3
9400275	100	50	6	4.514	100*50*6
9400245	101.5	25.3	1.25	0.848	101.5*25.3*1.25
9400195	101.5	44.35	1.35	1.044	101.5*44.35*1.35
9400193	101.5	50.7	1.95	1.562	101.5*50.7*1.95
9400291	101.6	25.4	1.2	0.816	101.6*25.4*1.2
9400420	101.6	25.4	2	1.343	101.6*25.4*2
9400190	101.6	44.45	1.4	1.088	101.6*44.45*1.4
9400188	101.6	50.8	2	1.603	101.6*50.8*2
9400228	101.8	32	2.3	1.620	101.8*32*2.3
9400319	115	20	1	0.726	115*20*1
9400260	120	50	2.2	1.990	120*50*2.2
940001	124	20	2	1.491	124*20*2
9400382	160	60	2	2.360	160*60*2
9400131	30	20	2	0.502	30*20*2
940013-C	100	50	1.9	1.517	100*50*1.9
940014-C	80	40	1.9	1.205	80*40*1.9
9400212	25.4	15.9	1.14	0.221	25.4*15.9*1.14
9400237	65	16.1	1.2	0.532	65*16.1*1.2

角铝系列 *L Shape Profile*

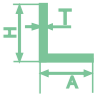

编号 Item No.	长 (A)	高 (H)	壁厚 (T)	重量 (KG/M)	规格S<长(A)*高(H)*壁厚(T)>
930021	9.5	9.5	1	0.049	9.5*9.5*1
9300298	10	10	1	0.051	10*10*1
9300195	12.6	12.6	0.9	0.066	12.6*12.6*0.9
9300196	12.7	12.7	1	0.066	12.7*12.7*1
930039	13	13	1.4	0.094	13*13*1.4
930002	13	13	3	0.188	13*13*3
9300134	15	15	1	0.079	15*15*1
9300245	15	15	1.5	0.117	15*15*1.5
9300135	20	20	1	0.106	20*20*1
9300212	20	20	1.3	0.137	20*20*1.3
930040	20	20	2	0.207	20*20*2
9300194	20	20	2.6	0.262	20*20*2.6
930003	20	20	3	0.302	20*20*3
930011	22	22	2	0.225	22*22*2
9300113	25	25	1	0.134	25*25*1
930012	25	25	1.4	0.186	25*25*1.4
930004	25	25	3	0.384	25*25*3
9300191	25.3	25.3	2.7	0.363	25.3*25.3*2.7
9300192	25.4	25.4	2.8	0.363	25.4*25.4*2.8
930030	26	26	1.8	0.243	26*26*1.8
9300137	30	30	1.2	0.193	30*30*1.2
9300299	30	30	1.3	0.207	30*30*1.3
9300127	30	30	2.8	0.437	30*30*2.8
9300190	31.2	31.2	4.2	0.661	31.2*31.2*4.2



角铝系列 *L Shape Profile*

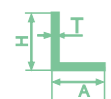

编号 Item No.	长 (A)	高 (H)	壁厚(T)	重量(KG/M)	规格S<长(A)*高(H)*壁厚(T)>
9300205	31.65	31.65	2.7	0.459	31.65*31.65*2.7
9300206	31.75	31.75	2.8	0.459	31.75*31.75*2.8
930013	32	32	1.6	0.273	32*32*1.6
930005	32	32	3	0.499	32*32*3
9300300	35	35	1.3	0.242	35*35*1.3
9300202	38	38	5	0.962	38*38*5
9300182	38.1	38.1	2.7	0.561	38.1*38.1*2.7
9300186	38.1	38.1	4.2	0.820	38.1*38.1*4.2
9300291	40	40	1	0.201	40*40*1
9300301	40	40	1.3	0.278	40*40*1.3
930014	40	40	1.5	0.322	40*40*1.5
9300316	40	40	1.6	0.342	40*40*1.6
930006	40	40	3	0.630	40*40*3
9300128	40	40	3.8	0.790	40*40*3.8
9300233	40	40	4	0.823	40*40*4
930015	50	50	1.5	0.403	50*50*1.5
930007	50	50	3	0.794	50*50*3
9300199	50.7	50.7	2.7	0.747	50.7*50.7*2.7
9300200	50.8	50.8	2.8	0.747	50.8*50.8*2.8
9300188	50.8	50.8	4.2	1.108	50.8*50.8*4.2
9300276	60	60	2.8	0.896	60*60*2.8
9300315	76	76	6	2.391	76*76*6
9300290	125	125	6	3.990	125*125*6



编号 Item No.	长 (A)	高 (H)	壁厚(T)	重量(KG/M)	规格S<长(A)*高(H)*壁厚(T)>
9300123	12	10	1.5	0.083	12*10*1.5
9300124	13	11	2	0.118	13*11*2
9300302	15	10	1	0.065	15*10*1
9300303	20	10	1	0.078	20*10*1
9300162	20	10	2	0.153	20*10*2
9300319	20	12	1.6	0.132	20*12*1.6
930016	20	13	1.4	0.121	20*13*1.4
9300305	20	15	1	0.092	20*15*1
9300114	23	10	1.4	0.121	23*10*1.4
9300251	24.9	19.9	1.5	0.188	24.9*19.9*1.5
9300304	25	10	1	0.092	25*10*1
9300170	25	10	2	0.180	25*10*2
9300321	25	12	3	0.175	25*12*3
930017	22	13	1.5	0.150	25*13*1.5
9300306	25	15	1	0.106	25*15*1
9300169	25	15	2	0.207	25*15*2
9300320	25	17	3	0.216	25*17*3
9300174	25	20	0.9	0.110	25*20*0.9
9300271	25	20	1	0.120	25*20*1
930018	25	20	1.5	0.177	25*20*1.5
9300318	25	20	1.6	0.189	25*20*1.6
9300282	25	20	3	0.344	25*20*3
9300307	30	15	1	0.119	30*15*1
9300244	30	18	1.2	0.153	30*18*1.2



角铝系列 *L Shape Profile*

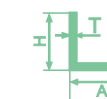

编号 Item No.	长 (A)	高 (H)	壁厚 (T)	重量 (KG / M)	规格 S<长 (A)*高 (H)*壁厚 (T)>
930022	30	19.5	2.6	0.333	30*19.5*2.6
9300308	30	20	1.3	0.171	30*20*1.3
9300181	30	20	2	0.262	30*20*2
9300184	30.4	20.4	1.8	0.239	30.4*20.4*1.8
930044	31.6	22	1.5	0.213	31.6*22*1.5
9300249	31.9	19.9	1.5	0.219	31.9*19.9*1.5
9300149	35	30	5	0.816	35*30*5
930042	38	15	3	0.409	38*15*3
9300204	38.1	19.05	2.8	0.417	38.1*19.05*2.8
930043	38.1	22.2	1.6	0.256	38.1*22.2*1.6
930041	38.1	22.23	3.2	0.498	38.1*22.23*3.2
9300252	39.9	19.9	1.5	0.253	39.9*19.9*1.5
9300309	40	10	1	0.133	40*10*1
9300310	40	15	1.3	0.189	40*15*1.3
9300317	40	20	1.6	0.254	40*20*1.6
9300111	40	20	2	0.316	40*20*2
9300163	40	20	2	0.317	40*20*2
930019	40	25	1.5	0.260	40*25*1.5
9300283	40	25	2.5	0.427	40*25*2.5
9300227	40	25	4.5	0.743	40*25*4.5
9300250	40	15	1.2	0.184	43*15*1.2
9300253	49.9	24.9	1.5	0.318	49.9*24.9*1.5
9300236	50	20	3	0.501	50*20*3
930020	50	25	1.5	0.301	50*25*1.5

编号 Item No.	长 (A)	高 (H)	壁厚 (T)	重量 (KG / M)	规格 S<长 (A)*高 (H)*壁厚 (T)>
9300256	55.1	20.1	1.9	0.378	55.1*20.1*1.9
930031	56	25	4	0.822	56*25*4
9300126	60	20	3	0.491	60*20*3
9300234	60	40	3	0.794	60*40*3
9300178	70	20	2	0.480	70*20*2
9300176	70	25	1.5	0.381	70*25*1.5
9300254	70	25	1.6	0.405	70*25*1.6
9300284	70	25	2.5	0.633	70*25*2.5
9300179	70	30	2	0.535	70*30*2
9300180	70	40	2	0.589	70*40*2
9300278	75	29.8	1.8	0.500	75*29.8*1.8
9300297	80	35	3	0.917	80*35*3
9300287	85	25	4	1.160	85*25*4
9300168	85	38	8	2.129	85*38*8
9300147	90	18	1.4	0.407	90*18*1.4
9300286	90	65	1.6	0.670	90*65*1.6
9300268	99.9	29.9	1.5	0.568	99.9*29.9*1.5
9300248	100	25	1.6	0.535	100*25*1.6
9300293	100	50	3	1.204	100*50*3
9300125	6	2	1	0.019	6*2*1
9300132	56	19.5	1.3	0.288	56*19.5*1.3
9300141	36.9	12.5	1.4	0.210	36.9*12.5*1.4
9300162	20	10	2	0.153	20*10*2
9300165	34.08	34.08	0.9	0.125	34.08*34.08*0.9



角铝系列 *L Shape Profile*



编号 Item No.	长 (A)	高 (H)	壁厚(T)	重量(KG/M)	规格S<长(A)*高(H)*壁厚(T)>
9300175	45	23.4	0.9	0.19	45*23.4*0.9
9300177	110	23.62	1.5	0.485	110*23.62*1.5
9300237	56	39	3	0.738	56*39*3
9300238	56	39	3	0.747	56*39*3
9300245	15	15	1.5	0.117	15*15*1.5
9300288	85	15.8	5	1.28	85*15.8*5
9300294-C	85	15.6	4.6	1.184	85*15.6*4.6
9300312	18	7.15	1	0.076	18*7.15*1
9300313	22	7.15	1	0.087	22*7.15*1
9300314	25	7.15	1	0.095	25*7.15*1
9300323	20	10	0.9	0.071	20*10*0.9
9300325	60	40	1	0.376	60*40*1
9300327	18	10	1.5	0.108	18*10*1.5
9300328	18	10	1.9	0.307	18*10*1.9
9300329	31.6	31.6	2.3	0.382	31.6*31.6*2.3
9300330	38	38	3.7	0.73	38*38*3.7
9300331	95	25	1.2	0.389	95*25*1.2
9300332	85	25	1.2	0.356	85*25*1.2
9300335	38	20	1.4	0.216	38*20*1.4
9300337	37	24.5	2	0.32	37*24.5*2
9300338	100	10.5	2	0.59	100*10.5*2
9300339	80	10.5	2	0.48	80*10.5*2
9300340	50.3	16.3	5.2	0.867	50.3*16.3*5.2
9300342	75	50	1.5	0.506	75*50*1.5

编号 Item No.	长 (A)	高 (H)	壁厚(T)	重量(KG/M)	规格S<长(A)*高(H)*壁厚(T)>
9300343	75	50	5	1.637	75*50*5
9300344	55	30	2	0.453	55*30*2
9300345	25	25	1.3	0.173	25*25*1.3
9300346	20	20	1.3	0.137	20*20*1.3
9300347	10	10	1.3	0.065	10*10*1.3
9300348	25	20	1.25	0.149	25*20*1.25
9300349	100	14.5	2	0.64	100*14.5*2
9300350	40	40	7	1.387	40*40*7

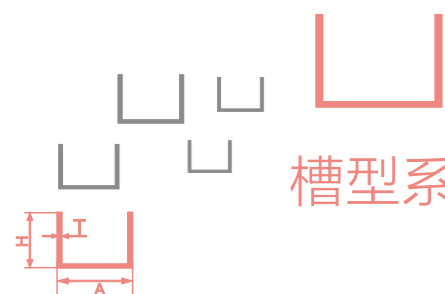

槽型系列 *U Channel Profile*

编号 Item No.	长 (A)	高 (H)	壁厚(T)	重量(KG/M)	规格S<长(A)*高(H)*壁厚(T)>
9800323	5	10	1	0.063	5*10*1
9800339	6	6	1	0.043	6*6*1
9800302	7.9	10	0.7	0.050	7.9*10*0.7
9800126	8	8	0.7	0.042	8*8*0.7
9800340	8	8	1	0.059	8*8*1
9800381	8	10	1	0.070	8*10*1
9800286	8	12	1	0.080	8*12*1
9800362	8.2	9.8	0.6	0.043	8.2*9.8*0.6
9800379	8.5	15	1.4	0.133	8.5*15*1.4
9800164	9	7	0.8	0.047	9*7*0.8
9800212	9.4	9.4	0.7	0.058	9.4*9.4*0.7
9800213	9.5	9.5	0.8	0.058	9.5*9.5*0.8
9800183	10	10	1	0.076	10*10*1
980035	10	10	1.5	0.111	10*10*1.5
9800361	10.1	18.85	0.65	0.082	10.1*18.85*0.65
9800382	11.7	6.8	0.8	0.051	11.7*6.8*0.8
9800210	12.6	12.6	0.9	0.097	12.6*12.6*0.9
9800211	12.7	12.7	1	0.097	12.7*12.7*1
980032	13	13	1.6	0.157	13*13*1.6
9800215	13	20	2.2	0.280	13*20*2.2
9800353	13.3	10.4	1.7	0.140	13.3*10.4*1.7
9800263	14	15.5	0.7	0.093	14*15.5*0.7
9800369	15	10	1.4	0.123	15*10*1.4
9800371	15	15	1	0.117	15*15*1

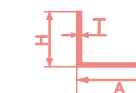

编号 Item No.	长 (A)	高 (H)	壁厚(T)	重量(KG/M)	规格S<长(A)*高(H)*壁厚(T)>
9800307	15	40	1.8	0.452	15*40.1*1.8
9800288	15.4	38	1.2	0.289	15.4*38*1.2
9800341	16	10	1	0.092	16*10*1
980033	16	16	1.6	0.196	16*16*1.6
9800230	17	7	4	0.195	17*7*4
9800332	17	19	1.4	0.199	17*19*1.4
9800367	18.3	19	1.7	0.245	18.3*19*1.7
9800349	18.4	31.75	3	0.621	18.4*31.75*3
9800303	18.8	6	1	0.077	18.8*6*1
9800342	19	10	1	0.100	19*10*1
9800343	19	15	1	0.127	19*15*1
980037	19	25.4	1.5	0.272	19*25.4*1.5
980038	19	38.1	1.5	0.376	19*38.1*1.5
9800231	19.7	10	1	0.103	19.7*10*1
9800370	20	10	1.4	0.142	20*10*1.4
980036	20	20	1.6	0.248	20*20*1.6
9800351	20.5	12	1	0.115	20.5*12*1
9800135	21.5	9	2.65	0.244	21.5*9*2.65
9800209	21.7	50	2.8	0.887	21.7*50*2.8
9800344	22	15	1	0.135	22*15*1
9800236	22	22	1.2	0.208	22*22*1.2
9800366	22.1	22.3	1.2	0.221	22.1*22.3*1.2
9800116	23.5	30	1.5	0.329	23.5*30*1.5
9800378	24	25.1	2	0.355	24*25.1*2

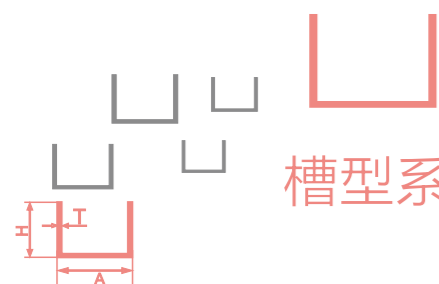

槽型系列 *U Channel Profile*

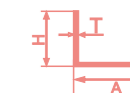

编号 Item No.	长 (A)	高 (H)	壁厚(T)	重量(KG/M)	规格S<长(A)*高(H)*壁厚(T)>
980040	25	25	1	0.199	25*25*1
980034	25	25	1.6	0.314	25*25*1.6
9800335	25	25	3	0.563	25*25*3
9800334	25	40	3	0.809	25*40*3
9800338	25.1	38.1	2	0.531	25.1*38.1*2
9800259	27.8	20	1.2	0.214	27.8*20*1.2
9800253	27.8	30	1.2	0.280	27.8*30*1.2
9800232	29	20	1.5	0.270	29*20*1.5
9800182	29.5	26	1.5	0.321	29.5*26*1.5
9800368	30	6	1	0.107	30*6*1
9800152	30	10	2	0.228	30*10*2
9800142	30	90	2.5	1.549	30*90*2.5
9800222	31.7	12.6	0.9	0.149	31.7*12.6*0.9
9800223	31.8	12.7	1	0.149	31.8*12.7*1
9800317	33.2	25	1.6	0.349	33.2*25*1.6
9800319	33.2	40	1.6	0.480	33.2*40*1.6
9800365	36	25	2.8	0.610	36*25*2.8
9800174	36	32	2.8	0.717	36*32*2.8
9800314	36.5	6	1	0.125	36.5*6*1
9800146	37	18	2	0.375	37*18*2
9800220	38	12.6	0.9	0.186	38*12.6*0.9
9800221	38.1	12.7	1	0.186	38.1*12.7*1
9800320	38.2	25	1.6	0.371	38.2*25*1.6
9800318	38.2	40	1.6	0.502	38.2*40*1.6

编号 Item No.	长 (A)	高 (H)	壁厚(T)	重量(KG/M)	规格S<长(A)*高(H)*壁厚(T)>
9800186	40	50	1.418	4.000	40*50*1.418
9800228	40.6	38	2.9	0.871	40.6*38*2.9
9800357	41.7	26.6	1.6	0.400	41.7*26.6*1.6
9800356	41.7	41.6	1.6	0.531	41.7*41.6*1.6
9800241	43.6	30	1.4	0.369	43.6*30*1.4
9800229	45.65	38	2.9	0.911	45.65*38*2.9
9800218	50.7	12.6	1.1	0.239	50.7*12.6*1.1
9800219	50.8	12.7	1.2	0.239	50.8*12.7*1.2
9800139	51	55	5	1.985	51*55*5
9800261	51.9	20	0.7	0.173	51.9*20*0.7
9800147	52	40	5	2.313	52*40*5
9800148	52	70	8	3.623	52*70*8
9800227	55	20	1.5	0.377	55*20*1.5
9800305	55	25	1.5	0.418	55*25*1.5
9800354	57.6	30	2	0.620	57.6*30*2
9800377	67.5	11.2	1.15	0.270	67.5*11.2*1.15
9800383	76	36	1	0.398	76*36*1
9800375	76	38	1	0.409	76*38*1
9800350	100	76	6	3.930	100*76*6
9800216	101.5	12.6	1.1	0.404	101.5*12.6*1.1
9800217	101.6	12.7	1.2	0.401	101.6*12.7*1.2
9800296	120	25	1.1	0.504	120*25*1.1
9800113	31.7	9.4	1	0.172	31.7*9.4*1
9800119	10	9	0.7	0.059	10*9*0.7

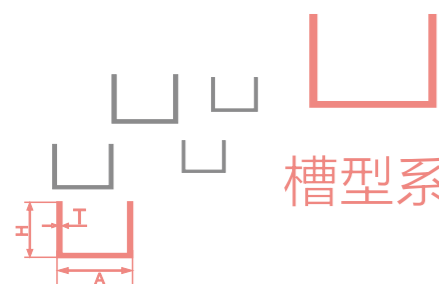

槽型系列 *U Channel Profile*

编号 Item No.	长 (A)	高 (H)	壁厚 (T)	重量 (KG/M)	规格S<长(A)*高(H)*壁厚(T)>
9800127	45	30	2	0.709	45*30*2
9800128	19.7	26.6	1	0.213	19.7*26.6*1
9800131	25.4	27	1.4	0.314	25.4*27*1.4
9800134	8	50	2	0.377	8*50*2
9800140	25.4	25.4	1.5	0.368	25.4*25.4*1.5
9800144	38.5	52.5	3.5	1.259	38.5*52.5*3.5
9800145	25	6	3.5	0.382	25*6*3.5
9800162	20	19	0.8	0.131	20*19*0.8
9800173	35.5	10	5	0.616	35.5*10*5
9800175	53	21	1	0.264	53*21*1
9800191	19.05	15.3	2.54	0.295	19.05*15.3*2.54
9800193	44	16	3	0.48	44*16*3
9800203	26	8	0.7	0.086	26*8*0.7
9800206	9.9	4.18	0.7	0.036	9.9*4.18*0.7
9800225	24.5	19.48	1.6	0.217	24.5*19.48*1.6
9800242	60	34	2	0.764	60*34*2
9800257	15.8	3.8	3	0.138	15.8*3.8*3
9800260	18	25	2	0.355	18*25*2
9800262	76.7	39	1.1	0.570	76.7*39*1.1
9800267	40.5	9.4	2.4	0.315	40.5*9.4*2.4
9800268	37.5	8.2	1.5	0.285	37.5*8.2*1.5
9800269	6.5	25	1.2	0.185	6.5*25*1.2
9800271	19	3	1	0.06	19*3*1
9800274	40.1	6.4	1	0.131	40.1*6.4*1

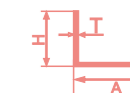

编号 Item No.	长 (A)	高 (H)	壁厚 (T)	重量 (KG/M)	规格S<长(A)*高(H)*壁厚(T)>
9800276	20.4	4.4	1	0.067	20.4*4.4*1
9800277	24	7	1	0.115	24*7*1
9800281	15	10.2	3.15	0.279	15*10.2*3.15
9800282	10	11.8	1	0.062	10*11.8*1
9800289	3.4	9.8	0.1	0.038	3.4*9.8*0.1
9800294	22.6	11.6	0.8	0.121	22.6*11.6*0.8
9800301	16	3.8	2.5	0.123	16*3.8*2.5
9800308	65	10	1	0.249	65*10*1
9800309	90	10	1	0.317	90*10*1
9800310	75	10	1	0.276	75*10*1
9800312	40	14	1.3	0.324	40*14*1.3
9800313	26	40	1.3	0.409	26*40*1.3
9800314	36.5	6	1	0.125	36.5*6*1
9800315	26	40	1.3	0.402	26*40*1.3
9800316	33.2	40	1.6	0.480	33.2*40*1.6
9800324	24.2	35.1	5	1.04	24.2*35.1*5
9800327	13.98	25	1.2	0.2	13.98*25*1.2
9800328	20	14.86	1	0.095	20*14.86*1
9800333	15	20	1.5	0.224	15*20*1.5
9800334	25	40	3	0.809	25*40*3
9800345	16	7	1	0.092	16*7*1
9800346	16	10	1	0.116	16*10*1
9800347	16	12	1	0.132	16*12*1
9800348	20	18	1	0.193	20*18*1

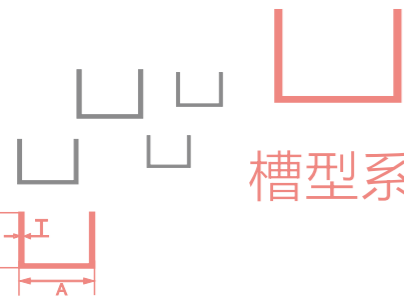

槽型系列 *U Channel Profile*

编号 Item No.	长 (A)	高 (H)	壁厚 (T)	重量 (KG / M)	规格 S<长 (A)*高 (H)*壁厚 (T) >
9800352	29.8	15	0.6	0.119	29.8*15*0.6
9800358	34.2	40	1.6	0.484	34.2*40*1.6
9800359	53.3	65	1.5	0.738	53.3*65*1.5
9800360	34.2	40	1.6	0.484	34.2*40*1.6
9800363	54.7	45	1	0.415	54.7*45*1
9800385	58	45	1.4	0.55	58*45*1.4
9800392	15	30	1.5	0.306	15*30*1.5
9800397	22.8	24	1.4	0.255	22.8*24*1.4
9800400	12.6	5.6	0.8	0.048	12.6*5.6*0.8
9800401	27.5	21	3	0.606	27.5*21*3
9800402-C	59.8	29.9	1.9	0.609	59.8*29.9*1.9
9800403-C	89.8	29.9	1.9	0.97	89.8*29.9*1.9
9800404	62.3	8	2	0.372	62.3*8*2
9800405	20	18	1	0.147	20*18*1
9800406	20	5	0.9	0.083	20*5*0.9
9800407-C	26.3	22.9	1.4	0.264	26.3*22.9*1.4
9800409-C	51.1	22.9	1.2	0.309	51.1*22.9*1.2
980096	25.4	25.4	1.83	0.386	25.4*25.4*1.83
980097	27	25.4	1.5	0.345	27*25.4*1.5



