

Miniature photoelectric sensor PST series



Feature description

- M3 threaded cylindrical installation, small size, easy to install and use
- With 360° visible bright LED status indicator
- Good anti-light interference, high product stability
- Retro-reflective, stable detection of translucent and opaque objects



Model specification

NPN NO	PST-DC25DNOR-F3	PNP NO	PST-DC25DPOR-F3
NPN NC	PST-DC25DNCR-F3	PNP NC	PST-DC25DPCR-F3

Specifications

Sensing distance	25cm※	Response time	<1ms
Min target	φ1mm opaque or translucent objects above	Anti ambient light	Sunlight interference ≤10,000 lux
Spot size	10mm@25cm		Incandescent light interference ≤3,000 lux
Supply voltage	10...30VDC	Operation temperature	-20...55°C
Consumption current	≤15mA	Storage temperature	-30...70 °C
Load current	≤50mA	Protection degree	IP67
Voltage drop	≤1.5V	In conformity with standards	CE
Light source	Red light(640nm)	Shell material	ABS
Protection circuit	Short circuit,reverse polarity,overload protection	Lens	PMMA
Indicator	Green:power supply indicator,stability indication	Connection	2m PVC cable+M8 connector
	Yellow:output indication	Accessory	Screws(M3×16mm)×2、Nut×2、Reflector(TD-11)、Operation manual

※ Use reflectors TD-11

Dimension

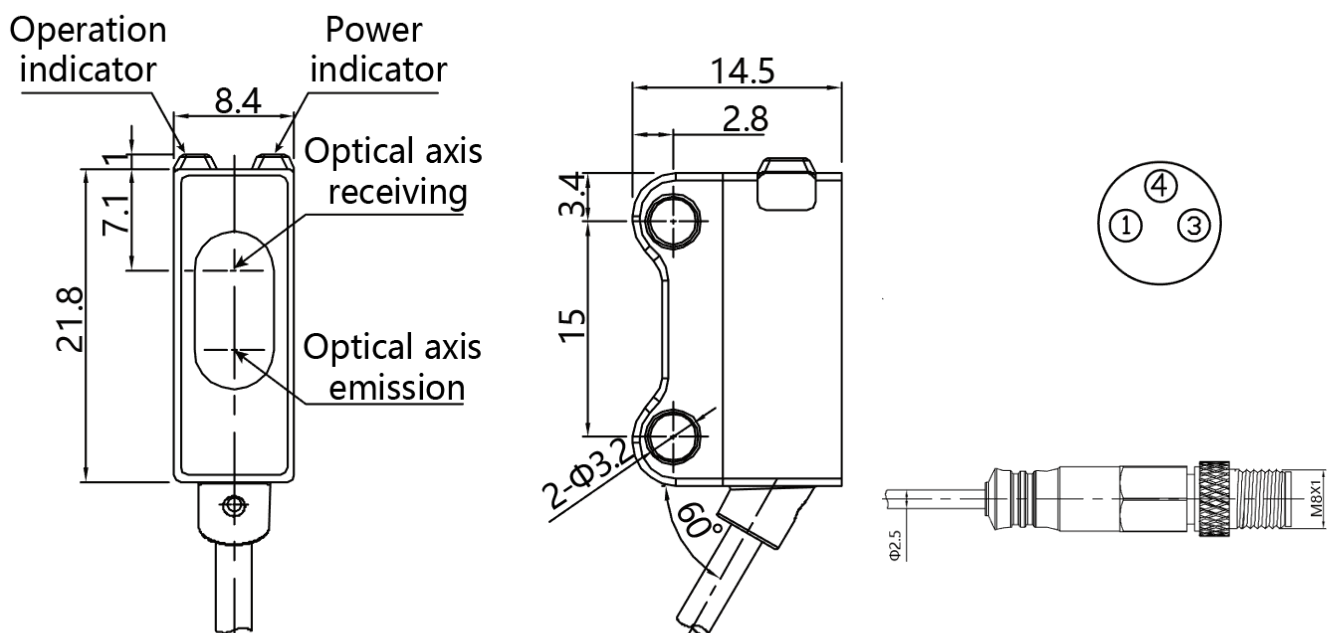

Wiring diagram

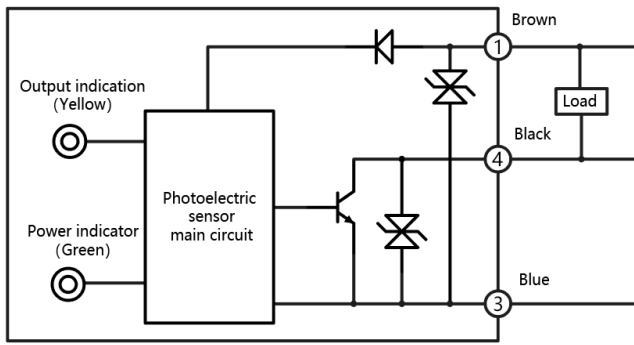

NPN

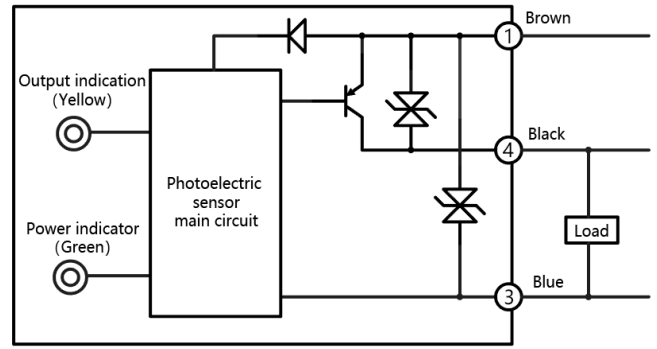

PNP