

REVISED	DATE	DESCRIPTION

Front view

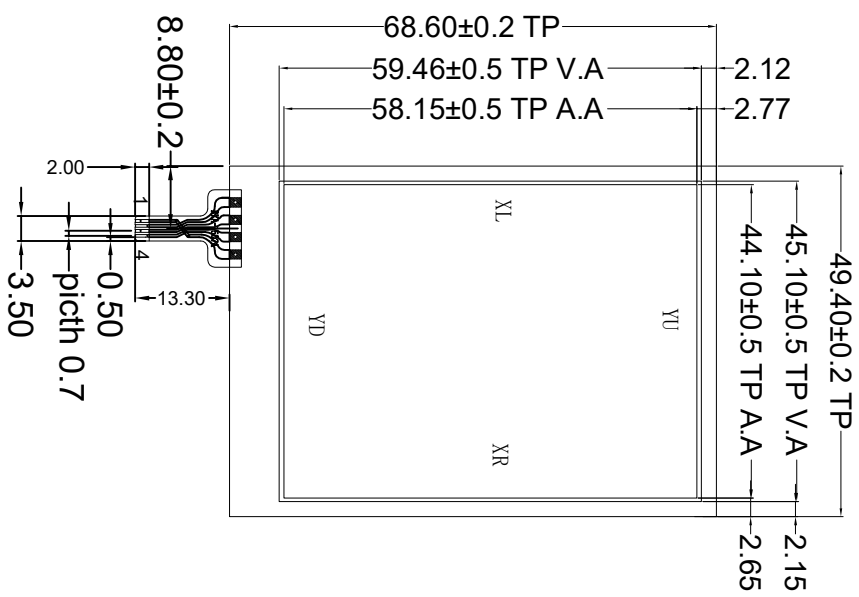

Side view

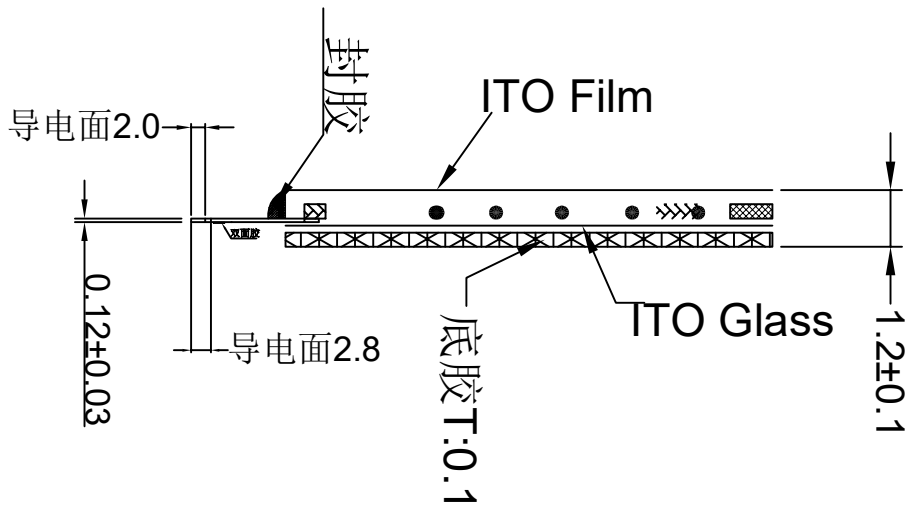

Back view

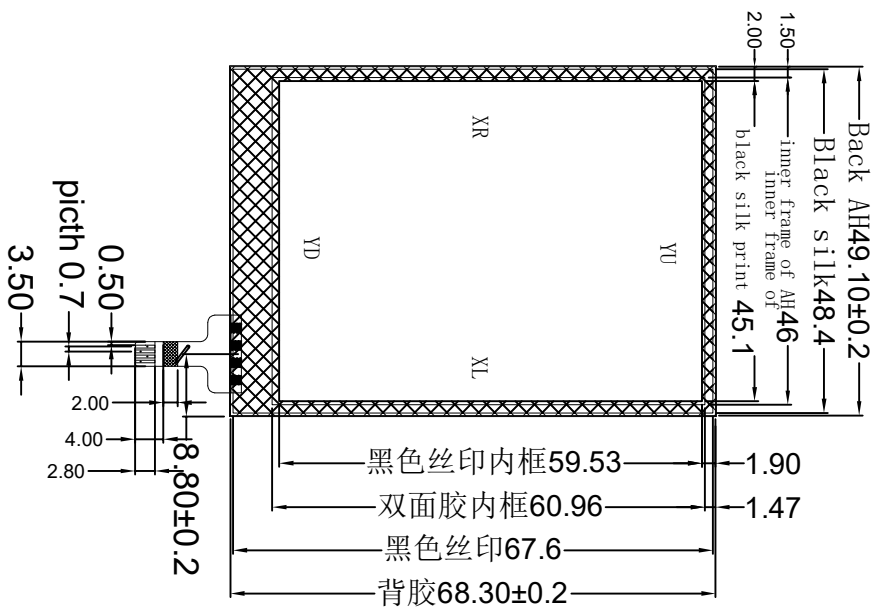

Technical parameters:

1. Structure: films+glass+FPC (Matte anti-scratch)
2. ITO Film type: Anti-glare and anti-newton ring coating
3. Circuit level: DC5V 1mA
4. Surface hardness: ≤3H
5. Linear: ≤1.5%
6. Transparent rate: ≥80%
7. Operating pressure: 50-80g
8. Operational life span: ≥1,000,000h
9. Operating temperature: -20°C~+70°C
10. Storage temperature: -30°C~+80°C
11. Unmarked tolerance: ±0.2mm
12. X: 180-1100Ω Y: 180-1100Ω
13. Meet ROHS environmental requirements

pin out	
1	YU
2	XL
3	YD
4	XR

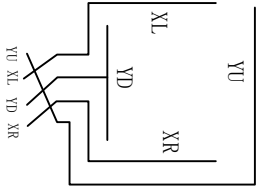

SCALE: 1 : 1 NOT TO SCALE	UNITS MM	<p>Reshine Display (HK) Technology Co., Limited</p>
PAGE:		
GENERAL TOL. 0.20mm		Tel: 0755-29190292 Fax: 0755-29190291
APPROVALS	DATE	MODEL NUMBER :
APP Mychan	2014/04/07	RXA-028004-01
CHK Amor11	2014/04/07	Product NO :
		DATE: 2014/04/07
		PROJECTION