

# WYT-R导轨安装系列\WYT-R Rail Mount Series

推荐提升高度(Height): ≤90m      能效等级Energy Efficiency Grade: 3

系列Series	规格Type	载重Capacity (kg)	轿厢速度Speed (m/s)	曳引轮直径Sheave (mm)	槽数Num	绳径(mm)	槽间距Pitch (mm)	额定电流Current (A)	额定转速Motor Speed (rpm)	额定频率Frequency (Hz)	额定功率Power (kW)	额定转矩Torque (Nm)	最大轴负荷Shaft Load (kg)	主机重量Weight (kg)
WYT-R	CN1.0B	630	1.0	φ 400	4	φ 10	15	10.4	96	24	4.6	460	4000	≈450
	CN1.5B		1.5					16.7	144	36	6.9			
	CN1.6B		1.6					17.1	153	38.3	7.4			
	CN1.75B		1.75					17.8	168	42	8.1			
	CN2.0B		2.0					20.2	192	48	9.3			
	CN1.0BL	630	1.0	φ 480	4	φ 10	15	10.4	80	19.9	4.6	550		
	CN1.5BL		1.5					16.7	119	29.8	6.9			
	CN1.6BL		1.6					17.1	127	31.8	7.4			
	CN1.75BL		1.75					17.8	139	34.8	8.1			
	CN2.0BL		2.0					20.2	159	39.8	9.2			
	CN1.0C	800	1.0	φ 400	5	φ 10	15	12	96	24	5.2	520		
	CN1.5C		1.5					20.0	144	36	7.8			
	CN1.6C		1.6					20.4	153	38.3	8.3			
	CN1.75C		1.75					20.7	168	42	9.1			
	CN2.0C		2.0					23.0	192	48	10.5			
	CN1.0CL	800	1.0	φ 480	5	φ 10	15	11.2	80	19.9	5.1	605		
	CN1.5CL		1.5					20.4	119	29.8	8.3	665		
	CN1.6CL		1.6					20.8	127	31.8	8.8			
	CN1.75CL		1.75					21.2	139	34.8	9.7			
	CN2.0CL		2.0					24	159	39.8	11			
	CN1.0D	1000	1.0	φ 400	5	φ 10	15	13.8	96	24	6.1	605		
	CN1.5D		1.5					25	144	36	10	665		
	CN1.6D		1.6					25.5	153	38.3	10.7			
	CN1.75D		1.75					26.2	168	42	11.7			
	CN2.0D		2.0					29.8	192	48	13.4			
	CN1.0DL	1000	1.0	φ 480	5	φ 10	15	15.1	80	19.9	6.7	800		
	CN1.5DL		1.5					25	119	29.8	10			
	CN1.6DL		1.6					25.2	127	31.8	10.7			
	CN1.75DL		1.75					25.6	139	34.8	11.7			
	CN2.0DL		2.0					29	159	39.8	13.3			
	CN1.0E	1150	1.0	φ 400	5	φ 10	15	17.2	96	24	7.7	765		
	CN1.5E		1.5					28.3	144	36	11.5			
	CN1.6E		1.6					28.7	153	38.3	12.3			
	CN1.75E		1.75					29.5	168	42	13.4			
	CN2.0E		2.0					33	192	48	15.4			
	CN1.0EL	1150	1.0	φ 480	5	φ 10	15	17	80	19.9	7.5	900		
	CN1.5EL		1.5					28.3	119	29.8	11.2			
	CN1.6EL		1.6					28.7	127	31.8	12			
	CN1.75EL		1.75					29.6	139	34.8	13.2			
	CN2.0EL		2.0					32.3	159	39.8	15.1			
	CN1.0F	1275	1.0	φ 400	5	φ 10	15	18.2	96	24	8.2	820		
	CN1.5F		1.5					28.4	144	36	12.4			
	CN1.6F		1.6					29	153	38.3	13.1			
	CN1.75F		1.75					31.5	168	42	14.4			
	CN2.0F		2.0					36.7	192	48	16.5			

## 主机技术参数 (Parameter of Traction Machine) :

额定电压 (Voltage) : AC380V  
 悬挂比 (Suspension) : 2: 1  
 钢丝绳绕法 (Rope) : 单绕 (Single)  
 额定载重量 (Capacity) : 630kg~1275kg  
 轿厢速度 (Speed) : 1.0m/s~2.0m/s  
 防护等级 (Prot. Class) : IP41  
 绝缘等级 (Ins. Class) : F  
 曳引机极数 (Traction machine pole) : 30  
 启动频次 (次/小时, Stars per hour) : 240  
 工作制 (Rating) : S5-40%

## 制动器技术参数 (Parameter of Brake) :

型号 (Model) : BLB  
 绝缘等级 (Ins. Class) : F  
 额定电压 (Voltage) : DC110V  
 额定电流 (Current) :

载重kg (Capacity)	额定电流 (Current)
630kg	1.1A
800kg-1275kg	1.3A

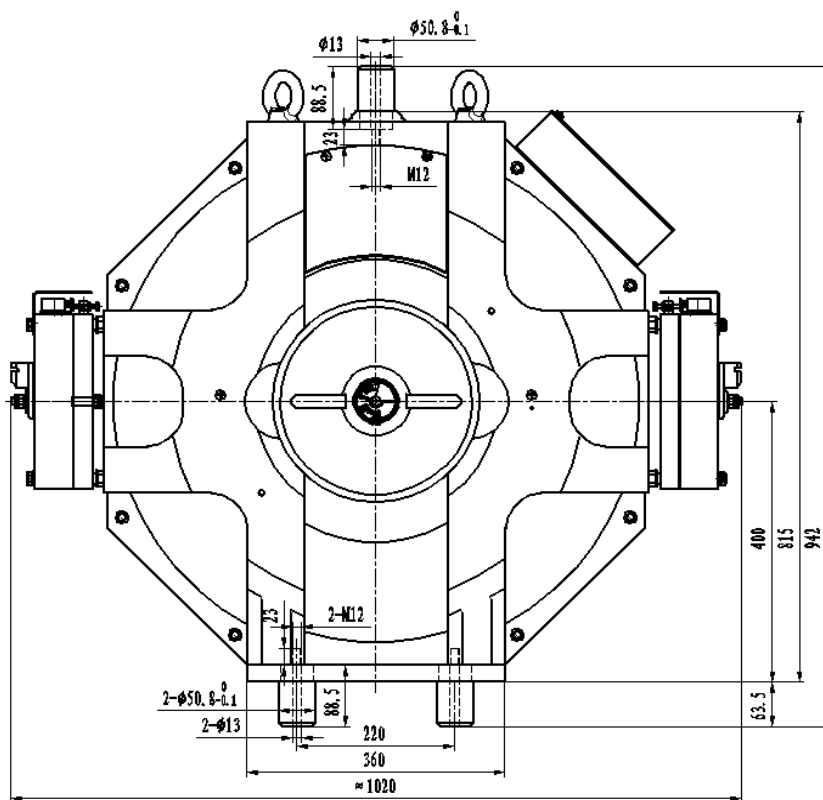
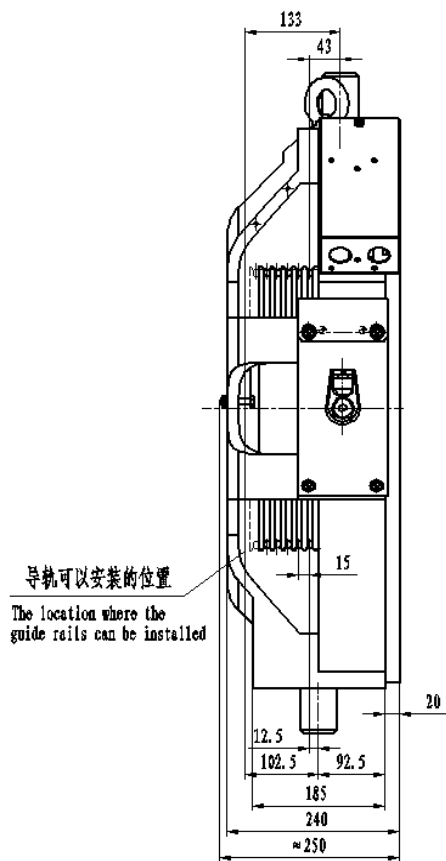

外观尺寸图 Outline drawing