

- South China office: 13940069968
- East China office: 18602456256
- Foreign Trade Center: 86-024-83786420 E-mail: zhangruiyan@sylg.cn

SHENYANG BLUELIGHT DRIVE THE FUTURE

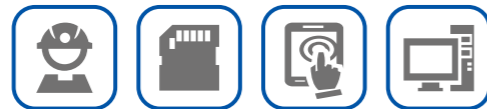

[HTTP://WWW.SYLG.CN](http://www.sylg.cn)

Revised May 2024

Shenyang Bluelight Drive Technology Co.,Ltd.

TEL: (024)-83863349 / (024)-56615603
ADD: No.37 Shiji Road, Hunnan New District,
Shenyang, China ZIP: 110179



ABOUT US

- Established in 1989, Bluelight is a leading manufacturer of elevator control systems and gearless permanent magnet synchronous machines. It is member of China Elevator Association and an enterprise certified by ISO9001.
- Shenyang BlueLight has also built production base in Guangdong and Zhejiang province. Guangdong Plant has floor space of 10,000 m² with annual production capacity 30,000 units. Zhejiang Plant has floor space of 10,000 m² with annual production capacity 30,000 units.
- From 1998, Shenyang Bluelight started development of gearless permanent magnet synchronous machines. With a R&D team leading by two doctors experts in motor, Bluelight cooperated constantly with domestic universities, overseas well-known companies for exchange of technology and successfully developed the first gearless permanent magnet synchronous machines in October, 2000. After several technical improvements, Bluelight passed the national EMC testing in July, 2001 and successfully obtained certification. Meanwhile, the machines had been launched into mass production. Shenyang Bluelight has granted several patents of gearless permanent magnet synchronous machines and owned all the knowledge property rights.
- Nowadays, Bluelight gearless machines are widely used in China and some of the products have been sold to Europe, America, Korea, Japan, Taiwan, Middle East, Southeast Asia etc. Relying on the excellent characteristics such as low noise, low vibration, smooth and comfortable running etc., Bluelight gearless machines are being recognized by more and more elevator manufacturers.



Shenyang Head Quarters



Fushun Plant



Zhaoqing Plant



Zhejiang Plant

COMPANY QUALIFICATION

1. ISO9001
2. KTL Issue KC Certification
3. National high-tech Enterprise
4. China Invention Exhibition
5. Type-examination Certificate of Special Equipment
6. Patent Certificate
7. CE Certification



1



2



3



4



5



6



7



01 WYT-T STANDARD SERIES

- WYT-T PM TRACTION MACHINE (TS/TF/TD/TE)

----- 01/06

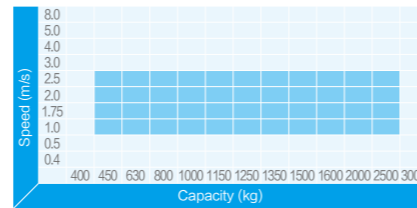

02 WYT-L COMFORTABLE SERIES

- WYT-L MACHINE ROOMLESS VERSION

----- 07/10

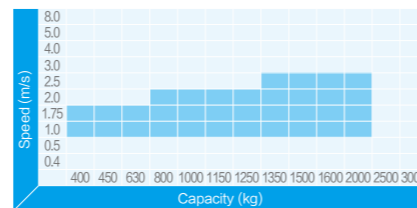

03 WYT-TD/TE/V/V1S FREIGHT ELEVATOR SERIES

- WYT(TD/TE/V/V1S) FREIGHT ELEVATOR VERSION

----- 11/18

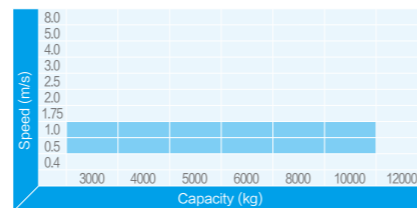

04 WYT-J/H HIGH SPEED SERIES

- WYT-J DOUBLE WRAP VERSION

----- 19/20

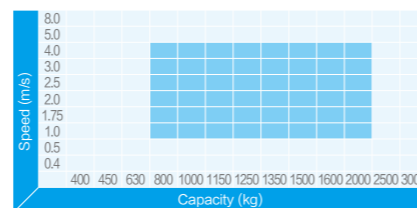

- WYT-H ULTRA-HIGH SPEED VERSION

----- 21/22



MACHINE TYPE RECOMMENDATION TABLE

05 WYT-V/V1S HEAVY LOAD SERIES

- WYT-V

----- 23/24

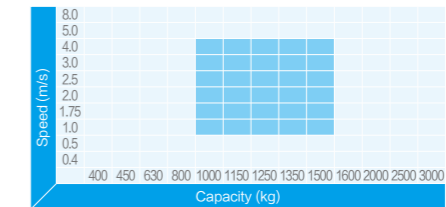

- WYT-V1S

----- 25/26

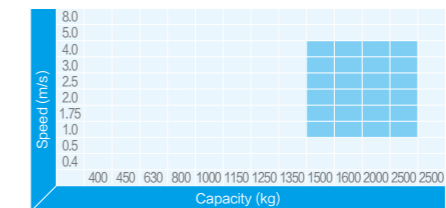

06 WYT-R RAIL MOUNT SERIES

- WYT-R RAIL MOUNT VERSION

----- 27/28

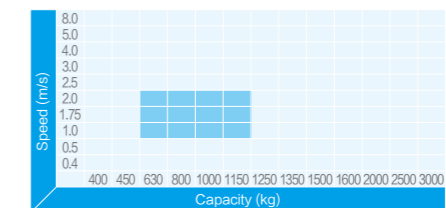

07 WYT-K/F BELT MACHINE SERIES

- WYT-K COMMERCIAL ELEVATOR VERSION

----- 29/31

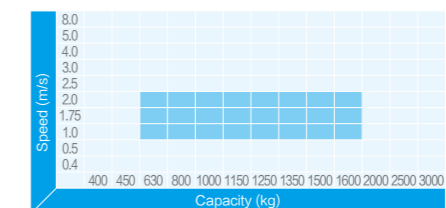

- WYT-F VILLA VERSION

----- 32/34

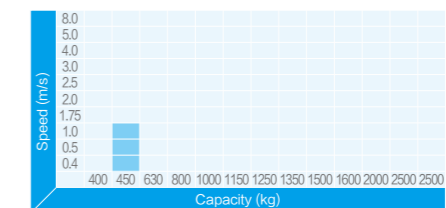

- ACCESSORIES (BELT, SHACKLES, WHEEL ASSEMBLY, BELT DETECTOR)

WYT-T STANDARD SERIES



WYT-T PM Traction Machine

WYT-T series outer rotor PMS machine is Bluelight's most popular product. After 10 years of continuous improvement, this series product has high quality standard, with superior performance, and can cover wide range of elevator application. It is your first choice for high performance elevator.

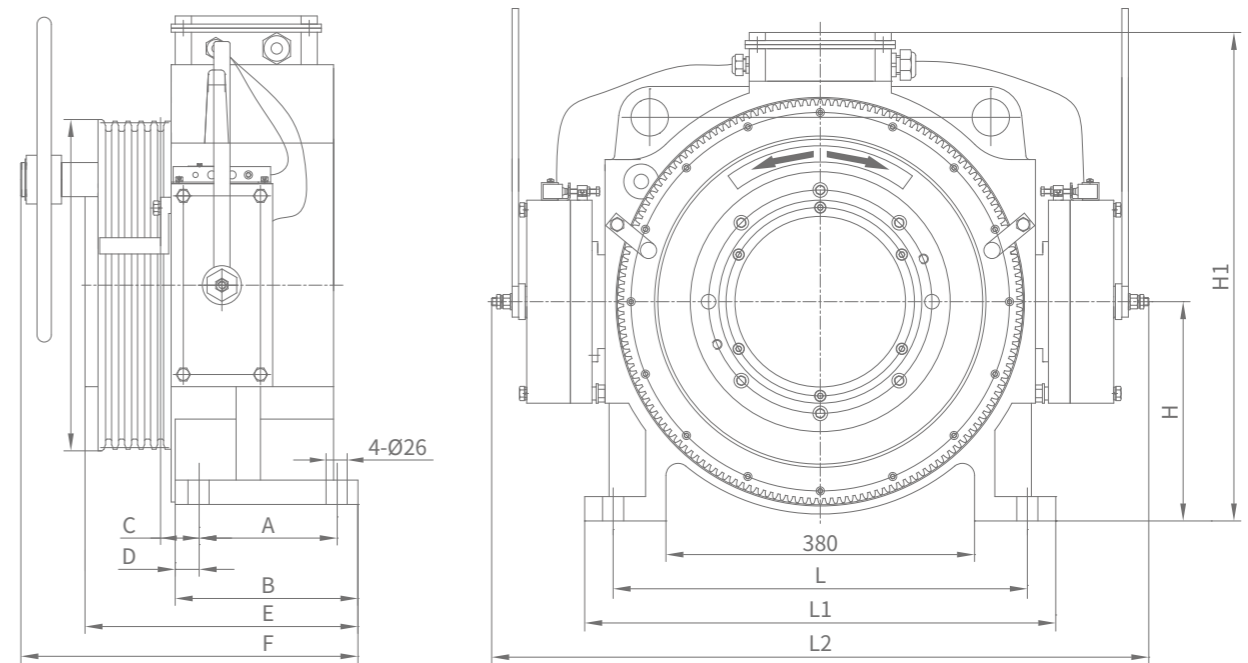

Outline drawing

Parameter of Traction Machine

Voltage: AC380V
Roping: 2 : 1
Wrap: Single
Capacity: 450kg ~ 2500kg
Speed: 1.0m/s ~ 2.5m/s
Protection Grade: IP41
Ins. Class: F
Traction machine pole: 30
Stars per hour: 240
Rating: S5-40%

Features

- Optimized mechanical structure design, high shaft load, high operating safety factor;
- High efficiency, high torque density design and optimized pole slot coordination;
- Machine run smoothly, with low noise & small vibration;
- This series covers wide range of elevator speed & capacity;
- Use block type armless brake, it has fast response time & high reliability.

Parameter of Brake

Model: BLB Ins.Class: F Voltage: DC110V
Current:

Series	Model	Speed (m/s)	Capacity code	Current
WYT-T		1.0 ~ 2.0	A, B, AS, BS, CS, DS, (450kg ~ 1000kg)	1.1A
			C, CL, D, DL, E, (800kg ~ 1150kg)	1.3A
	D	1.0 ~ 2.5	C, CL, D, DL, E, EL (800kg ~ 1150kg)	1.6A
			F, FL, G, GL, H, HL (1275kg ~ 1600kg)	1.6A
	E	1.0 ~ 2.5	A, B, C, D, E, F (1000kg ~ 2000kg)	1.6A
			CL, DL, EL (1275kg ~ 1600kg)	1.6A
FL (2000kg)			1.98A	
		1.0 ~ 2.5	G, GL (2500kg)	1.98A

- Standard Series
- WYT-T
- WYT-TS
- WYT-TF
- WYT-TD
- WYT-TE
- Comfortable Series
- WYT-L
- Freight Elevator Series
- WYT-TD
- WYT-TE
- WYT-V
- WYT-VIS
- High Speed Series
- WYT-J
- WYT-H
- Heavy Load Series
- WYT-V
- WYT-VIS
- Rail Mount Series
- WYT-R
- Belt Machine Series
- WYT-K
- WYT-F
- The Parameter List of Groove

WYT-TS Light Duty

Height: ≤80m

Series	Model	Capacity (kg)	Speed (m/s)	Sheave (mm)	Num	(mm)	Pitch (mm)	Current (A)	Motor Speed (rpm)	Frequency (Hz)	Power (kW)	Torque (Nm)	Shaft Load (kg)	Weight (kg)	Dimension(mm)															
															A	B	C	D	E	F	G	H	H1	H2	H3	L	L1	L2	M	N
WYT-T	1.0AS	450	1.0	φ 350	5	φ 8	12	7.2	109	27.3	3.1	270	2500	≈300	140	195	47.5	29.5	328	390	420	270	497	540	605	510	580	800	56	30
	1.5AS		11					164	41	4.6																				
	1.6AS		11.3					175	43.7	4.9																				
	1.75AS		11.7					191	47.7	5.4																				
	1.0BS	630	1.0	φ 350	5	φ 8	12	9.4	109	27.3	4.2	370																		
	1.5BS	15.2	164					41	6.4																					
	1.6BS	15.4	175					43.7	6.8																					
	1.75BS	16.1	191					47.7	7.4																					
	1.0CS	800	1.0	φ 350	6	φ 8	12	12	109	27.3	5.3	460																		
	1.5CS	20.2	164					41	7.9																					
	1.6CS	20.5	175					43.7	8.4																					
	1.75CS	20.8	191					47.7	9.2																					
	1.0DS	1000	1.0	φ 350	6	φ 8	12	14.4	109	27.3	6.4	560																		
	1.5DS	23.8	164					41	9.6																					
	1.6DS	24.2	175					43.7	10.3																					
1.75DS	25	191	47.7					11.2																						

Recommended single groove V

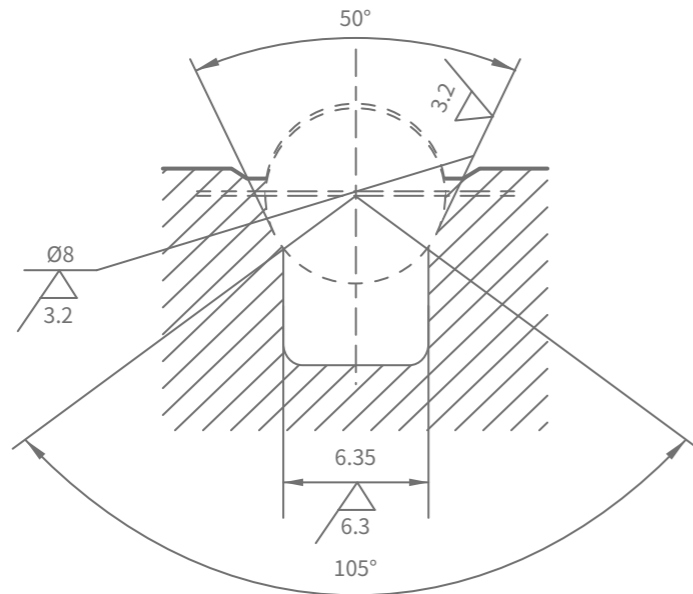

Outline drawing

WYT-TF Standard Version

Height: ≤90m

Series	Type	Capacity (kg)	Speed (m/s)	Sheave (mm)	Num	(mm)	Pitch (mm)	Current (A)	Motor Speed (rpm)	Frequency (Hz)	Power (kW)	Torque (Nm)	Shaft Load (kg)	Weight (kg)	Dimension(mm)													
															A	B	C	D	E	F	H	H1	L	L1	L2			
WYT-T	1.0A	450	1.0	φ 400	4	φ 10	16	7.5	96	24	3.2	320	2500	≈300	140	195	47.5	29.5	337	398	270	605	510	580	800	56	30	
	1.5A		11					144	36	4.8																		
	1.6A		11.4					153	38.3	5.1																		
	1.75A		12.1					168	42	5.6																		
	2.0A	14.2	192	48	6.4																							
	1.0B	630	1.0	φ 400	4	φ 10	16	10.2	96	24	4.6	460																
	1.5B	16.4	144					36	6.9																			
	1.6B	16.8	153					38.3	7.4																			
	1.75B	17.6	168					42	8.1																			
	2.0B	20	192	48	9.3																							
	1.0C	800	1.0	φ 400	5	φ 10	16	11.8	96	24	5.2	520																
	1.5C	19.8	144					36	7.8																			
	1.6C	20.2	153					38.3	8.3																			
	1.75C	20.5	168					42	9.1																			
	2.0C	22.7	192	48	10.5																							
	1.0CL	800	1.0	φ 480	5	φ 10	16	11	80	19.9	5.1	605																
	1.5CL	20.2	119					29.8	8.3																			
	1.6CL	20.6	127					31.8	8.8																			
	1.75CL	21	139					34.8	9.7																			
	2.0CL	23.8	159	39.8	11																							
	1.0D	1000	1.0	φ 400	5	φ 10	16	13.6	96	24	6.1	605																
	1.5D	24.8	144					36	10																			
	1.6D	25.3	153					38.3	10.7																			
	1.75D	26	168					42	11.7																			
2.0D	29.6	192	48	13.4																								
1.0DL	1000	1.0	φ 480	5	φ 10	16	14.9	80	19.9	6.7	800																	
1.5DL	24.7	119					29.8	10																				
1.6DL	25	127					31.8	10.7																				
1.75DL	25.4	139					34.8	11.7																				
2.0DL	28.7	159	39.8	13.3																								
1.0E	1150	1.0	φ 400	6	φ 10	16	17	96	24	7.7	765																	
1.5E	28.1	144					36	11.5																				
1.6E	28.5	153					38.3	12.3																				
1.75E	29.3	168					42	13.4																				
2.0E	32.7	192	48	15.4																								

Standard Series

WYT-T
WYT-TS
WYT-TF
WYT-TD
WYT-TE

Comfortable Series

WYT-L

Freight Elevator Series

WYT-TD
WYT-TE
WYT-V
WYT-VIS

High Speed Series

WYT-J
WYT-H

Heavy Load Series

WYT-V
WYT-VIS

Rail Mount Series

WYT-R

Belt Machine Series

WYT-K
WYT-F

The Parameter List of Groove

WYT-L COMFORTABLE SERIES



WYT-L Machine Roomless Version

WYT-L series products are the new generation inner rotor structure PM gearless traction machine developed by Bluelight in 2019. It is suitable for mini machine room or machine roomless elevator application. The standard products of the WYT-L series are level 3 energy efficiency, and can provide level 2 energy efficiency products according to customer requirements.



Parameter of Traction Machine

Voltage: AC380V
Roping: 2 : 1
Wrap: Single
Capacity: 408kg ~ 2000kg
Speed: 1.0m/s ~ 2.5m/s
Protection Grade: IP41
Ins. Class: F
Traction machine pole: 20
Stars per hour: 240
Rating: S5-40%

Features

- Special silent design for MMR or MRL.
- For some sites where the top level is insufficient and difficult to wire, a removable junction box is standard;
- Further improves heat dissipation.
- High efficiency and high torque density design with high material utilization, small size and light weight.
- The inner rotor structure improves electromagnetic structure, result smooth low speed running and high overload capacity.
- Use shaft brake, with the advantage of compact structure, low braking noise and fast response time.

Parameter of Brake

Model: BLS Ins.Class: F Voltage: DC110V
Current:

Capacity	Current
408kg ~ 1350kg	1.5A×2
1350kg ~ 2000kg	2.2A×2

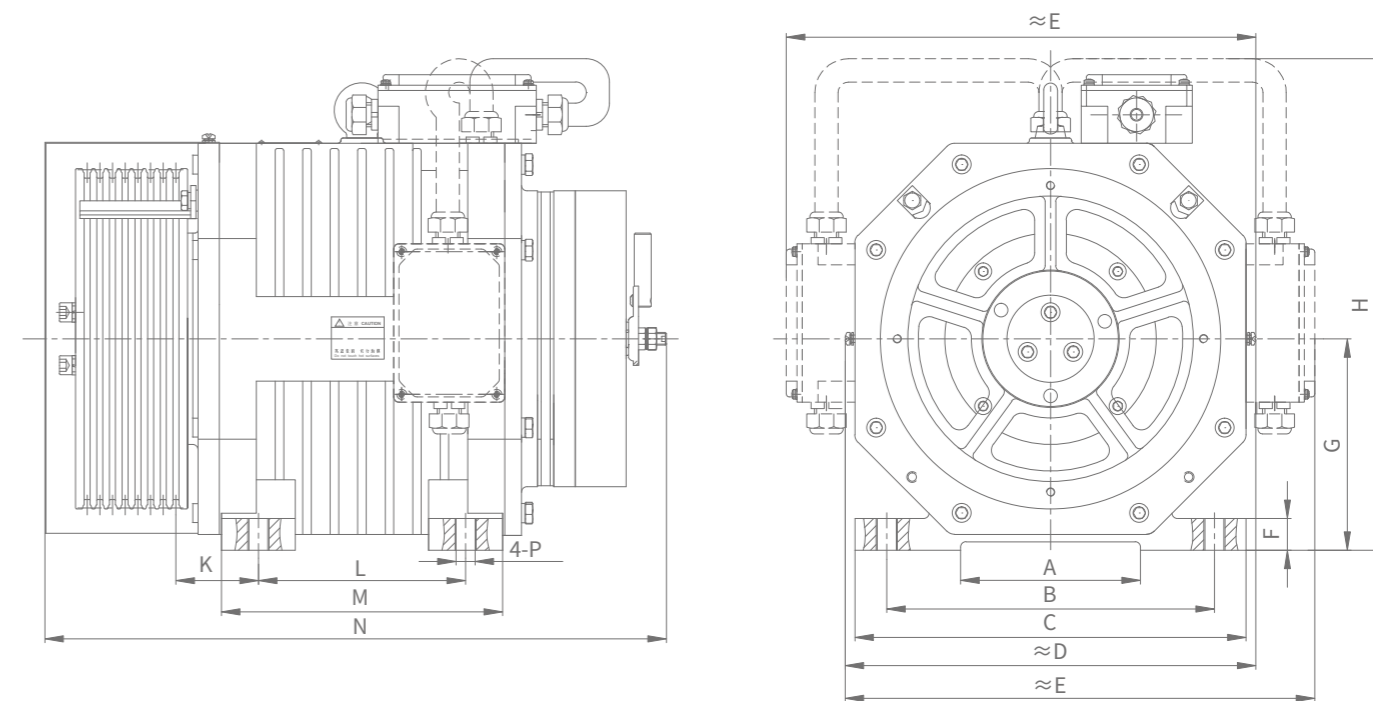

Remark: The machine junction box can be installed on the top or left or right side of the host, as shown in the above outline drawing.

Outline drawing

Standard Series
WYT-T
WYT-TS
WYT-TF
WYT-TD
WYT-TE

Comfortable Series
WYT-L

Freight Elevator Series
WYT-TD
WYT-TE
WYT-V
WYT-VIS

High Speed Series
WYT-J
WYT-H

Heavy Load Series
WYT-V
WYT-VIS

Rail Mount Series
WYT-R

Belt Machine Series
WYT-K
WYT-F

The Parameter List of Groove

WYT - TD / TE / V / V1S FREIGHT ELEVATOR SERIES

WYT-TD Freight Elevator Version (3t)

Parameter of Traction Machine

Voltage: AC380V
 Roping: 4 : 1
 Wrap: Single
 Capacity: 3000kg
 Speed: 0.5m/s ~ 1.0m/s
 Protection Grade: IP41
 Ins. Class: F
 Traction machine pole: 30
 Stars per hour: 120
 Rating: S5-40%



Parameter of Brake

Model: BLB Ins.Class: F Voltage: DC110V Current: 1.6A

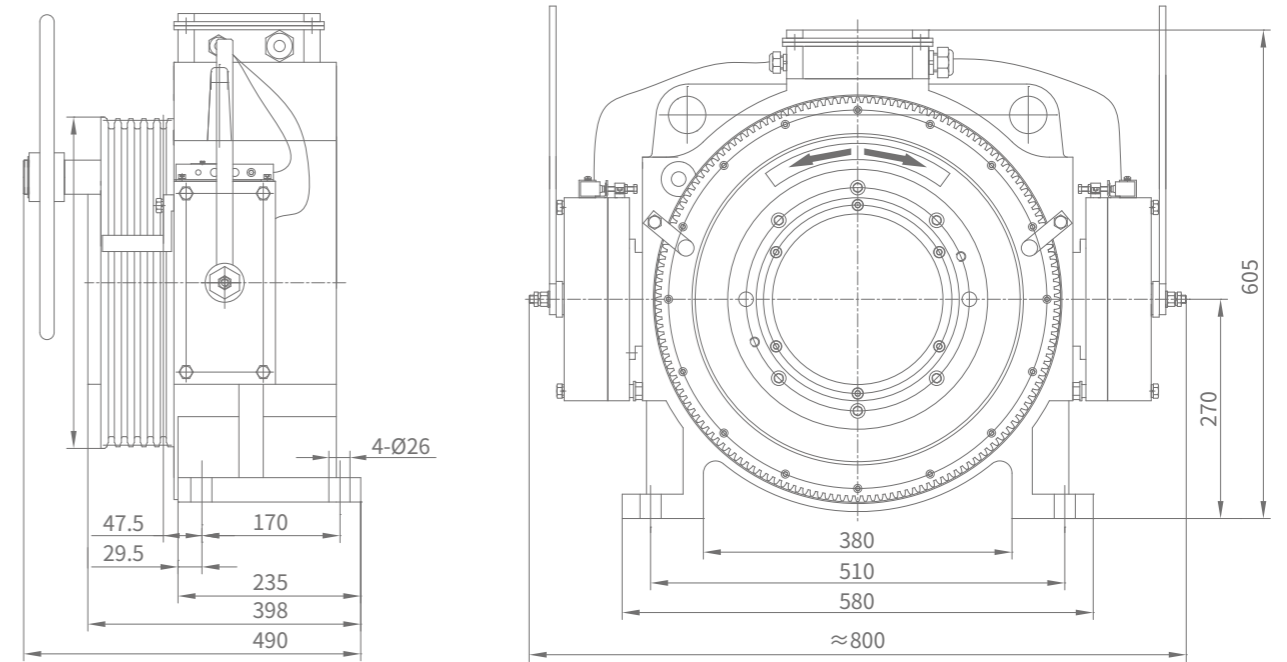

Outline drawing

WYT-TD Freight Elevator Version(3t)

Height: ≤45m

Series	Type	Capacity (kg)	Speed (m/s)	Sheave (mm)	Num	(mm)	Pitch (mm)	Current (A)	Motor Speed (rpm)	Frequency (Hz)	Power (kW)	Torque (Nm)	Shaft Load (kg)	Weight (kg)
WYT-T	ND0.5-3	3000	0.5	φ 400	7	φ 10	16	23.2	96	24	10.4	1040	5500	≈450
	ND1.0-3		1.0					46.2	192	48	20.8			
	ND0.5-3L	0.5	20.6					80	19.9	9.6	1150			
	ND1.0-3L	1.0	41.4					159	39.8	19.1				

- Standard Series
- WYT-T
- WYT-TS
- WYT-TF
- WYT-TD
- WYT-TE
- Comfortable Series
- WYT-L
- Freight Elevator Series
- WYT-TD
- WYT-TE
- WYT-V
- WYT-V1S
- High Speed Series
- WYT-J
- WYT-H
- Heavy Load Series
- WYT-V
- WYT-V1S
- Rail Mount Series
- WYT-R
- Belt Machine Series
- WYT-K
- WYT-F
- The Parameter List of Groove

WYT-TE Freight Elevator Version (4t\5t\6t)

Parameter of Traction Machine

Voltage: AC380V
 Roping: 4 : 1
 Wrap: Single
 Capacity: 4000kg ~ 6000kg
 Speed: 0.5m/s ~ 1.0m/s
 Protection Grade: IP41
 Ins. Class: F
 Traction machine pole: 30
 Stars per hour: 120
 Rating: S5-40%



Parameter of Brake

Model: BLB Ins.Class: F Voltage: DC110V
 Current:

Capacity	Current
4000kg φ 400	1.6A
4000kg φ 480, ≥5000kg	1.98A

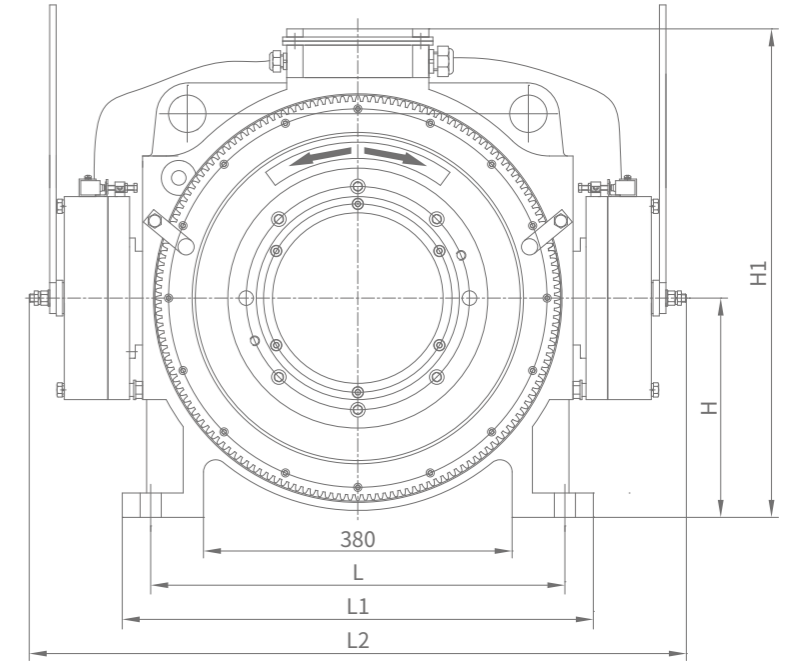
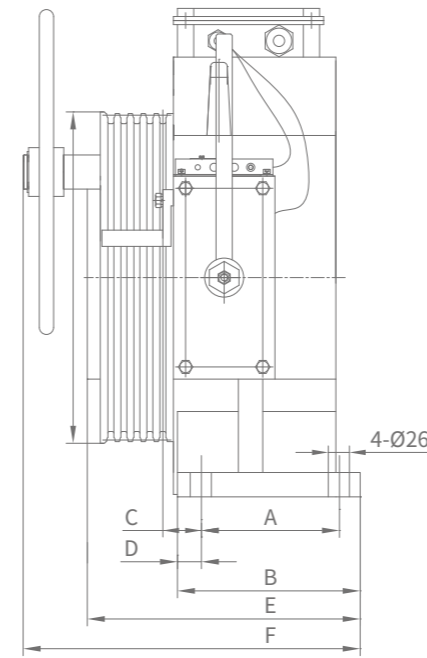

Outline drawing

WYT-TE Freight Elevator Version(4t\5t\6t)

Height: ≤45m

Series	Type	Capacity (kg)	Speed (m/s)	Sheave (mm)	Num	(mm)	Pitch (mm)	Current (A)	Motor Speed (rpm)	Frequency (Hz)	Power (kW)	Torque (Nm)	Shaft Load (kg)	Weight (kg)	Dimension(mm)											
															A	B	C	D	E	F	H	H1	L	L1	L2	
WYT-T	NE0.5-4	4000	0.5	φ 400	9	φ 10	16	29	96	24	13.1	1310	6500	≈680	170	250	59	40	435	505	330	723	560	630	945	
	NE1.0-4		1.0					57.8	192	48	26.2															
	NE0.5-4L	4000	0.5	φ 480	7	φ 12	18	29	80	19.9	13.1	1570	7500	≈750	170	275	59	40	460	530	330	723	560	630	945	
	NE1.0-4L		1.0					57.8	159	39.8	26.2															
	NE0.5-5	5000	0.5	φ 400	9	φ 10	16	37.7	96	24	16.4	1635	7500	≈750	170	275	59	40	460	530	330	723	560	630	945	
	NE1.0-5		1.0					75.3	192	48	32.9															
	NE0.5-5L	5000	0.5	φ 480	7	φ 12	18	36.8	80	19.9	16	1910	7500	≈750	170	275	59	40	460	530	330	723	560	630	945	
	NE1.0-5L		1.0					72.8	159	39.8	31.8															
	NE0.5-6	6000	0.5	φ 400	9	φ 10	16	43	96	24	19.2	1910	7500	≈750	170	275	59	40	460	530	330	723	560	630	945	
	NE1.0-6		1.0					86.7	192	48	38.4															
	NE0.5-6L	6000	0.5	φ 480	7	φ 12	18	42.0	80	19.9	18.4	2200	7500	≈750	170	275	59	40	460	530	330	723	560	630	945	
	NE1.0-6L		1.0					83.2	159	39.8	36.6															

Standard Series
 WYT-T
 WYT-TS
 WYT-TF
 WYT-TD
 WYT-TE

Comfortable Series
 WYT-L

Freight Elevator Series
 WYT-TD
WYT-TE
 WYT-V
 WYT-V1S

High Speed Series
 WYT-J
 WYT-H

Heavy Load Series
 WYT-V
 WYT-V1S

Rail Mount Series
 WYT-R

Belt Machine Series
 WYT-K
 WYT-F

The Parameter List of Groove

WYT-V Freight Elevator Version (6t)

Parameter of Traction Machine

Voltage: AC380V
 Roping: 4 : 1
 Wrap: Single
 Capacity: 6000kg
 Speed: 0.5m/s ~ 1.0m/s
 Protection Grade: IP41
 Ins. Class: F
 Traction machine pole: 30
 Stars per hour: 120
 Rating: S5-40%



Parameter of Brake

Model: BLB Ins.Class: F Voltage: DC110V Current: 1.98A

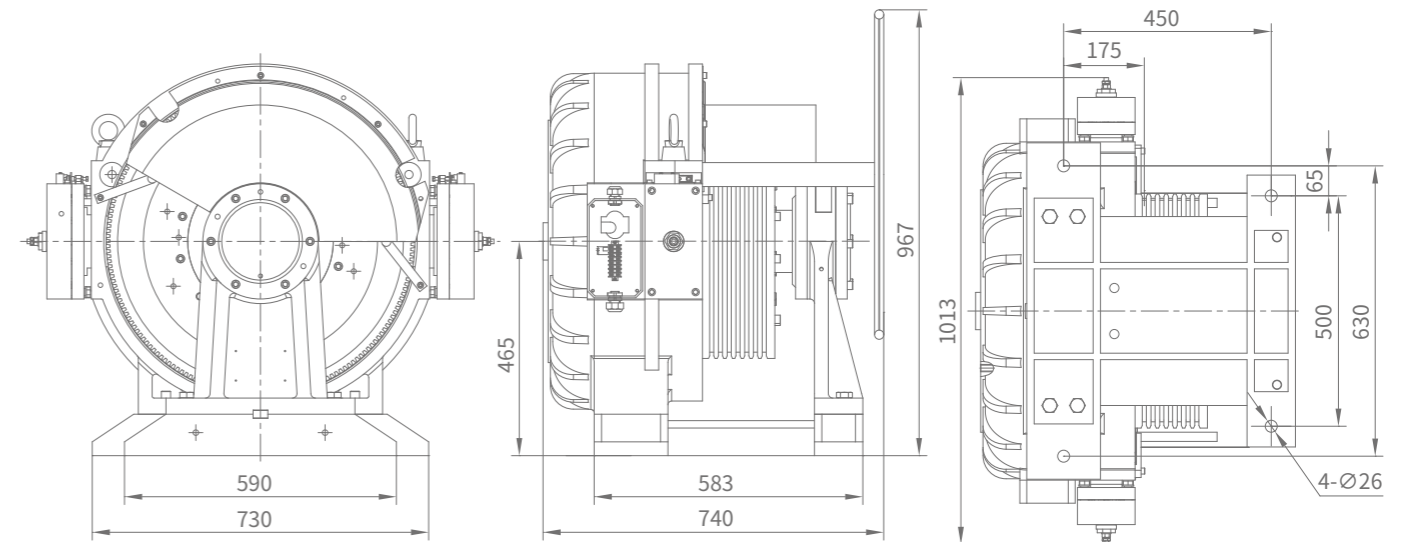

Outline drawing

WYT-V Freight Elevator Version (6t)

Height: ≤45m

Series	Type	Capacity (kg)	Speed (m/s)	Sheave (mm)	Num	(mm)	Pitch (mm)	Current (A)	Motor Speed (rpm)	Frequency (Hz)	Power (kW)	Torque (Nm)	Shaft Load (kg)	Weight (kg)
WYT-V	0.5-6	6000	0.5	φ480	9	φ12	18	43.6	80	19.9	19.2	2286	10000	≈1000
	1.0-6		1.0					85.8	159	39.8	38.1			

- Standard Series
- WYT-T
- WYT-TS
- WYT-TF
- WYT-TD
- WYT-TE
- Comfortable Series
- WYT-L
- Freight Elevator Series
- WYT-TD
- WYT-TE
- WYT-V**
- WYT-VIS
- High Speed Series
- WYT-J
- WYT-H
- Heavy Load Series
- WYT-V
- WYT-VIS
- Rail Mount Series
- WYT-R
- Belt Machine Series
- WYT-K
- WYT-F
- The Parameter List of Groove

WYT-V1S Freight Elevator Version (8t\10t)

Parameter of Traction Machine

Voltage: AC380V
 Roping: 4 : 1
 Wrap: Single
 Capacity: 8000kg ~ 10000kg
 Speed: 0.5m/s ~ 1.0m/s
 Protection Grade: IP41
 Ins. Class: F
 Traction machine pole: 30
 Stars per hour: 120
 Rating: S5-40%



Parameter of Brake

Model: BLB Ins.Class: F
 Voltage: DC110V Current: 1.98A

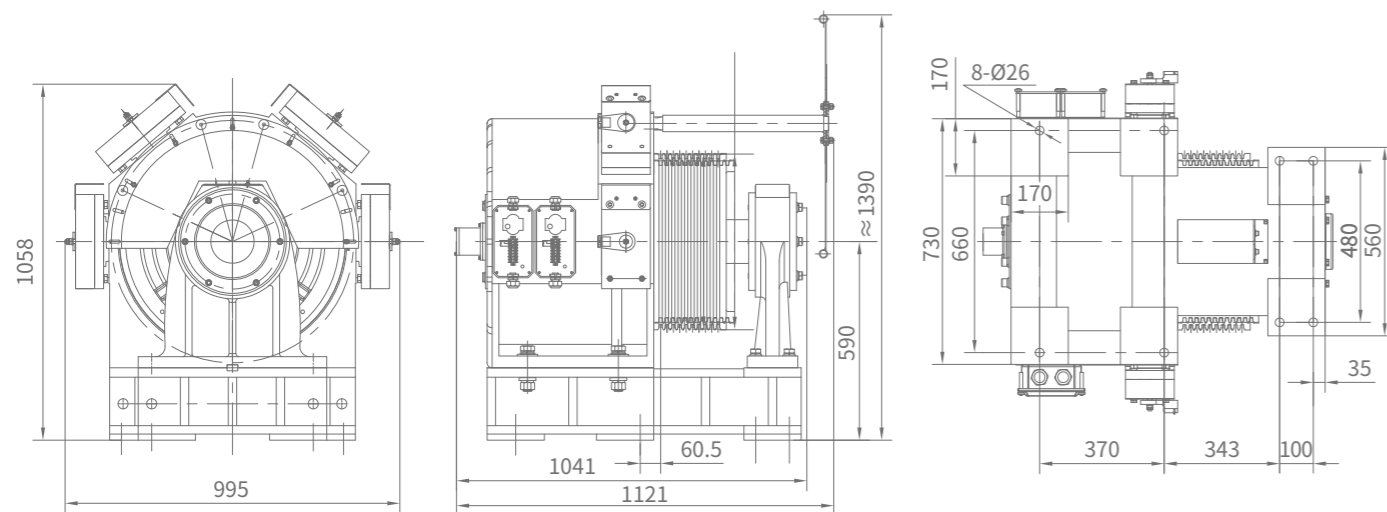

Outline drawing

WYT-V1S Freight Elevator Version (8t\10t)

Height: ≤45m

Series	Type	Capacity (kg)	Speed (m/s)	Sheave (mm)	Num	(mm)	Pitch (mm)	Current (A)	Motor Speed (rpm)	Frequency (Hz)	Power (kW)	Torque (Nm)	Shaft Load (kg)	Weight (kg)
WYT-V1S	C0.5-8	8000	0.5	φ480	12	φ12	18	54.6	80	19.9	26.1	3120	15000	≈2500
	C1.0-8		1.0					109.0	159	39.8	51.9			
	C0.5-8L	0.5	φ520	10	φ13	19	54.6	73	18.3	25.8	3380			
	C1.0-8L	1.0					109.0	147	36.7	52.0				
WYT-V1S	C0.5-10	10000	0.5	φ480	12	φ12	18	67.5	80	19.9	32.7	3900	15000	≈2500
	C1.0-10		1.0					136.0	159	39.8	64.9			
	C0.5-10L	0.5	φ520	10	φ13	19	67.5	73	18.3	32.3	4225			
	C1.0-10L	1.0					136.0	147	36.7	65.0				

Recommended single groove V

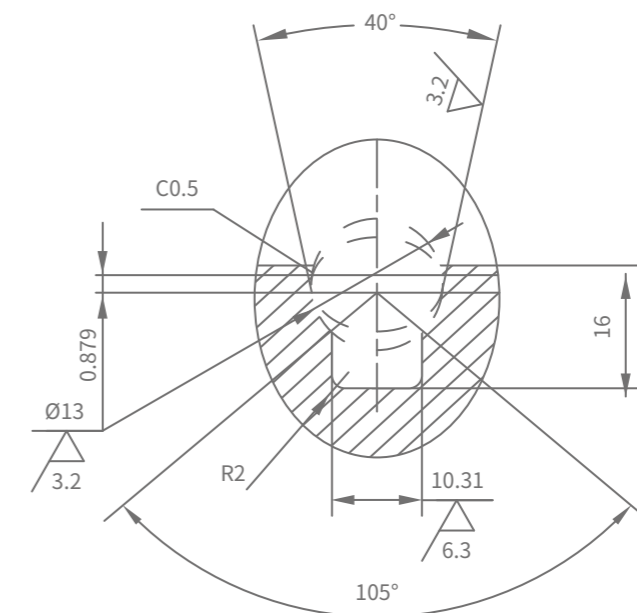

Outline drawing

Standard Series
 WYT-T
 WYT-TS
 WYT-TF
 WYT-TD
 WYT-TE

Comfortable Series
 WYT-L

Freight Elevator Series
 WYT-TD
 WYT-TE
 WYT-V
 WYT-V1S

High Speed Series
 WYT-J
 WYT-H

Heavy Load Series
 WYT-V
 WYT-V1S

Rail Mount Series
 WYT-R

Belt Machine Series
 WYT-K
 WYT-F

The Parameter List of Groove

WYT - J / H HIGH SPEED SERIES

WYT-J Double Wrap Version



WYT-J series products are developed with large torque and heavy load capacity by Bluelight in 2020. It is widely used in high-rise buildings elevator applications such as panorama elevator, passenger & cargo elevator, hospital bed elevator and else.

Parameter of Traction Machine

Voltage: AC380V
 Roping: 2 : 1
 Wrap: Double
 Capacity: 800kg ~ 2000kg
 Speed: 1.0m/s ~ 4.0m/s
 Protection Grade: IP41
 Ins. Class: F
 Traction machine pole: 30
 Stars per hour: 240
 Rating: S5-40%

Parameter of Brake

Model: BLB Ins.Class: F Voltage: DC110V Current: 1.98A

Features

- Double support design, reliable mechanical structure with high shaft load and high speed;
- High torque density with high efficiency;
- Optimized design for winding, lower harmonics, lower noise, low vibration, smooth running;
- Advanced heat dissipation design, low temperature rise;
- Use block type armless brake, simple structure with fast response time and high reliability.

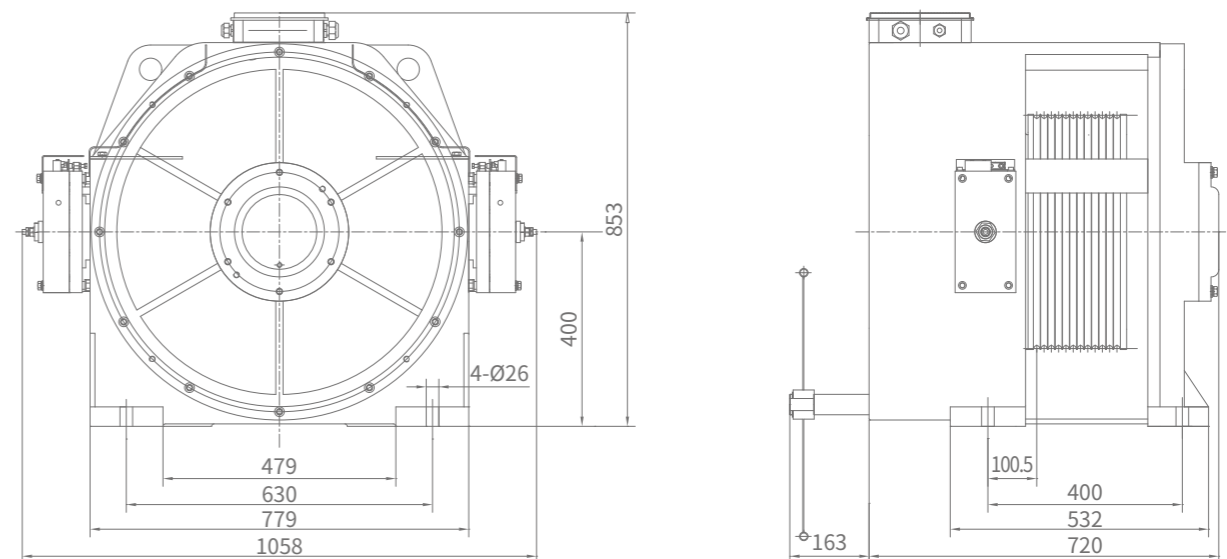

Outline drawing

WYT-J Double Wrap Version

Height: ≤180m

Series	Type	Capacity (kg)	Speed (m/s)	Sheave (mm)	Num	(mm)	Pitch (mm)	Current (A)	Motor Speed (rpm)	Frequency (Hz)	Power (kW)	Torque (Nm)	Shaft Load (kg)	Weight (kg)
WYT-J	1.0A2	800	1.0	φ480	8	φ10	14	14	80	20	5.7	682	14000	≈1200
	1.6A2		1.6					20.8	127	31.8	9.1			
	1.75A2		1.75					22.9	139	34.8	9.9			
	2.0A2		2.0					25.5	159	39.8	11.4			
	2.5A2		2.5					31.5	199	49.7	14.2			
	3.0A2		3.0					37.3	239	59.8	17.1			
	4.0A2	4.0	49.1	318	79.5	22.7								
	1.0B2	1000	1.0	φ480	10	φ10	14	16.1	80	20	6.8	810	14000	≈1200
	1.6B2		1.6					24.5	127	31.8	10.8			
	1.75B2		1.75					26.3	139	34.8	11.8			
	2.0B2		2.0					29.6	159	39.8	13.5			
	2.5B2		2.5					37.5	199	49.7	16.9			
	3.0B2		3.0					44.4	239	59.8	20.3			
	4.0B2	4.0	58.6	318	79.5	27.0								
	1.0C2	1275	1.0	φ480	10	φ12	15	22.4	80	20	8.5	1020	14000	≈1200
	1.6C2		1.6					33.6	127	31.8	13.6			
	1.75C2		1.75					36.5	139	34.8	14.8			
	2.0C2		2.0					41.5	159	39.8	17			
	2.5C2		2.5					51.4	199	49.7	21.3			
	3.0C2		3.0					60.3	239	59.8	25.5			
	4.0C2	4.0	79.5	318	79.5	34								
	1.0D2	1350	1.0	φ480	10	φ12	15	25	80	20	9.5	1140	14000	≈1200
	1.6D2		1.6					37.6	127	31.8	15.2			
	1.75D2		1.75					40.8	139	34.8	16.6			
2.0D2	2.0		46.4					159	39.8	19				
2.5D2	2.5		57.4					199	49.7	23.8				
3.0D2	3.0		67.4					239	59.8	28.5				
4.0D2	4.0	89	318	79.5	38									
1.0E2	1600	1.0	φ480	10	φ12	15	27	80	20	11.1	1330	14000	≈1200	
1.6E2		1.6					41	127	31.8	17.7				
1.75E2		1.75					45.8	139	34.8	19.4				
2.0E2		2.0					51	159	39.8	22.2				
2.5E2		2.5					63.8	199	49.7	27.7				
3.0E2		3.0					74.6	239	59.8	33.3				
4.0E2	4.0	99.6	318	79.5	44.3									
1.0EF2	1800	1.0	φ480	12	φ12	15	29.7	80	20	12.5	1490	14000	≈1200	
1.6EF2		1.6					45.8	127	31.8	19.8				
1.75EF2		1.75					49.6	139	34.8	21.7				
2.0EF2		2.0					55.8	159	39.8	24.8				
2.5EF2		2.5					71.5	199	49.7	31				
3.0EF2		3.0					85.2	239	59.8	37.3				
4.0EF2	4.0	112	318	79.5	49.6									
1.0F2	2000	1.0	φ480	12	φ12	15	34	80	20	13.8	1650	14000	≈1200	
1.6F2		1.6					53	127	31.8	22				
1.75F2		1.75					54.9	139	34.8	24				
2.0F2		2.0					63.5	159	39.8	27.5				
2.5F2		2.5					80	199	49.7	34.4				
3.0F2		3.0					92	239	59.8	41.3				
4.0F2	4.0	115	318	79.5	54.9									

Standard Series
WYT-T
WYT-TS
WYT-TF
WYT-TD
WYT-TE

Comfortable Series
WYT-L

Freight Elevator Series

WYT-TD
WYT-TE
WYT-V
WYT-VIS

High Speed Series
WYT-J
WYT-H

Heavy Load Series
WYT-V
WYT-VIS

Rail Mount Series
WYT-R

Belt Machine Series
WYT-K
WYT-F

The Parameter List of Groove

WYT-H Ultra-high Speed Version

WYT-H series ultra-high speed PM gearless traction machine is developed by Bluelight in 2012 to target skyscrapers with ultra-high speed elevator (up to 8m/s).

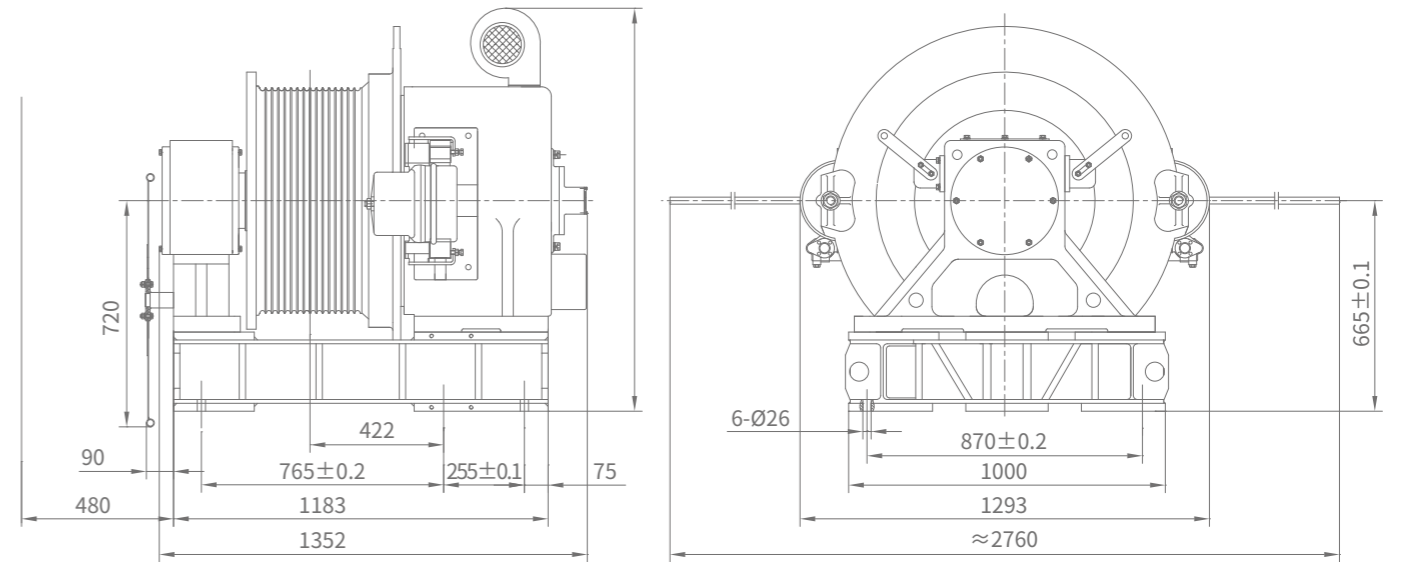

Outline drawing

Parameter of Traction Machine

Voltage: AC380V
 Roping: 1 : 1
 Wrap: Double
 Capacity: 1600kg
 Speed: 5m/s ~ 8m/s
 Protection Grade: IP41
 Ins. Class: H
 Traction machine pole: 30
 Stars per hour: 240
 Rating: S5-40%

Features

- ◎ Extra high shaft load design, suitable for ultra-high speed operation;
- ◎ Optimized winding design, less harmonic content, loss distribution optimization, fan cooling system with low temperature rise;
- ◎ Use SUNTES disk brake system, high reliability.

Parameter of Brake

Model: EC-4026EF-100 Ins.Class: F Voltage: DC90V/40V Current: 4.7/2.1A

WYT-H Ultra-high Speed Version

Height: ≤360m

Series	Type	Capacity (kg)	Speed (m/s)	Sheave (mm)	Num	(mm)	Pitch (mm)	Current (A)	Motor Speed (rpm)	Frequency (Hz)	Power (kW)	Torque (Nm)	Shaft Load (kg)	Weight (kg)
WYT-H	5.0E1	1600	5.0	φ 710	16	φ 16	20	111.4	134	33.6	51	3626	35000	≈3500
	6.0E1		135.3					161	40.3	61.2				
	7.0E1		158					188	47.1	71.5				
	8.0E1		172.7					215	53.8	81.7				

WYT - V / V1S

HEAVY LOAD SERIES

WYT-V series PMS machine is developed for high rise factory plant cargo lift, it uses latest Permanent magnetic motor technology, optimised electromagnetic & mechanical design with excellent operation performance.

WYT-V



Parameter of Traction Machine

- Voltage: AC380V
- Roping: 1 : 1
- Wrap: Single
- Capacity: 1000kg ~ 1500kg
- Speed: 1.0m/s ~ 4.0m/s
- Protection Grade: IP41
- Ins. Class: F
- Traction machine pole: 30
- Stars per hour: 240
- Rating: S5-40%

Parameter of Brake

- Model: BLB
- Ins.Class: F
- Voltage: DC110V
- Current: 1.98A

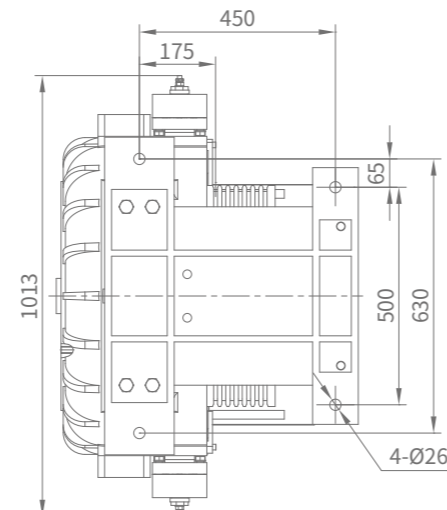
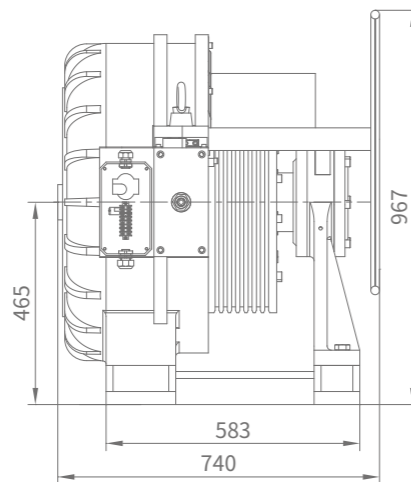
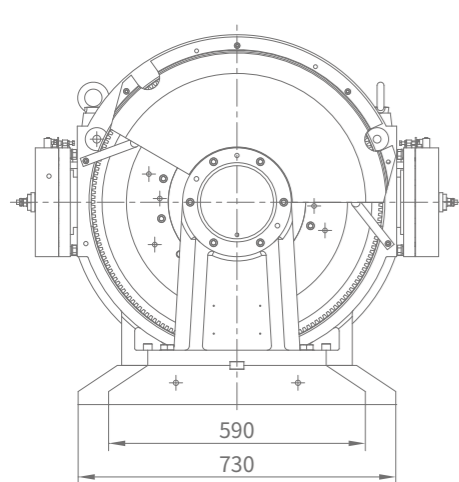

Outline drawing

WYT-V Heavy Load (1:1)

Height: ≤120m

Series	Type	Capacity (kg)	Speed (m/s)	Sheave (mm)	Num	(mm)	Pitch (mm)	Current (A)	Motor Speed (rpm)	Frequency (Hz)	Power (kW)	Torque (Nm)	Shaft Load (kg)	Weight (kg)
WYT-V	1.0BS48	1000	1.0	φ 480	10	φ 10	16	14.8	40	9.95	6.6	1570	10000	≈1000
	1.5BS48		1.5					21.8	60	15	9.9			
	1.75BS48		1.75					25.3	70	17.5	11.5			
	2.0BS48		2.0					28.7	80	19.9	13.1			
	2.5BS48		2.5					37	100	25	16.4			
	3.0BS48		3.0					44.2	119	29.8	19.6			
	4.0BS48	4.0	59	159	39.8	26.1								
	1.0BS50	1000	1.0	φ 500	7	φ 12	19	14.8	38	9.5	6.6	1640		
	1.5BS50		1.5					21.8	57	14.3	9.9			
	1.75BS50		1.75					25.3	67	16.7	11.5			
	2.0BS50		2.0					28.7	76	19	13.1			
	2.5BS50		2.5					37	96	24	16.4			
	3.0BS50		3.0					44.2	115	28.7	19.7			
	4.0BS50	4.0	59	153	38.2	26.3								
	1.0BCS48	1150	1.0	φ 480	10	φ 10	16	17	40	9.95	7.5	1800		
	1.5BCS48		1.5					25.2	60	15	11.3			
	1.75BCS48		1.75					29.4	70	17.5	13.2			
	2.0BCS48		2.0					33.3	80	19.9	15			
	2.5BCS48		2.5					41.8	100	25	18.8			
	3.0BCS48		3.0					50	119	29.8	22.4			
	4.0BCS48	4.0	66.7	159	39.8	30								
	1.0BCS50	1150	1.0	φ 500	7	φ 12	19	17	38	9.5	7.5	1880		
	1.5BCS50		1.5					25.2	57	14.3	11.3			
	1.75BCS50		1.75					29.4	67	16.7	13.2			
	2.0BCS50		2.0					33.3	76	19	15			
	2.5BCS50		2.5					41.8	96	24	18.8			
	3.0BCS50		3.0					50	115	28.7	22.6			
	4.0BCS50	4.0	66.7	153	38.2	30.1								
	1.0CS48	1250	1.0	φ 480	10	φ 10	16	19	40	9.95	8	1940		
	1.5CS48		1.5					27.8	60	15	12.1			
	1.75CS48		1.75					32	70	17.5	14.2			
	2.0CS48		2.0					36.6	80	19.9	16.1			
	2.5CS48		2.5					45.5	100	25	20.3			
	3.0CS48		3.0					54.8	119	29.8	24.2			
	4.0CS48	4.0	73	159	39.8	32.3								
	1.0CS50	1250	1.0	φ 500	7	φ 12	19	19	38	9.5	8	2020		
	1.5CS50		1.5					27.8	57	14.3	12.1			
	1.75CS50		1.75					32	67	16.7	14.2			
	2.0CS50		2.0					36.6	76	19	16.1			
	2.5CS50		2.5					45.5	96	24	20.3			
3.0CS50	3.0		54.8					115	28.7	24.3				
4.0CS50	4.0	73	153	38.2	32.4									
1.0DES48	1500	1.0	φ 480	9	φ 12	18	22.8	40	9.95	9.6	2286			
1.5DES48		1.5					32.7	60	15	14.4				
1.75DES48		1.75					38.2	70	17.5	16.8				
2.0DES48		2.0					43.6	80	19.9	19.2				
2.5DES48		2.5					54.3	100	25	23.9				
3.0DES48		3.0					64	119	29.8	28.5				
4.0DES48	4.0	85.8	159	39.8	38.1									

- Standard Series
- WYT-T
- WYT-TS
- WYT-TF
- WYT-TD
- WYT-TE
- Comfortable Series
- WYT-L
- Freight Elevator Series
- WYT-TD
- WYT-TE
- WYT-V
- WYT-V1S
- High Speed Series
- WYT-J
- WYT-H
- Heavy Load Series
- WYT-V
- WYT-V1S
- Rail Mount Series
- WYT-R
- Belt Machine Series
- WYT-K
- WYT-F
- The Parameter List of Groove

WYT-V1S

Parameter of Traction Machine

Voltage: AC380V
 Suspension: 1 : 1
 Rope: Single
 Capacity: 1500kg ~ 2500kg
 Speed: 1.0m/s ~ 4.0m/s

Prot. Class: IP41
 Ins. Class: F
 Traction machine pole: 30
 Stars per hour: 240
 Rating: S5-40%



Features

- Double support structure, reliable structure, better performance;
- High load, high efficiency, high torque density;
- The machine runs smoothly, low vibration;
- The heat dissipation design of the machine is good, and the low temperature rises.

Parameter of Brake

Model: BLB Ins. Class: F Voltage: DC110V Current: 1.98A

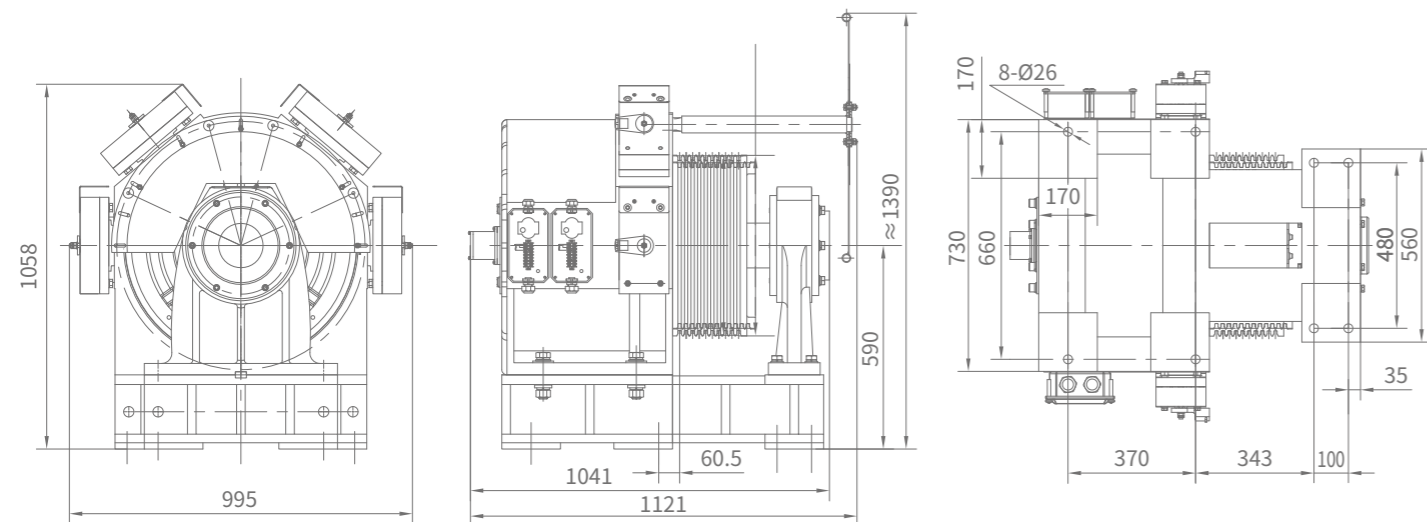

Outline drawing

WYT-V1S Heavy Load (1:1)

Height: ≤120m

Series	Type	Capacity (kg)	Speed (m/s)	Sheave (mm)	Num	(mm)	Pitch (mm)	Current (A)	Motor Speed (rpm)	Frequency (Hz)	Power (kW)	Torque (Nm)	Shaft Load (kg)	Weight (kg)		
WYT-V1S	C1.0DE	1500	1.0	φ 480	12	φ 12	18	22.8	40	9.95	9.6	2286	15000	≈2500		
	C1.75DE		1.75					38.2	70	17.5	16.8					
	C2.0DE		2.0					43.6	80	19.9	19.2					
	C3.0DE		3.0					64	119	29.8	28.5					
	C4.0DE	4.0	85.8	159	39.8	38.1										
	C1.0DEL	1500	1.0	φ 520	10	φ 13	19	22.8	37	9.3	9.6	2476				
	C1.75DEL		1.75					38.2	64	16	16.6					
	C2.0DEL		2.0					43.6	73	18.3	18.9					
	C3.0DEL		3.0					64	110	27.5	28.5					
	C4.0DEL	4.0	85.8	147	36.7	38.1										
	C1.0F	2000	1.0	φ 480	12	φ 12	18	27.5	40	9.95	13.1	3120				
	C1.75F		1.75					48.0	70	17.5	22.9					
C2.0F	2.0		54.6					80	19.9	26.1						
C3.0F	3.0		81.8					119	29.8	38.9						
C4.0F	4.0	109.0	159	39.8	51.9											
C1.0FL	2000	1.0	φ 520	10	φ 13	19	27.5	37	9.3	13.1	3380					
C1.75FL		1.75					48.0	64	16	22.7						
C2.0FL		2.0					54.6	73	18.3	25.8						
C3.0FL		3.0					81.8	110	27.5	38.9						
C4.0FL	4.0	109.0	147	36.7	52.0											
C1.0G	2500	1.0	φ 480	12	φ 12	18	34.7	40	9.95	16.3	3900					
C1.75G		1.75					60.4	70	17.5	28.6						
C2.0G		2.0					67.5	80	19.9	32.7						
C3.0G		3.0					102.0	119	29.8	48.6						
C4.0G	4.0	136.0	159	39.8	64.9											
C1.0GL	2500	1.0	φ 520	10	φ 13	19	34.7	37	9.3	16.4	4225					
C1.75GL		1.75					60.4	64	16	28.3						
C2.0GL		2.0					67.5	73	18.3	32.3						
C3.0GL		3.0					102.0	110	27.5	48.7						
C4.0GL	4.0	136.0	147	36.7	65.0											

Recommended single groove V

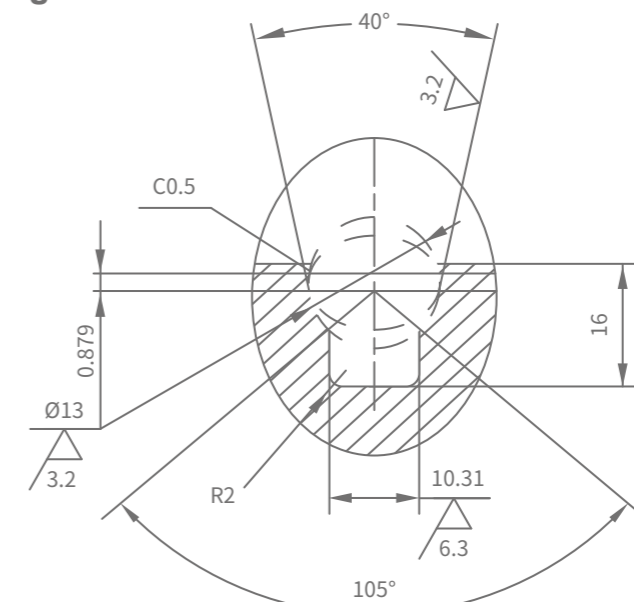

Outline drawing

WYT - R RAIL MOUNT SERIES

WYT-R Rail Mount Version

WYT-R series products are the new generation outer rotor structure PM gearless traction machine developed by Bluelight in 2023. It is suitable for rail mount application.

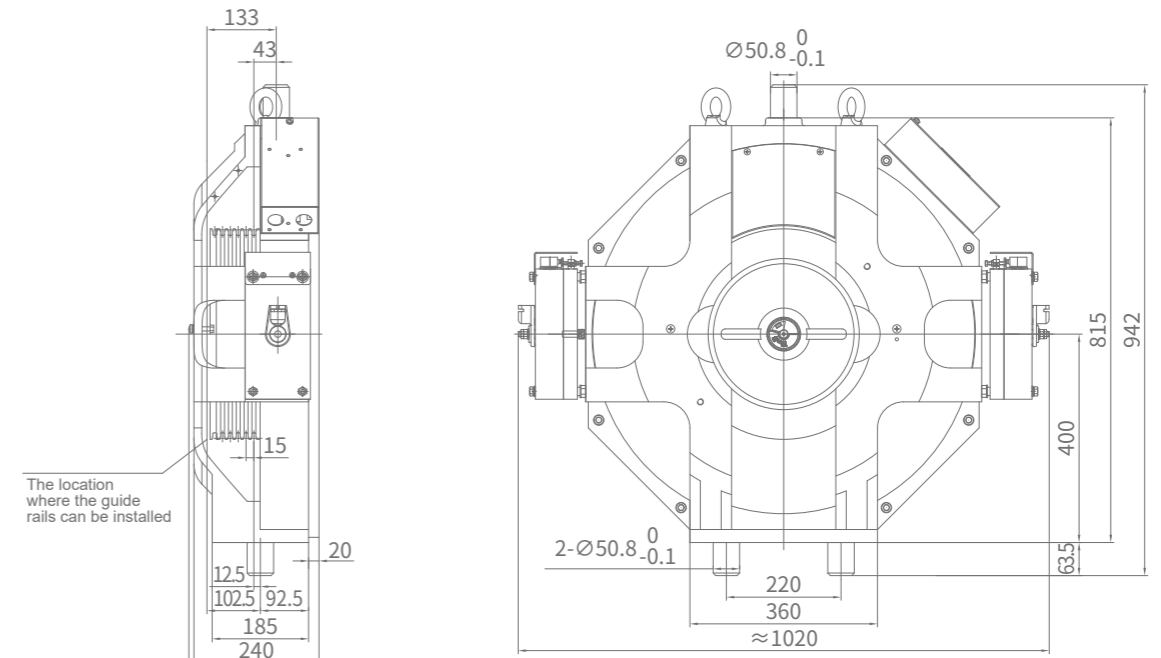
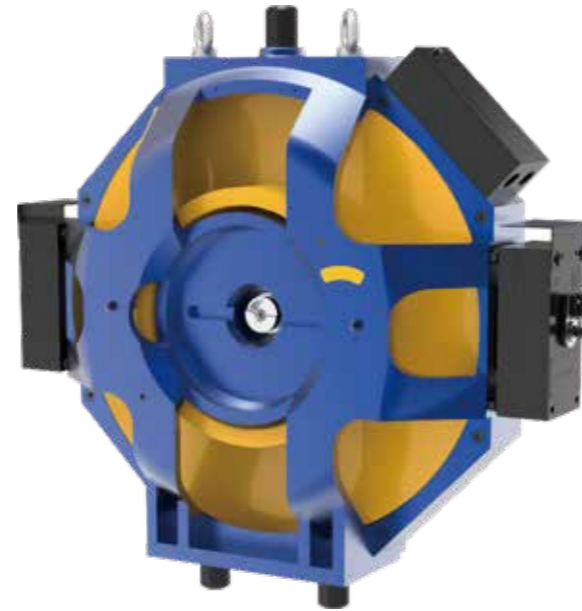

Outline drawing

Parameter of Traction Machine

Voltage: AC380V
 Roping: 2 : 1
 Wrap: Single
 Capacity: 630kg ~ 1150kg
 Speed: 1.0m/s ~ 2.0m/s
 Protection Grade: IP41
 Ins. Class: F
 Traction machine pole: 30
 Stars per hour: 240
 Rating: S5-40%

Features

- ◎ Special design for rail mount.
- ◎ Further improves heat dissipation.
- ◎ The outer rotor structure improves electromagnetic structure, result smooth low speed running and high overload capacity.
- ◎ Use block type armless brake, it has fast response time & high reliability.

Parameter of Brake

Model: BLB Ins.Class: F Voltage: DC110V
 Current:

Capacity	Current
630kg	1.1A
800kg ~ 1150kg	1.3A

WYT-R Rail Mount Series

Height: ≤90m

Series	Type	Capacity (kg)	Speed (m/s)	Sheave (mm)	Num	(mm)	Pitch (mm)	Current (A)	Motor Speed (rpm)	Frequency (Hz)	Power (kW)	Torque (Nm)	Shaft Load (kg)	Weight (kg)
WYT-R	CN1.0B	630	1.0	∅ 400	4	∅ 10	15	10.4	96	24	4.6	460	4000	≈450
	CN1.5B		1.5					16.7	144	36	6.9			
	CN1.6B		1.6					17.1	153	38.3	7.4			
	CN1.75B		1.75					17.8	168	42	8.1			
	CN2.0B		2.0					20.2	192	48	9.3			
	CN1.0C	800	1.0	∅ 400	5	∅ 10	15	12	96	24	5.2	520		
	CN1.5C		1.5					20.0	144	36	7.8			
	CN1.6C		1.6					20.4	153	38.3	8.3			
	CN1.75C		1.75					20.7	168	42	9.1			
	CN2.0C		2.0					23.0	192	48	10.5			
	CN1.0D	1000	1.0	∅ 400	5	∅ 10	15	13.8	96	24	6.1	605		
	CN1.5D		1.5					25	144	36	10			
	CN1.6D		1.6					25.5	153	38.3	10.7			
	CN1.75D		1.75					26.2	168	42	11.7			
	CN2.0D		2.0					29.8	192	48	13.4			
	CN1.0E	1150	1.0	∅ 400	5	∅ 10	15	17.2	96	24	7.7	765		
	CN1.5E		1.5					28.3	144	36	11.5			
	CN1.6E		1.6					28.7	153	38.3	12.3			
	CN1.75E		1.75					29.5	168	42	13.4			
	CN2.0E		2.0					33	192	48	15.4			

- Standard Series
- WYT-T
- WYT-TS
- WYT-TF
- WYT-TD
- WYT-TE
- Comfortable Series
- WYT-L
- Freight Elevator Series
- WYT-TD
- WYT-TE
- WYT-V
- WYT-VIS
- High Speed Series
- WYT-J
- WYT-H
- Heavy Load Series
- WYT-V
- WYT-VIS
- Rail Mount Series
- WYT-R
- Belt Machine Series
- WYT-K
- WYT-F
- The Parameter List of Groove

WYT - K / F BELT MACHINE SERIES

WYT-K Commercial Elevator Version

Due to increase needs of belt elevator, Bluelight group develop WYT-K series belt drive PMS machine. The belt machine can work with Bluelight belt (STD 43) to achieve best lift comfort level with minimum operation noise. This series machine has small size suitable for MRL design and easy maintenance.

Parameter of Traction Machine

Voltage: AC380V
 Roping: 2 : 1
 Wrap: Single
 Capacity: 630kg ~ 1600kg
 Speed: 1.0m/s ~ 2.0m/s
 Protection Grade: IP41
 Ins. Class: F
 Traction machine pole: 20
 Stars per hour: 240
 Rating: S5-40%

Parameter of Brake

Model: BLS
 Ins.Class: F
 Voltage: DC110V
 Current: 1.5A×2



Features

- Double support structure, reliable structure, better performance;
- Configured with shaft brake of low noise and compact structure;
- Use self-sealed bearings, maintenance-free;
- Electromagnetic structure optimization, smooth running and low noise.

WYT-K Series (630kg-1000kg)

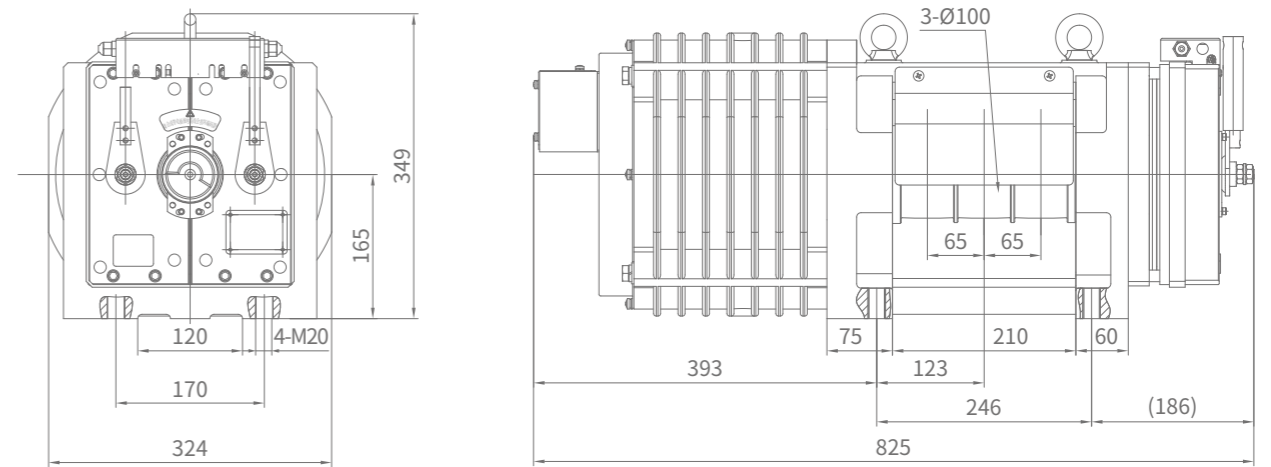

630kg-1000kg Outline drawing

WYT-K Series (1150kg-1600kg)

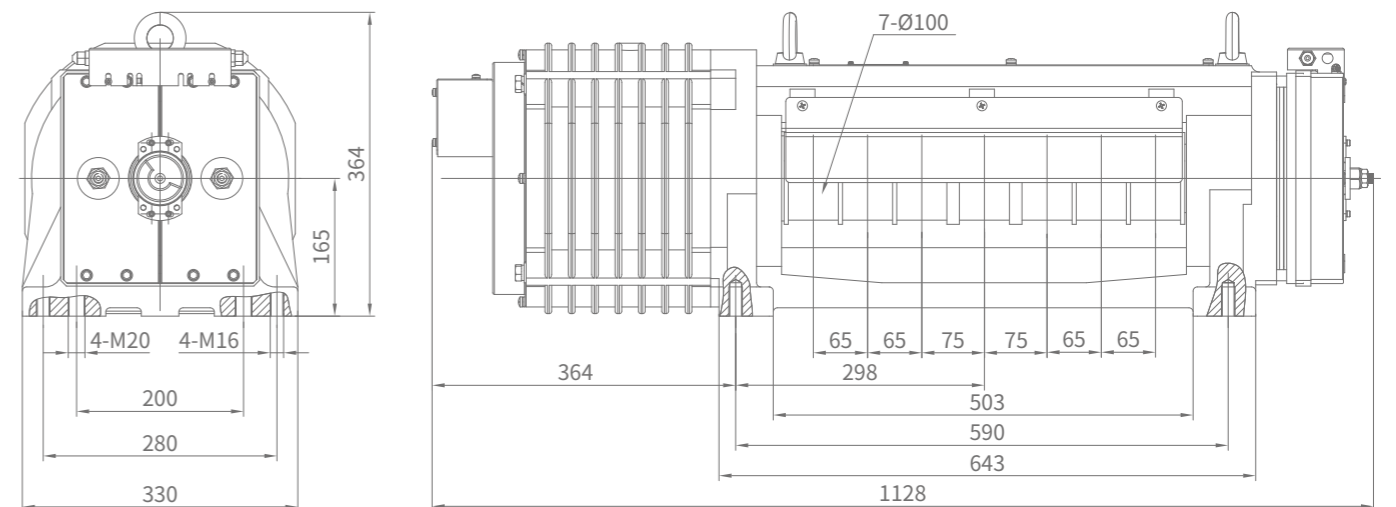

1150kg-1600kg Outline drawing

- Standard Series
- WYT-T
- WYT-TS
- WYT-TF
- WYT-TD
- WYT-TE
- Comfortable Series
- WYT-L
- Freight Elevator Series
- WYT-TD
- WYT-TE
- WYT-V
- WYT-VIS
- High Speed Series
- WYT-J
- WYT-H
- Heavy Load Series
- WYT-V
- WYT-VIS
- Rail Mount Series
- WYT-R
- Belt Machine Series
- WYT-K
- WYT-F
- The Parameter List of Groove

WYT-K Commercial Elevator Version

Series	Type	Capacity (kg)	Speed (m/s)	Sheave (mm)	Num	(mm)	Pitch (mm)	Current (A)	Motor Speed (rpm)	Frequency (Hz)	Power (kW)	Torque (Nm)	Shaft Load (kg)	Weight (kg)
WYT-K	1.0B	630	1.0	φ 100	3	60	65	9.7	382	63.7	4.2	105	2000	≈220
	1.5B		1.5					16.6	573	95.5	6.3			
	1.6B		1.6					16.8	611	101.9	6.7			
	1.75B		1.75					17	668	111.4	7.3			
	2.0B		2.0					19.3	764	127.3	8.4			
	1.0C	800	1.0	φ 100	3	60	65	12.2	382	63.7	5.2	130	2000	≈220
	1.5C		1.5					20.6	573	95.5	7.8			
	1.6C		1.6					20.8	611	101.9	8.3			
	1.75C		1.75					21	668	111.4	9.1			
	2.0C		2.0					23.8	764	127.3	10.4			
	1.0D	1000	1.0	φ 100	3	60	65	15.4	382	63.7	6.8	170	2000	≈220
	1.5D		1.5					26.5	573	95.5	10.2			
	1.6D		1.6					26.6	611	101.9	10.9			
	1.75D		1.75					26.8	668	111.4	11.9			
	2.0D		2.0					30.6	764	127.3	13.6			
	1.0E	1150	1.0	φ 100	7	60	65	17.3	382	63.7	7.6	190	4200	≈320
	1.5E		1.5					29.6	573	95.5	11.4			
	1.6E		1.6					29.8	611	101.9	12.2			
	1.75E		1.75					30	668	111.4	13.3			
	2.0E		2.0					34.2	764	127.3	15.2			
	1.0F	1275	1.0	φ 100	7	60	65	18.8	382	63.7	8.4	210	4200	≈320
	1.5F		1.5					32.4	573	95.5	12.6			
	1.6F		1.6					32.6	611	101.9	13.4			
	1.75F		1.75					32.8	668	111.4	14.7			
2.0F	2.0		37.4					764	127.3	16.8				
1.0G	1350	1.0	φ 100	7	60	65	19.8	382	63.7	8.8	220	4200	≈320	
1.5G		1.5					34.2	573	95.5	13.2				
1.6G		1.6					34.4	611	101.9	14.1				
1.75G		1.75					34.6	668	111.4	15.4				
2.0G		2.0					39.4	764	127.3	17.6				
1.0H	1600	1.0	φ 100	7	60	65	23.8	382	63.7	10.6	265	4200	≈320	
1.5H		1.5					41.2	573	95.5	15.9				
1.6H		1.6					41.4	611	101.9	17.0				
1.75H		1.75					41.6	668	111.4	18.5				
2.0H		2.0					47.5	764	127.3	21.2				

WYT-F Home Elevator Version

Due to increase needs of home (belt villa) elevator, Bluelight group develop WYT-F series belt drive PMS machine. The belt machine can work with Bluelight belt (STD 43) to achieve best lift comfort level with minimum operation noise. This series machine has small size suitable for MRL design and easy maintenance.



Parameter of Traction Machine

Voltage: AC380V/AC220V
 Roping: 2 : 1
 Wrap: Single
 Capacity: 450kg
 Wheel Diameter: Φ100
 Speed: 0.4m/s ~ 1.0m/s
 Protection Grade: IP41
 Ins. Class: F
 Traction machine pole: 20
 Stars per hour: 150
 Rating) : S5-25%

Features

- Machine is made of aluminum alloy material, with good heat dissipation, small size and light weight;
- Configured with shaft brake of low noise and compact structure;
- Adopt two blance full sealed bears, free maintain;
- Smooth running, excellent performance at low speed.

WYT-F Series (2-Wheel Separated)

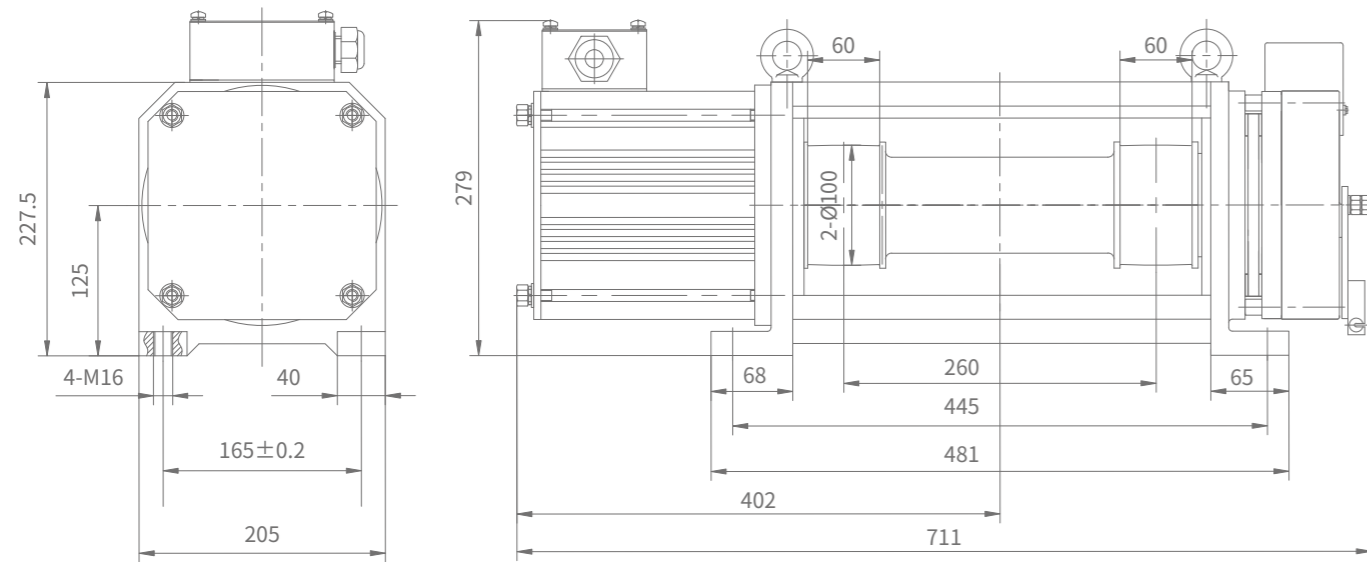

Outline drawing

Technical parameters

Height: ≤20m

Series	Type	Capacity (kg)	Speed (m/s)	Sheave (mm)	Num	Width (mm)	Pitch (mm)	Voltage (v)	Current (A)	Motor Speed (rpm)	Frequency (Hz)	Power (kW)	Torque (Nm)	Shaft Load (kg)	Weight (kg)
WYT-F	E2V0.4B 100/260	450	0.4	φ 100	2	60	260	380	3.3	153	25.5	1.1	70	2000	≈100
								220	5.7						
	E2V1.0B 100/260	1.0	380					6.4	382	63.7	2.8				
			220					11							

WYT-F Series (2-Wheel Parallel)

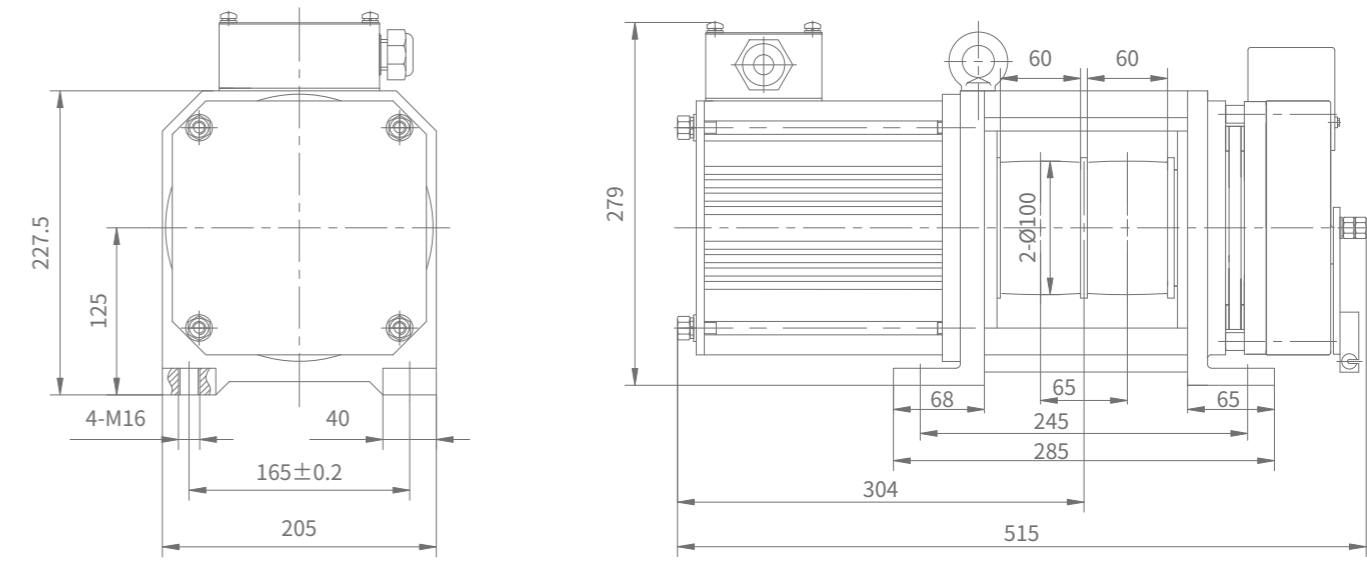

Outline drawing

Technical parameters

Height: ≤20m

Series	Type	Capacity (kg)	Speed (m/s)	Sheave (mm)	Num	Width (mm)	Pitch (mm)	Voltage (v)	Current (A)	Motor Speed (rpm)	Frequency (Hz)	Power (kW)	Torque (Nm)	Shaft Load (kg)	Weight (kg)
WYT-F	E2V0.4B 100/65	450	0.4	φ 100	2	60	65	380	3.3	153	25.5	1.1	70	2000	≈90
								220	5.7						
	E2V1.0B 100/65	1.0	380					6.4	382	63.7	2.8				
			220					11							

ACCESSORIES - BELT

SYLG-EB Hoisting Belt for Elevator

Bluelight has complete production lines from precise galvanized steel rope to elevator traction belt. The annual production capacity of elevator steel belt is 2 million meters. R&D center has invested full sets of testing equipment for elevator traction belt examination and certification, as well supporting product development and customer cooperation.



Application

Number of belt with different model				
Load(kg)	Roping Ratio	32kN	43kN	64kN
630	2 : 1	2		
800	2 : 1	3		
1000	2 : 1	4	3	
1250	2 : 1	5	4	
1600	2 : 1	6	6	3

- Calculated by safety factor of 12.
- Nominal strength is counted by minimum breaking force with safety margin.
- Using 3 belts is the most economic efficiency.

Features

- All series products use BASF Elastogran high hardness TPU, it has excellent mechanical and chemical features.
- World class technic to produce high precision galvanized no joint steel rope, with uniform shaping, high fatigue durability and corrosion resistance.
- Focus on surface treatment, equivalent friction coefficient is stable and capable of handling complicated working conditions.
- Online contour scanning system, real-time monitoring of external dimensions to ensure the same quality of every meter of traction belt.
- Traction belt under strict fatigue test during development process. Life time is more than 10 million times bending test.
- Unique **SITONADH™** surface coating for precise galvanized steel core, the bonding force of the steel core and polyurethane exceeds 10 times the national standard, avoiding the risk of delamination and cracking of the steel belt.

32kN Hoisting Belt for Elevator (SYLG-EB-32A)

Item	Unit	Standards
Min Force	kN	32
Width	mm	30
Thickness	mm	3.0
Number of steel core	-	12
Steel core diameter	mm	1.61
Strength of steel core	N	3000
Min bending diameter	mm	80
Weight per meter	g/m	200

32kN Grade Traction Belt

- Suitable for low to medium floor passenger elevators, villa elevators and most elevator applications.
- 30mm width, common size in the market.
- 2:1 and 1:1 roping ratio.
- 12 hyperfine steel cores with only 1.6mm diameter.

34kN Hoisting Belt for Elevator (SYLG-EB-34A)

Item	Unit	Standards
Min Force	kN	34
Width	mm	25
Thickness	mm	3.3
Number of steel core	-	8
Steel core diameter	mm	1.98
Strength of steel core	N	4550
Min bending diameter	mm	100
Weight per meter	g/m	190

34kN Grade Traction Belt

- Suitable for low speed villa elevators.
- Lighter, stronger and more economic.
- 2:1 roping ratio.
- 25mm width applications.
- 8 high precision steel cores with 1.98mm diameter.

43kN Hoisting Belt for Elevator (SYLG-EB-43A)

Item	Unit	Standards
Min Force	kN	43
Width	mm	30
Thickness	mm	3.3
Number of steel core	-	10
Steel core diameter	mm	1.98
Strength of steel core	N	4550
Min bending diameter	mm	100
Weight per meter	g/m	230

43kN Grade Traction Belt

- Suitable for commercial elevators, medium to high floor passenger elevators and heavy load villa elevators.
- 30mm width, common size in the market.
- 10 high precision steel cores with 1.98mm diameter.

64kN Hoisting Belt for Elevator (SYLG-EB-64A)

Item	Unit	Standards
Min Force	kN	64
Width	mm	60
Thickness	mm	3.0
Number of steel core	-	24
Steel core diameter	mm	1.61
Strength of steel core	N	3000
Min bending diameter	mm	80
Weight per meter	g/m	400

64kN Grade Traction Belt

- Suitable for freight elevators, bed elevators and heavy load passenger elevators.
- 60mm width, requires high installation quality.
- 24 hyperfine steel cores with only 1.6mm diameter.

ACCESSORIES - BELT DETECTOR

SJT-BRM Series Belt Detector



Model description of belt detector

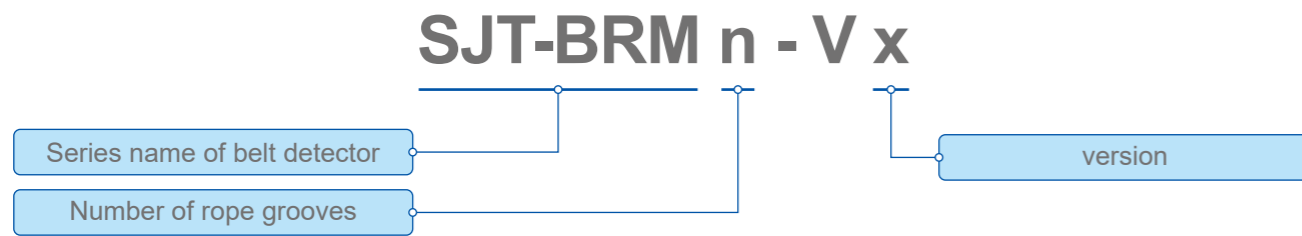

Parameter

Model	Number of rope grooves	Belt model	Number of steel wires per belt	Width	Voltage
SJT-BRM3-V1	2 / 3	SYLG-EB-32A	10 X 12	30	DC24V
		SYLG-EB-43A			

Functional characteristics

- Multiple fault detections: **Steel core open circuit, Short circuit, Steel core exposed.**
 - Steel core open circuit:** One or more steel cores can be detected.
 - Short circuit of steel core:** Two or more steel cores exposed, and the exposed areas can be detected by overlapping and connecting them.
 - Steel core exposed:** One or more steel cores are exposed and can be detected by overlapping with the external metal structure (PE).
- Continuous resistance monitoring: Independent resistance monitoring for each steel strip (resolution $\leq 1\%$)
- Failure alarm output: relay normally open point fault output, independent fault light indication for each belt;
- Multi-steel belt monitoring: 1-3 strips (10-core or 12-core belt);
- Mobile APP debugging: Built-in Bluetooth module, use mobile APP debugging.
- Others: One-click detection / self-learning.

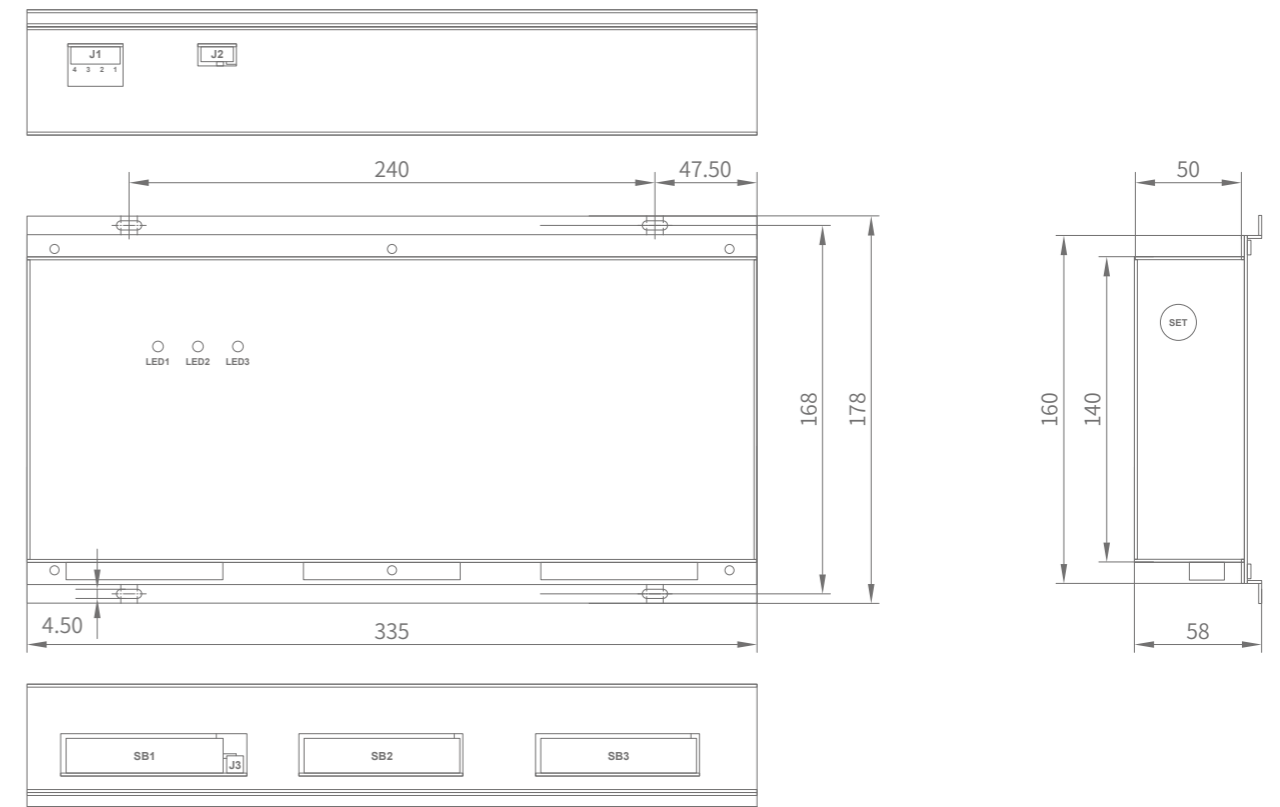

Outline drawing

THE PARAMETER LIST OF GROOVE

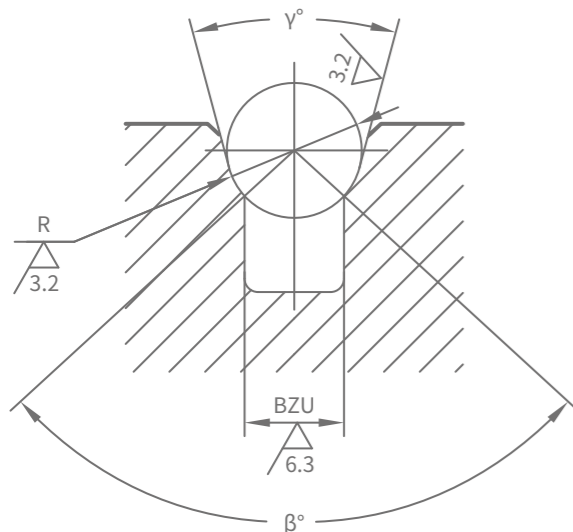

Single groove

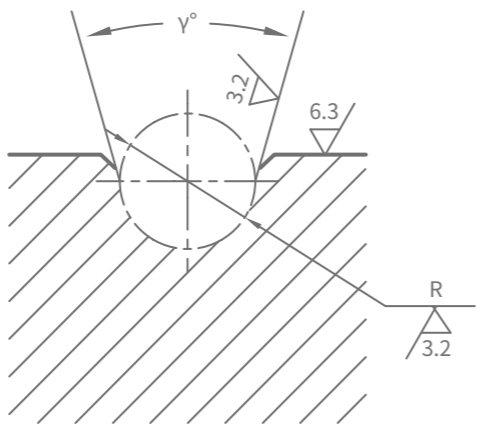

Double groove

Groove	R	β	γ	BZU
Single groove	Ø6	90°	35°	4.24
	Ø8	90°	30°/35°	5.66
	Ø10	97°	25°	7.49
	Ø12	95°	35°	8.85
Double groove	Ø10		35°	
	Ø12		35°	
	Ø16		35°	