

**THE DISC BRAKING SYSTEM
INSTRUCTION MANUAL**

VERSION: A0

DATE: JUL., 2016

CONTENTS

1. INTRODUCTION.....	3
2. WARNINGS.....	3
3. INSTALLATION	4
3-1. Installing the clamper.....	4
3-2. Wiring.....	6
4. GENERAL DESCRIPTION.....	6
4-1. Operation.....	6
4-2. Components.....	8
5. BEFORE OPERATION	10
5-1. Adjusting pad pressing force.....	10
5-2. Adjusting coil stroke.....	10
5-3. Adjusting air gap	11
5-4. Breaking in new pads	13
6. MAINTENANCE	13
6-1. Checking air gap.....	14
6-2. Checking coil stroke	14
6-3. Checking pad wear allowance	14
6-4. Checking disc sliding surface	14
6-5. Checking dust cover	15
6-6. Checking operating noise produced when iron core is attracted.....	15
6-7. Greasing torque receiving pin.....	15
6-8. Checking for worn bushing at the torque receiving area	15
6-9. Checking bolts for looseness	16
7. MANUAL RELEASING	16
8. EXPENDABLE PARTS	17
9. TROUBLESHOOTING GUIDE.....	17
10. SPECIFICATIONS.....	18
Appendix 1 MANUAL RELEASING PROCEDURE	20

The disc braking system instruction manual

Brake model : EC-4026EF-100

Read and understand this instruction manual before operating the electromagnetic clumper.
Improper operation or servicing might cause a serious accident.

NOTICE!!! Before adjust the braking system should confirm the car's position to prevent strong tip and crouch driver of

WARNING! When the machine has load, do not adjust the two brakes at the same time.

ATTENTION! When adjusting the braking system, be sure that the one brake has enough braking force, and then

1. INTRODUCTION

This EF-type electromagnetic clamber is used for holding an elevator traction machine stationary after it has stopped, and also for stopping it in emergencies.

Read this manual thoroughly and become completely familiar with the clamber before proceeding with operating and servicing. Keep the manual in a specified place for ready reference for anyone who may operate or service the clamber, to read it as necessary.

2. WARNINGS

2-1. Allow only qualified personnel to install, operate, and service the electromagnetic clamber.

Improper handling might cause injury or a serious accident.

2-2. Be sure to adjust the coil stroke to the specified setting before installing the clamber or performing periodic inspection.

Improper coil stroke adjustment will cause poor pad pressing force (braking torque), thus causing improper holding of the traction machine or improper braking in emergency. In the worst case, the cage (transportation unit) might fall, resulting in a serious accident.

For the coil stroke adjustment procedure, refer to section 5-2, "Adjusting coil stroke" on page 10 and adjust it correctly.

2-3. Do not inspect both the right and left clampers at the same time. Keep either of the clampers operating at all times.

Be sure to inspect one clamber at a time. Remember that air gap adjustment requires a clamber to be released temporarily, which will make the pad pressing force (braking torque) become zero. If you adjust the air gaps of both clampers simultaneously, the cage (transportation unit) might drop or the brake disc may rotate unexpectedly, causing a serious accident.

2-4. Clean the sliding surface of the brake disc, as necessary, before installing the clamper or performing periodic inspection.

Remove oil, grease or dust from the sliding surface of the brake disc in order to keep the specified pad pressing force (braking torque). Furthermore, consider the installation position of the clamper or use a cover for the clamper to prevent oil or grease from adhering to the disc surface during elevator operation.

2-5. Do not modify the product.

Modification of the product might cause an injury or a serious accident.

2-6. Make sure that the emergency stop function operates properly.

Improper operation may cause an injury or a serious accident.

2-7. Do not use the clamper outside of the specification range.

The clamper may break or there is a danger of causing an injury or a serious accident.

3. INSTALLATION

3-1. Installing the clamper

This EF-type electromagnetic clamper has the forced releasing bolt and adjustment bolt locked in the positions which provide the gap between the pads wider and the disc thickness for ensuring easy installation.

Be sure to remove the forced releasing bolt after installing the brake unit.

1) Align the clamper's pads with the disc properly, and then install the torque receiving pin.

2) Make sure the distance between the clamper's torque receiving area and clamper mount is set to 1 to 4 mm (standard: 3 mm).

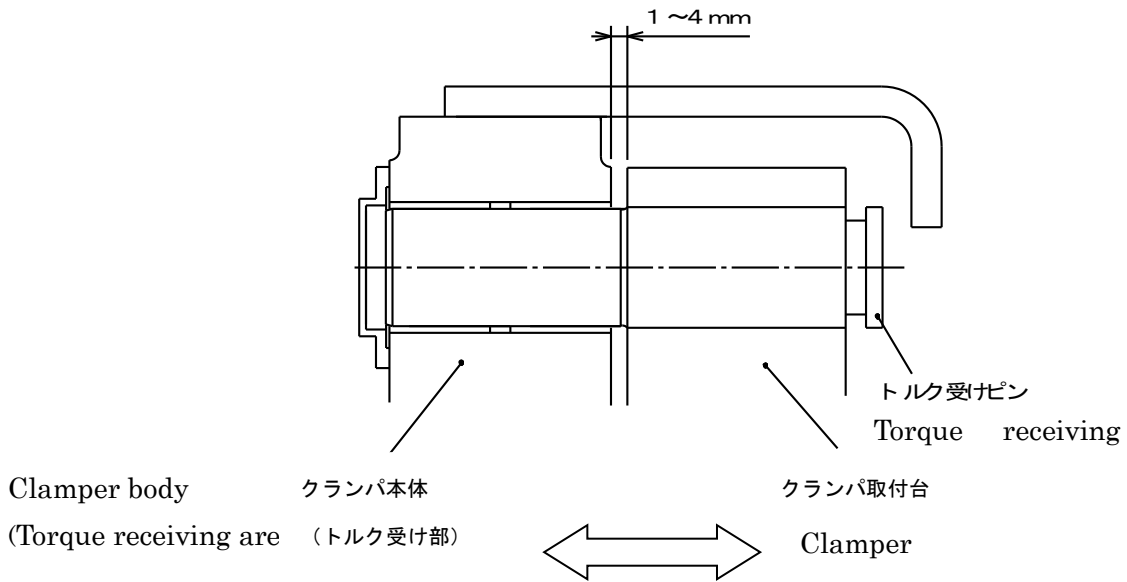

Make sure the clamber body slides smoothly.

3) Make sure that the clamber body slides smoothly on the torque receiving pin (150 N or less).

4) Set the clearance between the pads and disc to about 1 mm using the adjustment bolt (13).

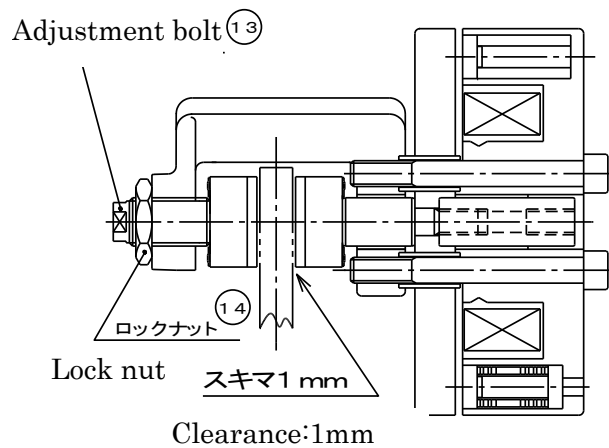

5) Remove the forced releasing bolt (58) and plate (57).

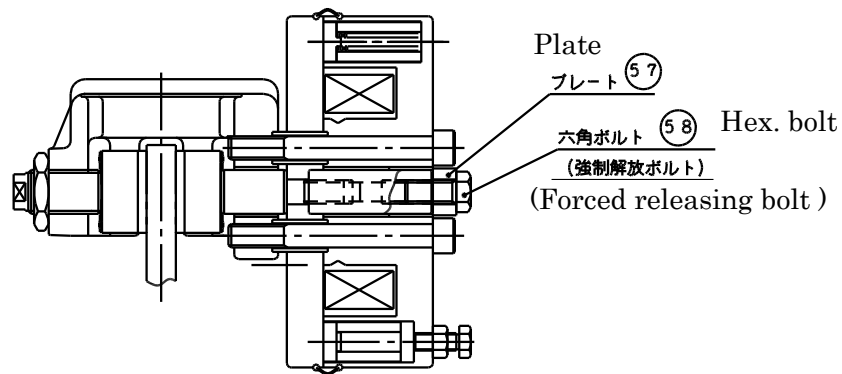

3-2. Wiring

Before performing any wiring work, make sure that the power supply is shut off; otherwise it will cause an electrical shock accident.

1) When securing the electric wires for the coil and limit switch, give them a slack large enough to absorb the slide (1 mm or less) of the clamper.

Also, give the wires a slack large enough to allow the clamper to turn around the torque receiving pin (lower part) when replacing pads.

Note: The clamper operation isn't affected even if the coil is connected to either (+) or (-).

4. GENERAL DESCRIPTION

This clamper is designed to produce pad pressing force (braking torque) with the spring built inside the coil assembly and release the clamping (braking) force by energizing the coil.

4-1. Operation

4-1-1. Producing clamping (braking) force

1) When electricity to the coil of the clamper is shut off, the movable

iron core leaves the coil and the right-side pad advances (to the left) by spring force until it comes in contact with the disc.

2) Furthermore, the right-side pad continues to advance, moving the caliper and coil assembly to the right along the torque receiving pin until the left-side air gap becomes zero.

3) When the right and left air gaps become zero, the pads are pressed against the disc by spring force, producing the clamping (braking) force.

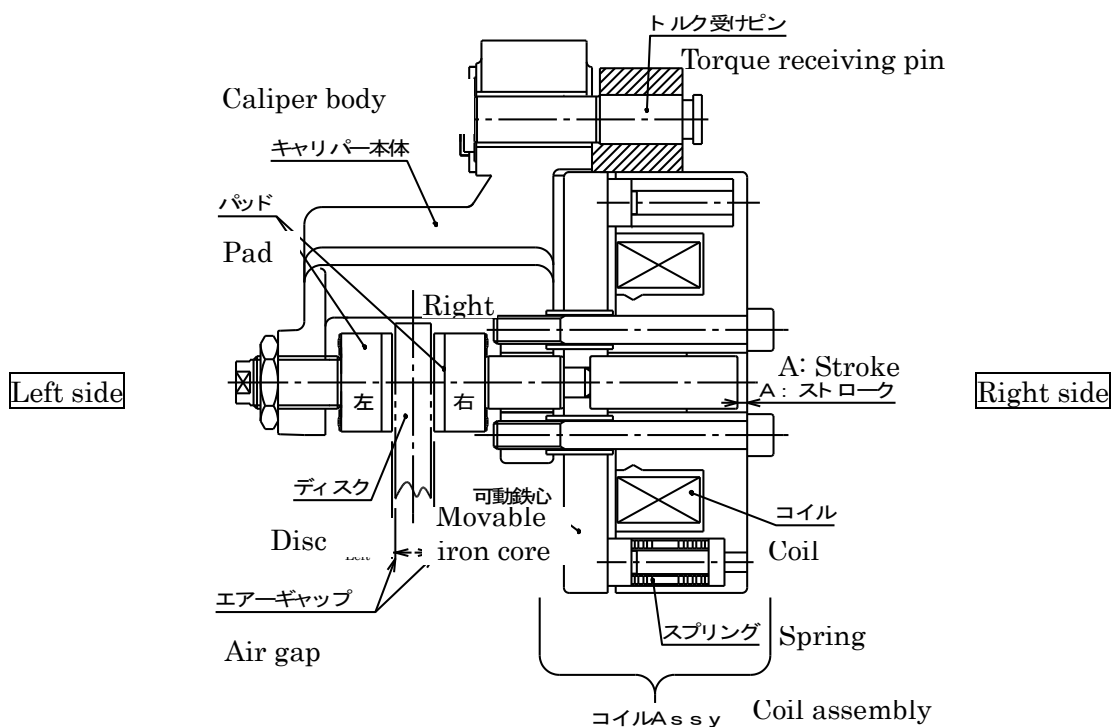

4-1-2. Releasing clamping (braking) force

1) When the coil of the clamber is energized, the movable iron core overcomes the preset load of the spring force and is attracted to the coil. The pad pressing force is eliminated, thus releasing the clamping (braking) force.

2) In the above explanation, only the right-side air gap is created by the movable iron core stroke (dimension A) with the left-side pad in contact with the disc. But, actually, both the right and left air gaps are produced by adjusting the air gap according to section 5.3, “Adjusting air gap” on page 11.

4-2. Components

(The figures below show the right side of the clamper.)

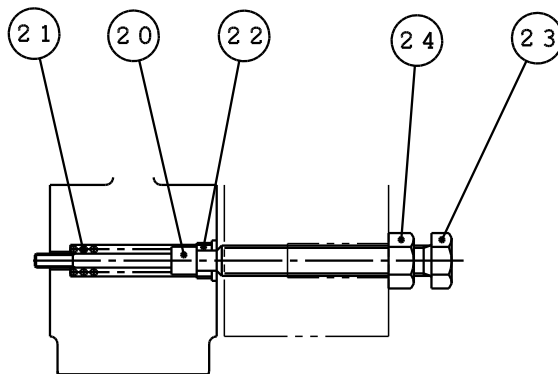
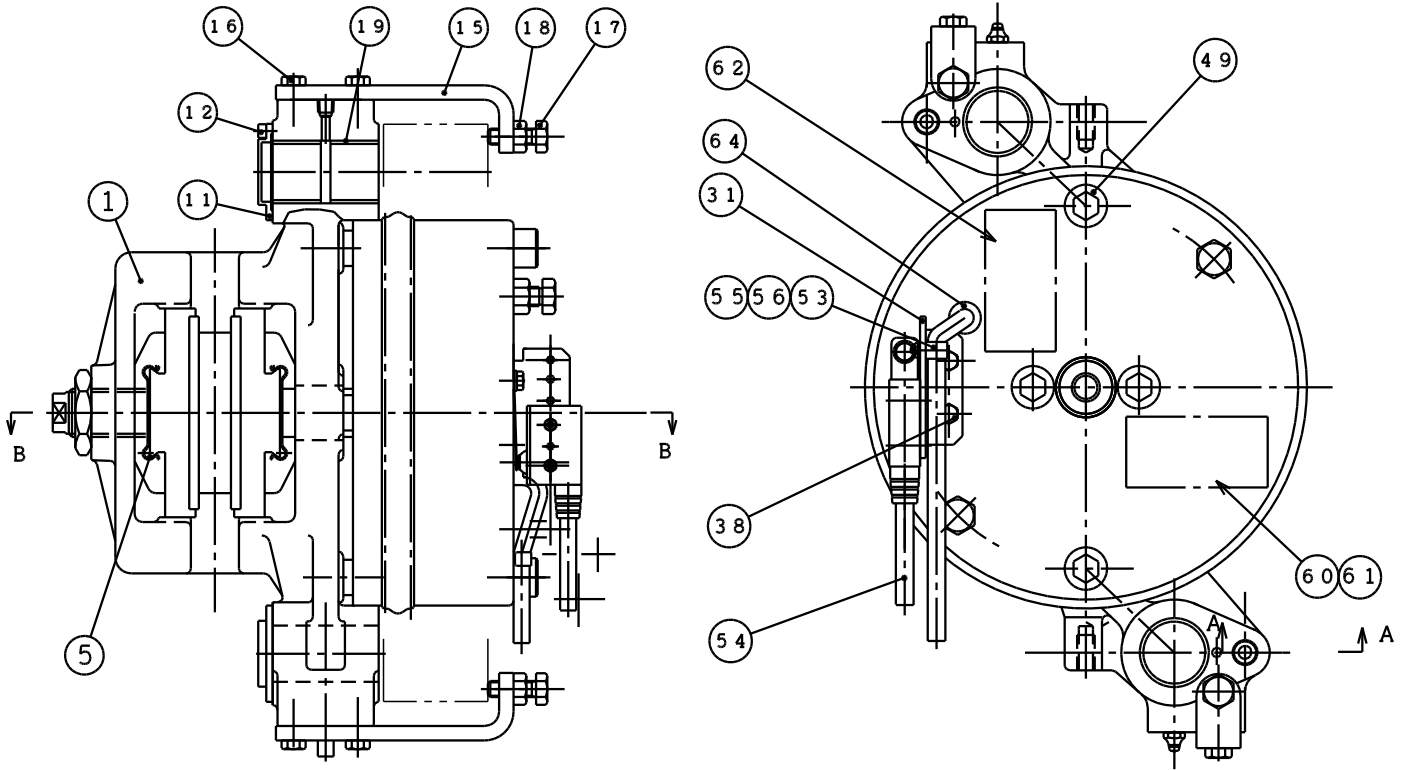

Section A-A

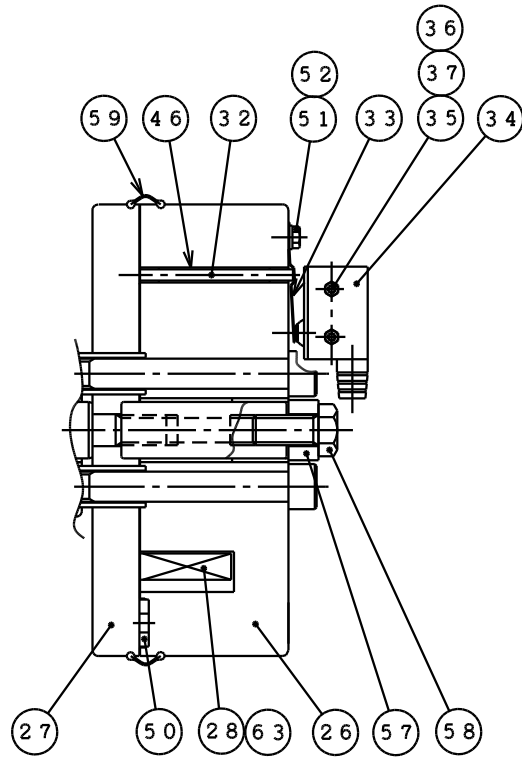

Limit switch

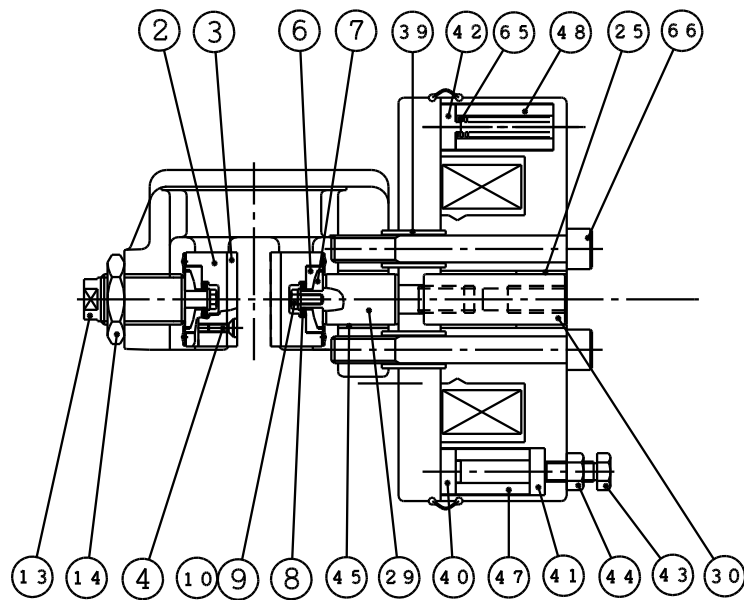

Section B-B

Disc sectional view

5. BEFORE OPERATION

5-1. Adjusting pad pressing force

The pad pressing force is determined by dimension (X) (the compression of the spring inside the coil) and the air gap (the clearance between the pads and disc).

Adjust dimension (X) according to the procedure described below.

1) Determine dimension (X) corresponding to the pad pressing force you want to have. (Refer to the pressing force characteristic curve shown on page 19.)

2) Loosen the hex. nut (44) (for locking), and then turn the torque adjusting bolt (43) so that dimension (X) has the value determined at step 1).

Note: The pad pressing force (braking torque) is increased by turning the torque adjusting bolt clockwise; and it is decreased by turning the bolt counterclockwise.

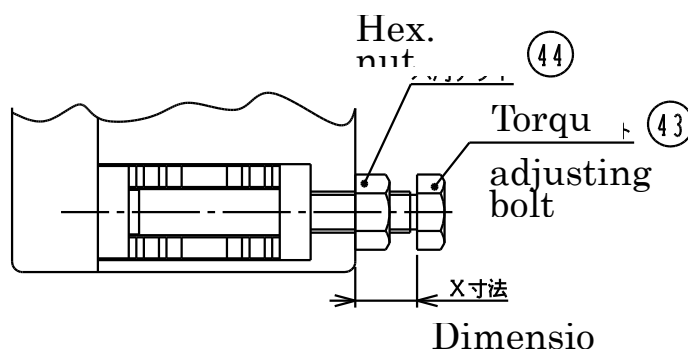

5-2. Adjusting coil stroke

1) With the side face of the coil's fixed iron core grounded, apply the dial gauge to the tip of the rod (30).

2) Energize the coil (attraction).

3) With the coil energized, set the dial gauge to 0.

4) Read the dial gauge with the coil de-energized (drop-away)

(The coil stroke is the difference between when the iron core is attracted to the coil and when the iron core is not attracted.)

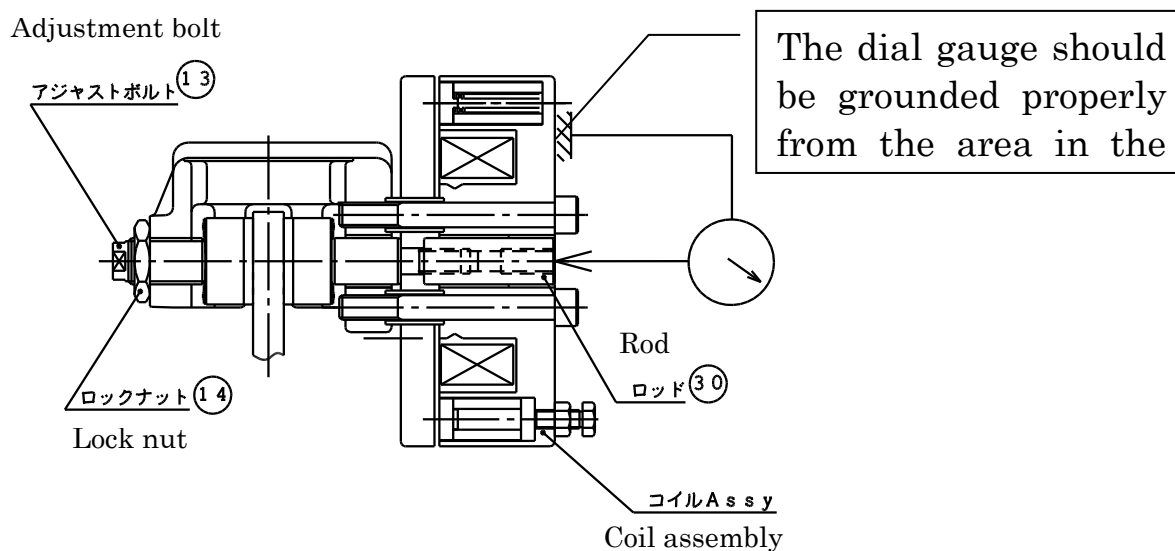

5) Energize and de-energize the coil repeatedly to adjust the coil stroke to 0.5 mm with the adjustment bolt (13). After adjustment, secure the adjustment bolt (13) with the lock nut (14).

*The pads advance toward the disc side when the adjustment bolt is turned clockwise.

*Make sure that the coil is energized and the movable iron core is attracted to the coil before trying to turn the adjustment bolt.

(Do not try to turn the adjustment bolt while in a de-energized (drop-away) state. Otherwise the internal bolt may become loose.)

5-3. Adjusting air gap

(the clearance between the pads and disc)

1) De-energize the coil to turn on the brake and loosen the lock nut (24) for the adjusting bolt (23) (M12). Turn the adjusting bolt (23)

counterclockwise until a clearance is produced between the adjusting bolt (23) and return pin (20); tighten it clockwise until the adjusting bolt (23) comes in contact with the return pin (20); and further tighten about 45 degrees. (2 locations at top and bottom) After adjustment, tighten the lock nut (24) to secure the adjusting bolt (23).

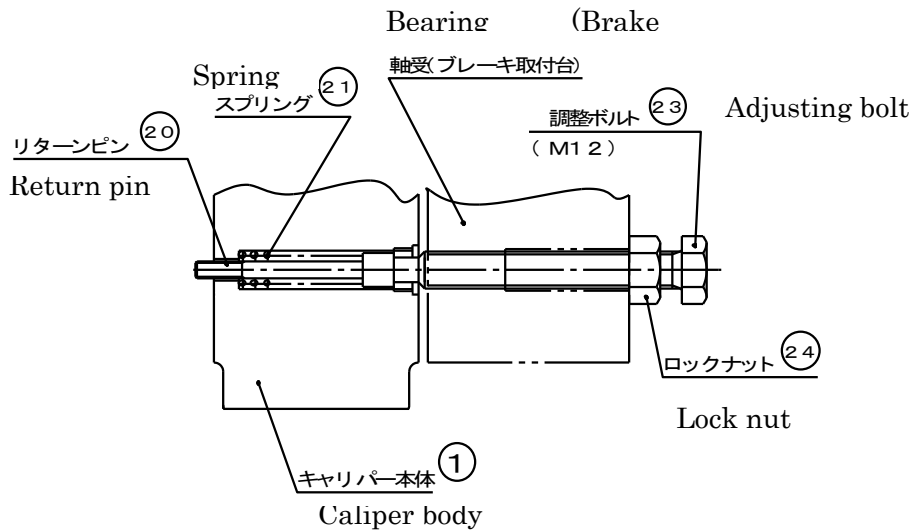

2) Energize the coil to release the brake. After loosening the lock nut (18) for the adjusting bolt (17) (M10), tighten the adjusting bolt (17) (M10) clockwise until the right and left air gaps become equal (check visually). (2 locations at top and bottom)

After adjustment, tighten the lock nut (18) to secure the adjusting bolt (17) (M10).

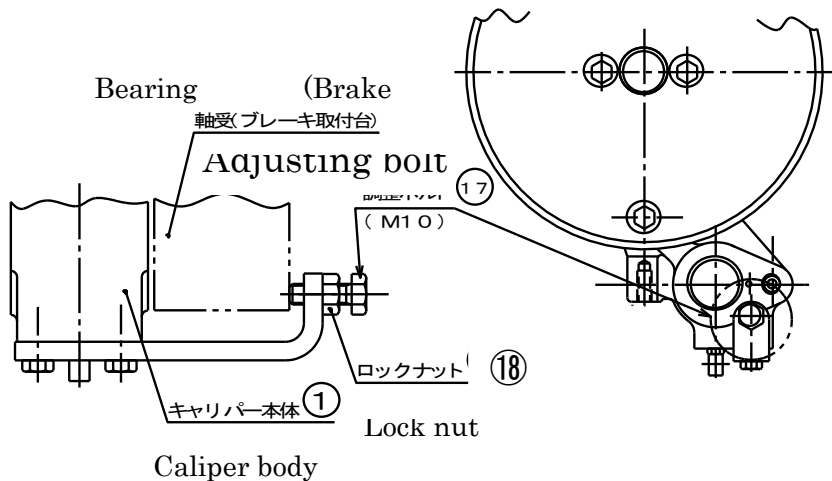

5-4. Breaking in new pads

Whenever using newly installed pads, “break in” new pads to the disc sufficiently to obtain the necessary braking torque. Insufficient break-in might not produce the specified braking torque.

◎ How to break in new pads to the disc (Example)

1) With the disc being rotated by the motor, turn on and off the brake (= inch the brake) repeatedly, thus allowing new pads to break in.

2) Wait until the disc cools down to the ambient temperature (less than 40°C). Then measure the braking torque to check that the braking torque required for the preset size X (pad pressing force) is produced.

The conditions used for the break-in procedure (disc rpm, inching interval, and the number of times of break-in, etc.) should be determined by considering the characteristics of the motor to be used, working properties, necessary braking torque, and the following items.

<Precaution>

(1) Before starting the break-in procedure, adjust dimension X of the clamper properly so that the clamper’s braking torque is less than the rated torque of the motor to be used for breaking in new pads.(Otherwise, the disc won’t rotate and the break-in procedure cannot be performed.)

(2) When applying and releasing (inching) the brake with the disc being rotated, take an inching interval that keeps the disc surface temperature below 100°C.

(3) Once the break-in procedure is completed, recheck dimension X, coil stroke, and air gap.

6. MAINTENANCE

Periodic inspection is necessary to maintain the performance of the EF-type electromagnetic clamper. Be sure to check the clamper at periodic intervals. It is recommended to carry out periodic inspection every 6

months or less. Periodic intervals vary with the operating condition. If emergency braking has been applied, perform steps 6-1 through 6-4 below.

6-1. Checking air gap (the clearance between disc and pads)

Make sure that neither pad is touching the disc. If either pad is in contact with the disc, adjust the air gap according to section 5-3, “Adjusting air gap” on page 11.

6-2. Checking coil stroke

If the coil stroke exceeds 0.7 mm, readjust it.

For the procedure for adjusting the coil stroke, refer to section 5-2, “Adjusting coil stroke” on page 10.

6-3. Checking pad wear allowance

Replace the pad assembly when either of the pads is worn to the pad wear allowance mark.

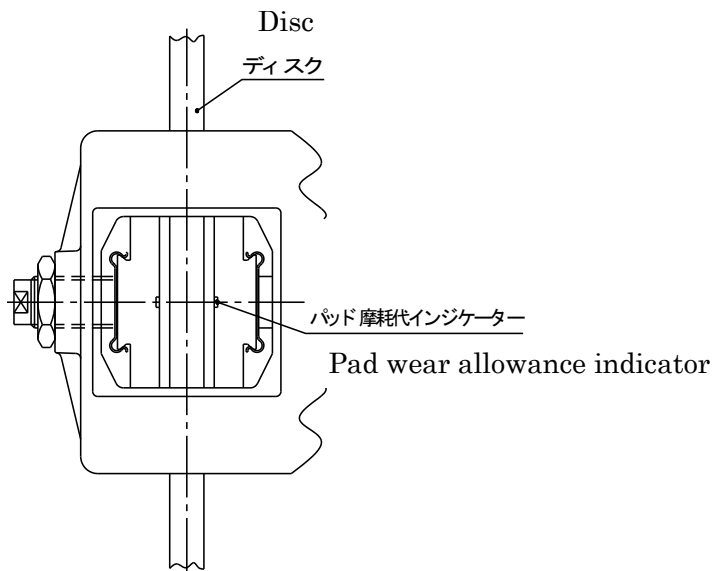

6-4. Checking disc sliding surface

Check the disc sliding surface for oil, rust or roughness. If the disc sliding surface appears contaminated with oil, clean it with acetone or thinner. If any rust or roughness is found, repair the surface with sand paper.

6-5. Checking dust cover

The dust cover is made of rubber so that it may be cracked due to deterioration. If the dust cover is cracked or broken, replace it with a new one.

6-6. Checking operating noise produced when iron core is attracted

A cushion rubber is built inside the coil for absorbing operating noise when the iron core is attracted to the coil. If the operating noise is 75 dB (A) or more, it indicates the cushion is deteriorated. Replace it with a new one.

6-7. Greasing torque receiving pin

Supply Albania grease through the grease nipple until grease comes out from the clamper body. Wipe off any excess grease.

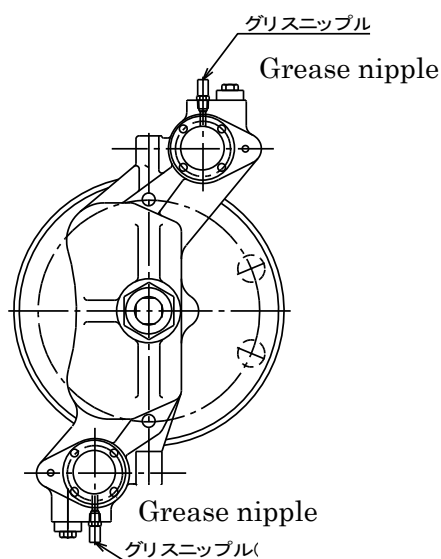

6-8. Checking for worn bushing at the torque receiving area

When the clamper is used for stopping and holding, the clamper unit moves vertically due to the clearance between the pin and bushing. If the movement of the clamper exceeds 0.15 mm, replace the bushing with a new one.

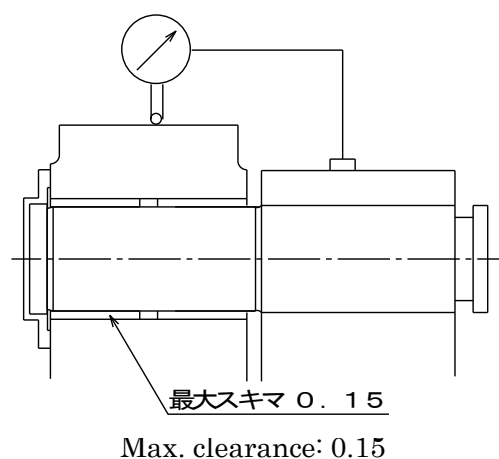

6-9. Checking bolts for looseness

Check each bolt for looseness.

In particular, carefully check the hex. socket head bolts (49) and (66) and the lock nut (14) for looseness.

7. MANUAL RELEASING

If it is necessary to release the clamper manually due to power failure, installation or periodic inspection, use the manual release lever to release the clamper.

(See the separate “Appendix 1 Manual Releasing Procedure”.)

WARNING: Do not release the brake with the attached forced releasing bolt.

It is difficult for you to use the forced releasing bolt quickly enough to operate the brake.

8. EXPENDABLE PARTS

	Component Name	Component No.	Q'ty
1	Pad assembly	(2) (3) (4)	4
2	Dust cover	(59)	2
3	Cushion rubber	(50)	16
4	Limit switch	(34)	2
5	Torque receiving metal	(19)	8

Expendable parts list

Note: Each number in the Q'ty column shows the quantity required for one elevator.

9. TROUBLESHOOTING GUIDE

If any trouble occurs during operation, see the table below.

	Problem	Remedy
1	Clamper won't be released. (It won't be attracted or held.)	<ul style="list-style-type: none"> ⊙ Check the control circuit. ⊙ Check the wiring. ⊙ Check the pick-up voltage and holding voltage. ⊙ Check the coil stroke. ⊙ Check if the clearance between the iron cores is 0 (in close contact with each other) when the iron core is attracted to the coil. (Make sure that no dust is caught between the iron cores.)

2	No braking torque is produced.	<ul style="list-style-type: none"> ⊙ Check the pads and disc for the adherence of oil. ⊙ Check that the forced releasing bolt is not installed. ⊙ Check the torque adjustment.
3	Limit switch won't operate.	<ul style="list-style-type: none"> ⊙ Check the limit switch for damage. ⊙ Check the contacts of the limit switch. ⊙ Check the wiring. ⊙ Check the operation range.

10. SPECIFICATIONS

- 1) Braking force Adjustment range : 4393 to 8206 N-m
(when using 2 clampers)
- 2) Disc outer diameter : 900 mm
- 3) Coil voltage Rating : 90 VDC per clamper
Adjustment range : 81 VDC to 99 VDC
- 4) Coil stroke Rating : 0.5 mm
Operating range : 0.5 – 0.7 mm
- 5) Min. pickup voltage : 64 VDC or less per clamper
- 6) Min. holding voltage : 28 VDC or less per clamper
- 7) Recommended holding voltage : 40 VDC ±10% per clamper
- 8) Brake response time Braking : 0.3 sec or less
(at max. pad pressing force) Releasing : 0.55 sec or less
- 9) Coil resistance (at 20 °C) : $19.2 \pm 0.1 \Omega$
- 10) Dielectric strength : 2000 VAC for 1 minute
- 11) Insulation resistance : 100 MΩ or more
- 12) Limit switch contact : Contact B (NC)

- 13) Pad wear allowance : 1 mm
- 14) Ambient temperature : -10 °C to +50 °C
- 15) Ambient humidity : 95% RH or less
- 16) Mechanical durability :20 million operations or more
(except for expendable parts)
- 17) Coil temperature rise (resistance method): 45 °C or less
- Conditions: 3 times/min, 50% ED (attracting for 1.0 sec; holding for 9.0 sec, outage 10s, rated voltage)
- 18) Operating noise : 70dB (A) or less
- 19) Weight : 55 kg per clamper
- 20) Pad pressing force characteristic curve (when the stroke is 0.5 mm; per clamper)

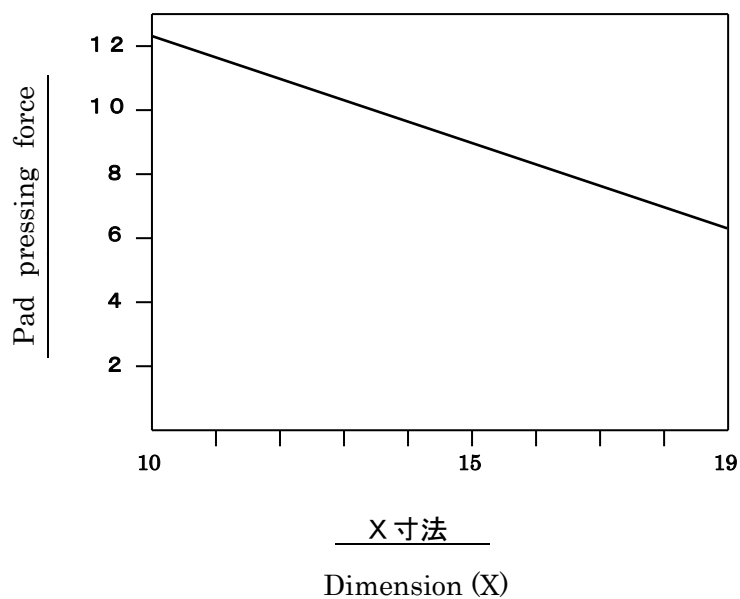

Note: The operating noise of 70 dB or less is the value obtained when the noise was measured at a distance of 1 m from a single clamper using the service brake.

Appendix 1 MANUAL RELEASING PROCEDURE

**Read and understand this manual before operating the disk brake unit.
Improper operation or servicing might cause a serious accident.**

1. Introduction

This manual release lever is used for lowering the transportation unit safely in emergency such as a power failure.

Handle this lever properly to manually release the brake in a safe manner.

Keep the instruction manual in a specified place for ready reference for anyone who may operate or service the brake, to read it as necessary.

2.Warning

The brake is completely released when the manual release le

Do not use this lever except in emergency such as a power failure.

3.Installation

Install the manual release lever and the hex. headed bolt (M16 x 110L) onto the threaded part at the center of each of the right and left brake coils. Fasten them with a spanner securely.(Install the lever in the neutral position.)

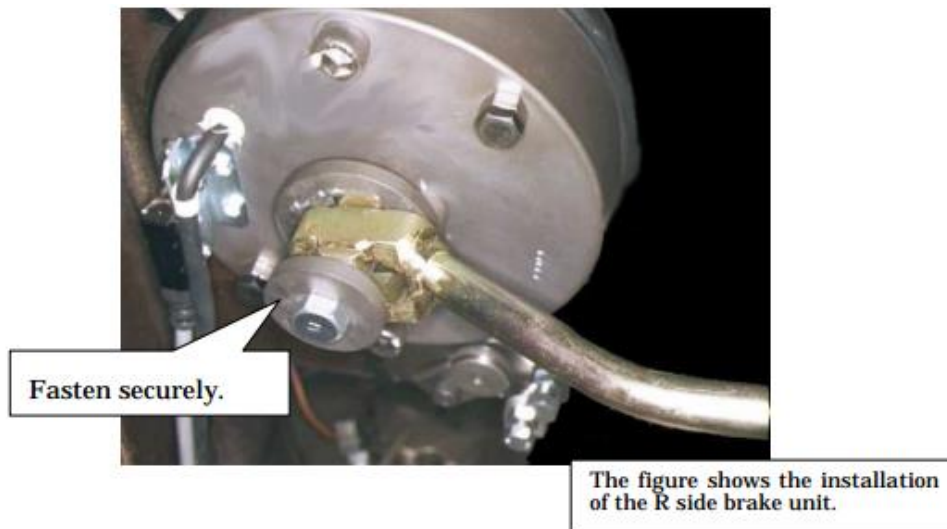

4. Operation

WARNING

The brake is completely released when the manual release lever is used.
Do not use this lever except in emergency such as a power failure.

4-1 When you pull the lever toward you or push it to the far end, the air gap is widened to release the brake. When you return the lever to the neutral position, the brake is applied.

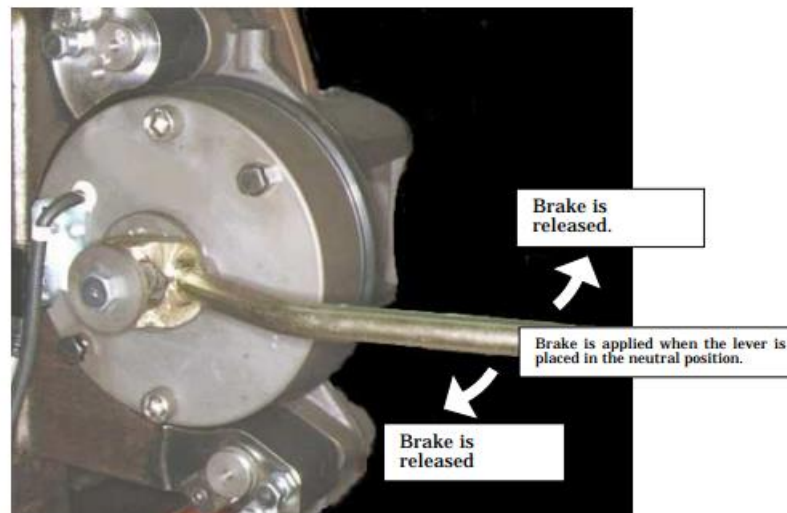

4-2 The transportation unit can be lowered by releasing the right and left brakes simultaneously using the release lever.

4-3 After lowering the transportation unit remove the manual release lever.