

General Planning

Key Bowling Lane Dimensions

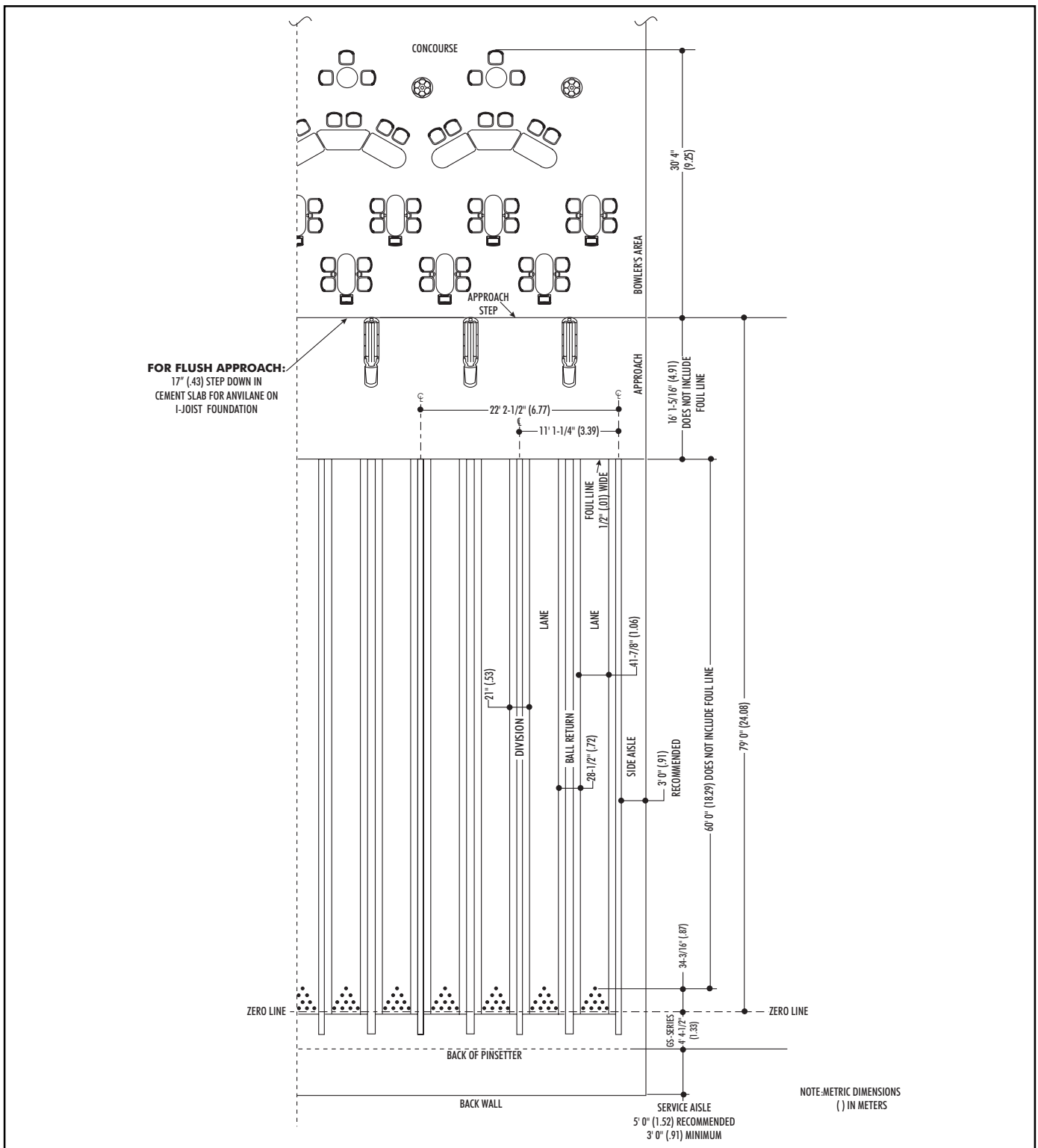

Lane Dimensions

Building Width

The width of the building is determined by adding the following:

- Width/thickness of outside walls
- Side aisles
- Columns
- Lane area

Bowling Lane Widths

The following dimensions are net measurements of the uninterrupted lane widths only, and therefore, additions should be made for columns, walls, and passages between lanes or beside them.

No. of Uninterrupted Lanes	Minimum Width 10-1/2" Returns
2	11' 6" (3.51m)
4	22' 7-1/4" (6.89 m)
6	33' 8-1/2" (10.27 m)
8	44' 9-3/4" (13.66 m)
10	55' 11" (17.04m)
12	67' 0-1/4" (20.43m)
14	78' 1-1/2" (23.81m)
16	89' 2-3/4" (27.20m)
18	100' 4" (30.58m)
20	111' 5-1/4" (33.97m)
22	122' 6-1/2" (37.35m)
24	133' 7-3/4" (40.74m)
26	144' 9" (44.12m)
28	155' 10-1/4" (47.5m)
30	166' 11-1/2" (50.89m)
32	178' 0-3/4" (54.27m)
34	189' 2" (57.66m)
36	200' 3-1/4" (61.04m)
38	211' 4-1/2" (64.43m)
40	222' 5-3/4" (67.81m)
42	233' 7" (71.20m)
44	244' 8-1/4" (74.58m)
46	255' 9-1/2" (77.97m)
48	266' 10-3/4" (81.35m)

NOTE: For each additional pair of lanes above 48 lanes, add 11' 1-1/4" (3.38 m)

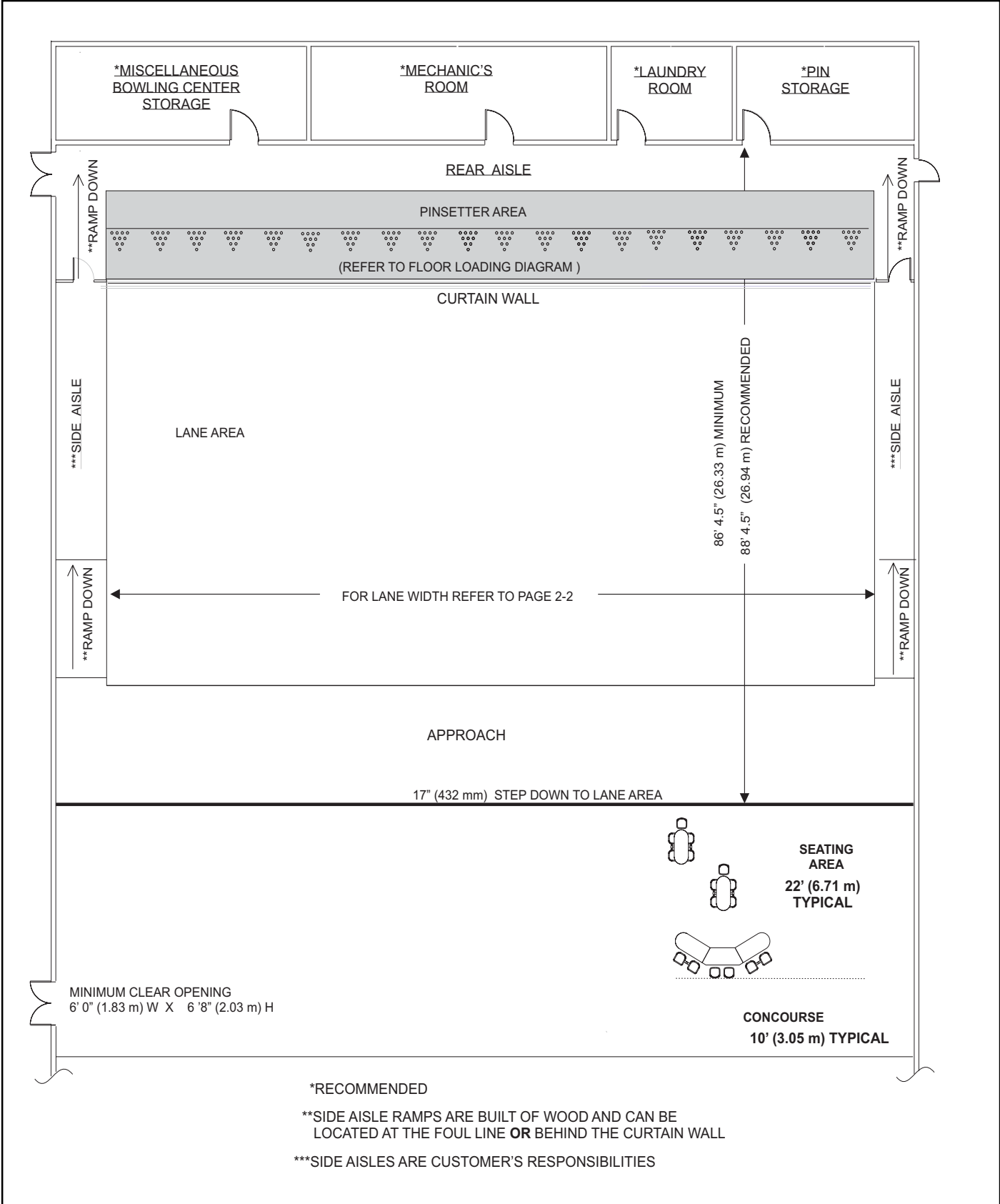

*RECOMMENDED

**SIDE AISLE RAMP ARE BUILT OF WOOD AND CAN BE LOCATED AT THE FOUL LINE OR BEHIND THE CURTAIN WALL

***SIDE AISLES ARE CUSTOMER'S RESPONSIBILITIES

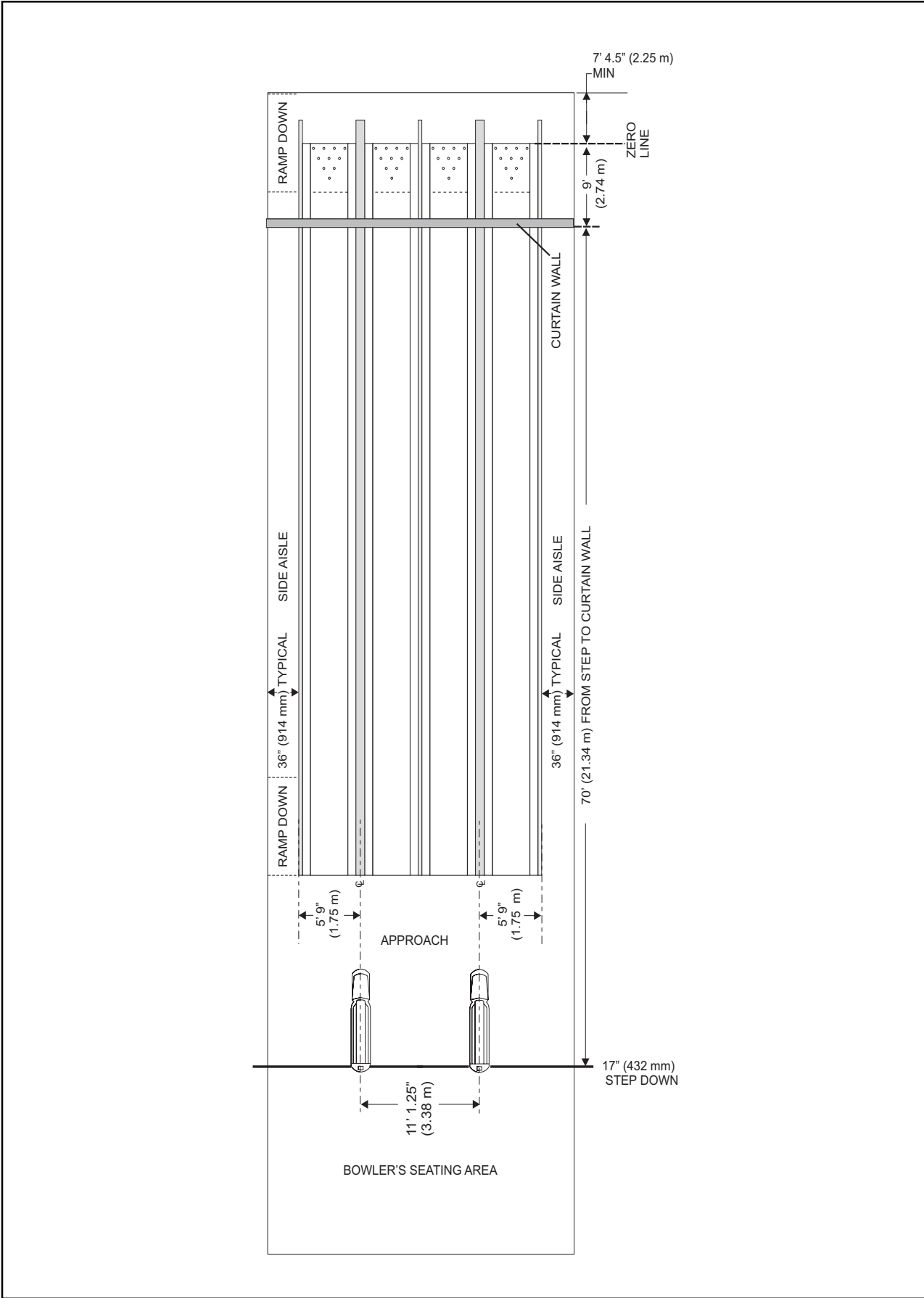

Concrete Floor Layout Lane Dimensions (top view)

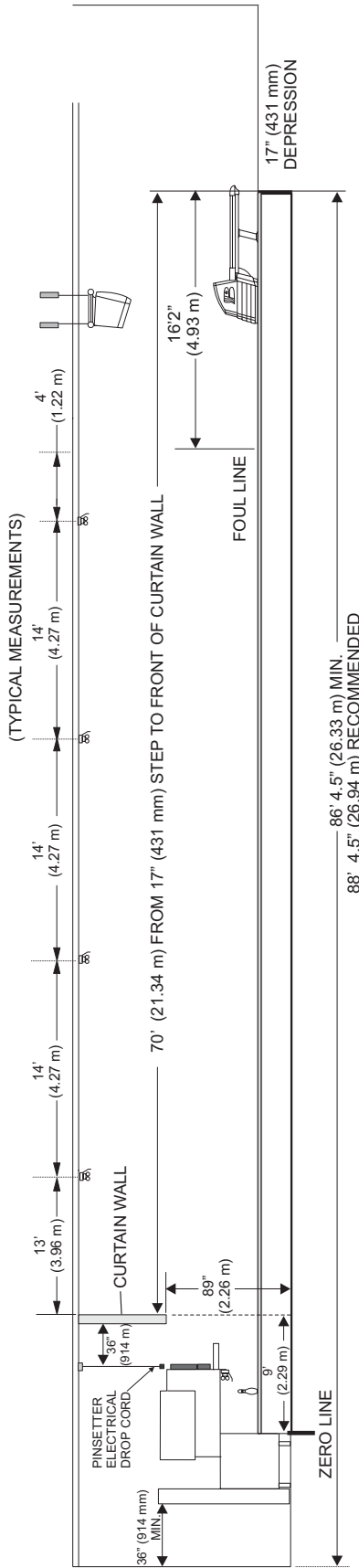

SECTION AT BOWLING LANE

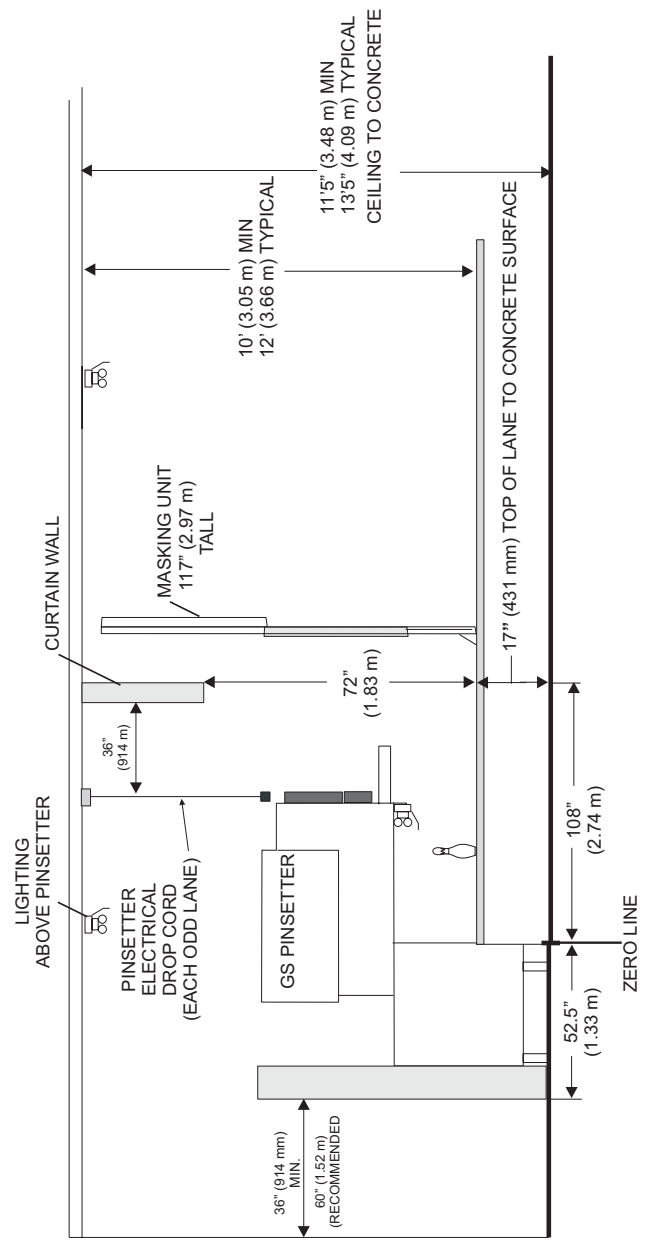

Lane Dimensions (side view)

Column Spacing

Ideally, a clear span is preferred. However, where supports for the structure above the lane are necessary or existing, it is desirable to use a minimum lateral spacing between columns of 22' 7-1/4" (6.89 m) per four lane bay plus 1" (2.54 cm) for clearance to reduce transmission of noise.

Longitudinally, the fewer columns the better. The 16' 1-5/16" (4.91 m) approach area and at least 2' (.61 m) beyond the foul line should be kept free of columns if possible.

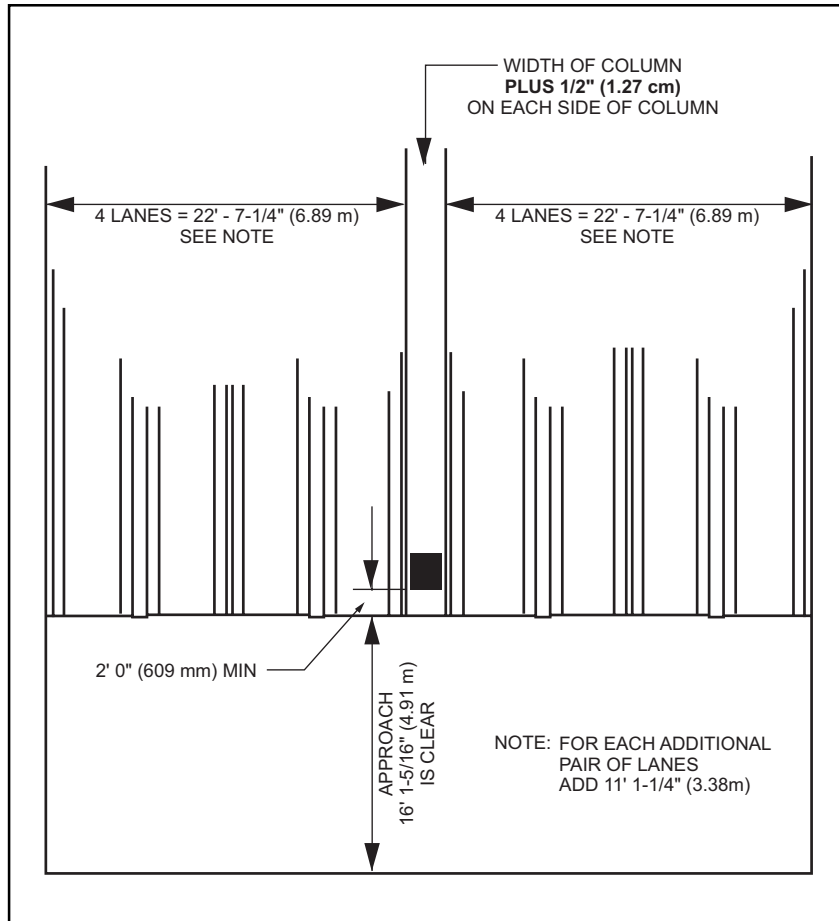

Column Spacing

Side Aisles

The width of side aisles is determined by the economical width of the building. It serves as a convenient indoor route for personnel to the pinsetters and storage areas. A side aisle width of 3' (.91 m) is suggested with a ramp down at the foul line or behind curtain wall. If no side aisle is provided, at least 1' (30.5 cm) should be allowed from the outside edge of the gutter to the wall to give the bowlers freedom on the approach.

It is the **customer's responsibility to construct ramps and side aisles**. If approach level side aisles are desired, additional I-joists are available from Brunswick.

Other Building Considerations

Storage, Shops, and Service Aisles

Your building plans should provide for a special area that also functions as a work area, washroom, shower, laundry facility, bowling pin storage, and miscellaneous storage. A mechanic's room is typically located in the center of lanes for quick response and efficient maintenance. Since the pinsetter area is a noisy area, this shop should be so constructed as to be as quiet as possible for maximum work efficiency of the mechanic. The depth of this area generally varies from 8' (2.44 m) to 14' (4.27 m), while the width depends on the space for the above mentioned operations. Provide fireproof cabinets for combustible items. Fireproofing and good ventilation should be provided in accordance with local codes. Explosion-proof electrical fixtures should also be provided.

Equipment Length

The total length of the bowling area is determined by using a recommended 5' (1.52 m) clear service passage behind the lanes and the overall length of the bowling lanes, which is 83' 4-1/2" (25.41 m) and includes the pinsetter, lane and approach. To these dimensions add an area for the bowlers' seating, based on seating configuration. Refer to *Architectural Layout* section 9.

Concourse

The concourse, which is in back of the spectator seating, may vary in width. The clear width should be ample to accommodate at least a peak load of 10-15 people per lane. The maximum milling area is generally located around the control counter, snack bar, restaurant, and entrance lobby. Vending machines, ball cleaners, etc., are usually located on the concourse, preferably recessed. Concourse tables and chairs can help turn this area into an income-producing area. Adequate wall area should be provided for bulletin boards, scoresheets, and other announcement boards. Your Brunswick representative will inform you of these requirements and give suggestions for nonstandard layouts. House ball storage racks will also be necessary. Consider these factors when planning your concourse.

Variables - Public Area Accommodations

The design of companion accommodations include items such as the following:

- Lounge/Bar
- Quick service bar or window
- Snack bar and/or restaurant
- Pre-cooler
- Game room
- Billiards room or area
- Rest rooms
- Ladies' lounge
- Locker area
- Maintenance equipment storage area
- Public telephone
- Telephone solicitation area
- Meeting rooms
- Banquet facilities
- Children's activity center
- Office(s) for owner/manager and other key staff
- Reception Center
- Heating, humidity control and air conditioning equipment
- Smoke control/air purifiers
- Pro shop
- Vending machines
- Electronics systems room
- Handicap accessibility
- Party Rooms
- Smoker's Lounge

Reception Center

The reception center, bar and snack bar should be proportioned to capacity lane conditions and be easily accessible from any part of the lanes. Should billiards be part of your building plans, the reception center should be positioned within view of both bowling and billiards (or game room) to avoid the need for a separate reception center for both.

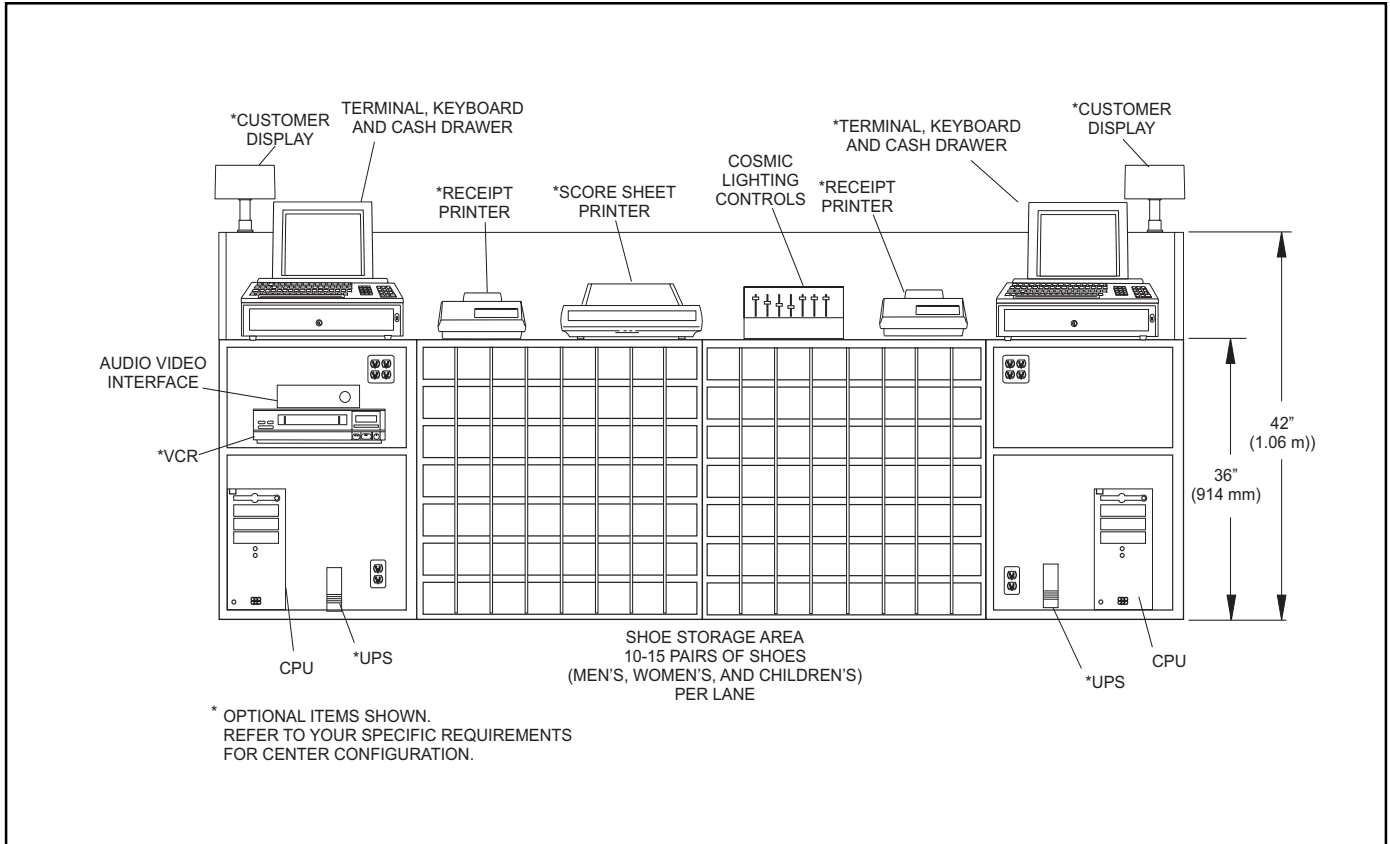

Typical Reception Center Equipped with Brunswick Center Management Equipment

Billiard Rooms

Some communities have ordinances governing public billiard rooms. Therefore, it is advisable to investigate local laws in your pre-planning stages.

Normally, pocket tables of professional size or the small coin operated tables are used, isolated from the bowling lane area, but within close proximity to the reception center for the convenience of the control counter personnel.

Billiard rooms are family-oriented in decor. Carpeting is popular today, particularly the static-control type now available. If tile is preferred, Brunswick suggests vinyl for durability and ease of maintenance. Lighting of **50 to 75 footcandles** of even intensity on the playing surface 30" (.76 m) above the playing surface is desirable. The best type of fixtures are flush ceiling-mounted, centered over each table with a baffled diffuser to concentrate light over the playing surface.

Your wall treatment should provide easy maintenance, while adding to the at-home family type environment. Many types of wood paneling are available and are easy to maintain, or you may choose to install a vinyl-coated wall covering or carpeting on the walls, or a combination of these. Maintenance ease is extremely important in choosing wall covering.

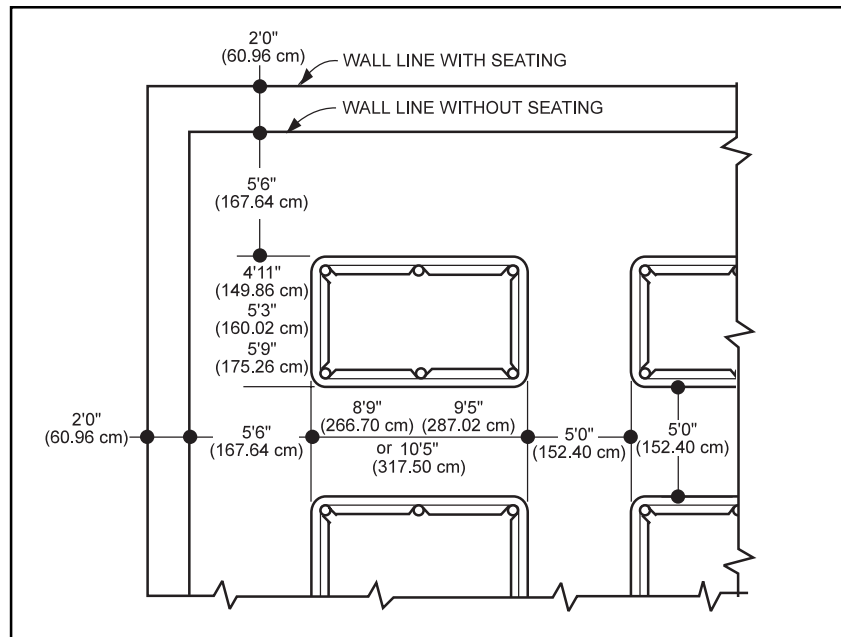

Billiard Table and Spacing Dimensions

Electronic Game Room

Depending upon local laws, game rooms in which video, pinball, and other electronic and mechanical games are presented in a proper environment can add much to the success of the center. Care should be exercised in locating the game area so employees are able to supervise the area from the control desk.

Multi-Purpose Rooms

Meeting rooms and playrooms are often combined to perform dual purposes. Scheduling then becomes important in order to avoid overlap. You should also consider what is required for this room - storage closets, rest room facilities, video equipment, and secondary exit.

Carpeting or vinyl tile can be used on the floor of the children's playroom. Wall covering and flooring should be easy to wash and resist marring. Interior colors can be colorful or more neutral, depending on your choice. Some areas of the country require square footage minimums per child, and also, licensed attendants. Check in advance of construction as to requirements in your area.

Locker Areas

Locker areas should be located in the concourse, in close proximity to rest rooms. These areas can accommodate both men and women to conserve space and provide for family use of one locker. Locker room floors can be carpeted, preferably with the new static-control carpet now available. The area should be well lighted and ventilated. It is not advisable to have the locker area as part of the rest room area, or to be enclosed. Lockers should run perpendicular to the control counter for security purposes.

Rest Rooms

Rest rooms are areas of heavy traffic and require constant maintenance. With this foremost in mind, rest rooms should be designed for ease of maintenance and simple usage. Walls constructed of a glazed brick finish or ceramic tile reduce problems of vandalism and defacing. Floors are best covered with a ceramic tile for long durable wear and easy cleaning. Paper rollers and soap dispensers can be purchased through many manufacturers in recessed styling to reduce breakage. Toilets can be wall-mounted, which permits fast floor maintenance. Diaper changing facilities may be considered. Electric hand dryers are more sanitary than paper towels and less expensive over time. Plan to have good ventilation; exhaust must be directed outside, not returned to the circulation system of air conditioning. Lighting should be approximately 50 footcandles. Floor drains are recommended.

Building Maintenance Equipment Storage Area

The maintenance equipment storage area is best located at the front of the lanes, usually of the concourse. It should be ventilated to the outside and contain a deep sink and storage area for general clean up supplies. The minimum size recommended is 4' 6" x 6' 8" (1.37 m x 2.03 m).

Bowling Maintenance Area

An area should be set aside for the center mechanic to store tools parts manuals and other maintenance supplies. The area should include a work bench. Ideal location is behind pinsetters near the center of the lanes. Size is dependant on number of lanes and amount of spare parts. A center with 12 lanes or less should plan for a 9' x 12' (approximate) room.

Manager's Office and Computer Room

The main reason for this office is to have an area for the manager or book-keeper to perform the necessary clerical duties, material ordering, and record keeping. This office should be able to supervise the control counter nearby. The floor should be vinyl tile. Decorating is generally light and cheerful for maximum work efficiency. Provide adequate lighting for work efficiency. Larger centers will require office space for computer rooms, telephone solicitation, etc.

Food and Beverage Areas

This area should be decorated in lively, bright colors conducive to food consumption. Generally, this serves as a counter-carryout for food to be taken to spectator seating area tables. Maintenance of walls, ceiling, floors, counters, and equipment is of prime importance and the careful selection of these materials is recommended. Avoid flammable or toxic smoke-producing materials. Air conditioning and exhaust of cooking odors require careful planning. Automatic fire extinguishing systems should be installed over grills and deep fat fryers and in hood/duct assemblies. Maximum safety is extremely important. Walls and floors should be readily cleanable - materials such as ceramic tile and plastic laminate should be considered. If fluorescent lighting is used, lamps should be warm white to enhance the color of the food.

Lounge/Bar

The location of a lounge/bar within the bowling center is of prime importance and is related to local laws, traffic flow, and local area drinking habits. Should bowlers enjoy alcoholic beverages while bowling, for example, perhaps only a quick service bar is required. This could be used on the concourse area as well as the lounge itself. Normally, some food service should be available - often quickly accomplished by having the bar and snack bar in adjoining areas with a common quick-service counter.

Size in terms of seating capacity may be governed by local or state ordinances. State and municipal ordinances also govern the construction of walls and entrances for places where alcoholic beverages are sold and/or consumed.

Be certain to provide for storage areas for supplies. Liquor storage should be locked. Beer requires storage, precooling, and empty bottle storage and sorting areas. Easy access from the street is also necessary for deliveries. A common kitchen area could accommodate both the cocktail lounge and food and beverage to save space.

Concrete Floor

Bowling lanes are installed on a waterproof, reinforced concrete slab poured over compacted fill. In the lane area, the surface **must be power-troweled and level to within 1/2" (1.27 cm)**. Care must be exercised to maintain a close tolerance (1/2" or 1.27 cm) on levels to avoid excessive shimming on lane foundations. Due to size, these floors are usually poured in strips rather than in one pour. Be sure to "key" the concrete to insure the waterproof quality and to avoid "heaving" at a later date.

The need for, type, and location of expansion joints must be determined by the architect. **Your architect or engineer must certify on the floor loading certificate, provided by Brunswick, that the floor will meet our requirements in this area.**

IMPORTANT: Concrete in bowlers' seating area should be thick enough to accept a 2-1/2" (64 mm) anchor for seating and other related equipment. Refer to Concrete Floor Layout page 2-3.

Vapor Barrier

Brunswick recommends the concrete floor be poured over a properly installed vapor barrier. The polyethylene materials can be used for this in most cases. Extra care is needed in placing the concrete to prevent the barrier from being torn or punctured. It should also be placed so it will not be punctured when bowling equipment is fastened to the floor.

Termite Proofing

In some areas where the problem exists, the soil beneath the building should be treated to prevent termite penetration. Consult your local pest control authority.

Pipes, Drains, etc.

Pipes, drains, or ducts which could break or require replacement should never be placed in or below the concrete in the lane area.

Before pouring concrete, all conduit or wireways must be securely placed and checked for accuracy of location.

NOTE: Refer to GS Pinsetter and Brunswick Scoring Preinstallation manuals for proper placement of conduits. As always the Brunswick Service department is available for clarification.

Hardening and Dust-proofing

The pinsetter area and service aisles should be power-troweled, hardened, and dust-proofed concrete for reasons of maintenance. **All concrete not covered with tile or floor covering should also be permanently sealed.**

Drying Time

Since wood products can be affected by excess moisture, it is the customer's responsibility to provide conditions conducive to installation on site. Concrete drying time can vary. Consult your architect and cement contractor to insure cement is completely dry.

Brunswick®

Floor Loading Certification

I, by signing this document certify to Brunswick Corporation and to the proprietor named below, that:

1. I am an Engineer/Architect licensed by and in good standing with the state of _____; and
2. I have examined the floor loading diagram for Brunswick Bowling equipment and that I have examined the premises, especially the _____ floor on which the Brunswick Bowling Equipment is to be installed at, _____
3. I further certify that the _____ floor of the premises which I examined will support _____ lanes of Brunswick Bowling equipment.

(Print Name of Architect or Structural Engineer)

(Signature of Architect and Date)

(Title)

(License Number)

(State of)

Seal

Certification and Release and of Brunswick by Proprietor

I, _____ as proprietor or as duly-authorized representative of the proprietor, certify to Brunswick Bowling and Billiards and Brunswick Corporation that:

1. The proprietor has obtained the above floor loading certification for the proprietor's own benefit; and
2. The proprietor is not relying on Brunswick for assurance that the floor structure described in the "Floor Loading Certification" will support the GS Pinsetters with kickbacks selected by proprietor and installed by Brunswick.

In consideration of Brunswick's agreement to install the GS Series pinsetters, and by signing below, proprietor for proprietor's own self and for proprietor's heirs, successors, assigns, employees, agents, representatives, insurers, contractors, subcontractors, invitees, and their spouses and relatives ("Proprietor Group"), releases and agrees to indemnify Brunswick, its officers, directors, employees, shareholders, parent company, subsidiaries, and affiliated companies, insurers, agents, contractors, and subcontractors from all claims, demands, action, cause of action, or their functional equivalent, that any member of the Proprietor Group may have or which may subsequently accrue to a member of the Proprietor Group arising out of or connected with, directly or indirectly, they inability of the floor structure described in the above "Floor Loading Certification" to support the GS-Series pinsetters installed by Brunswick in accordance with the floor loading specifications on the reverse side of the sheet.

Send To:
Contract Management
Brunswick Bowling and Billiards Corporation
Post Office Box 329
Muskegon, MI 49443-0329
or Fax: 231-725-3364

(Print Name of Proprietor or Corporate Officer)

(Signature and Date)

(Title)

Floor Loading Diagrams

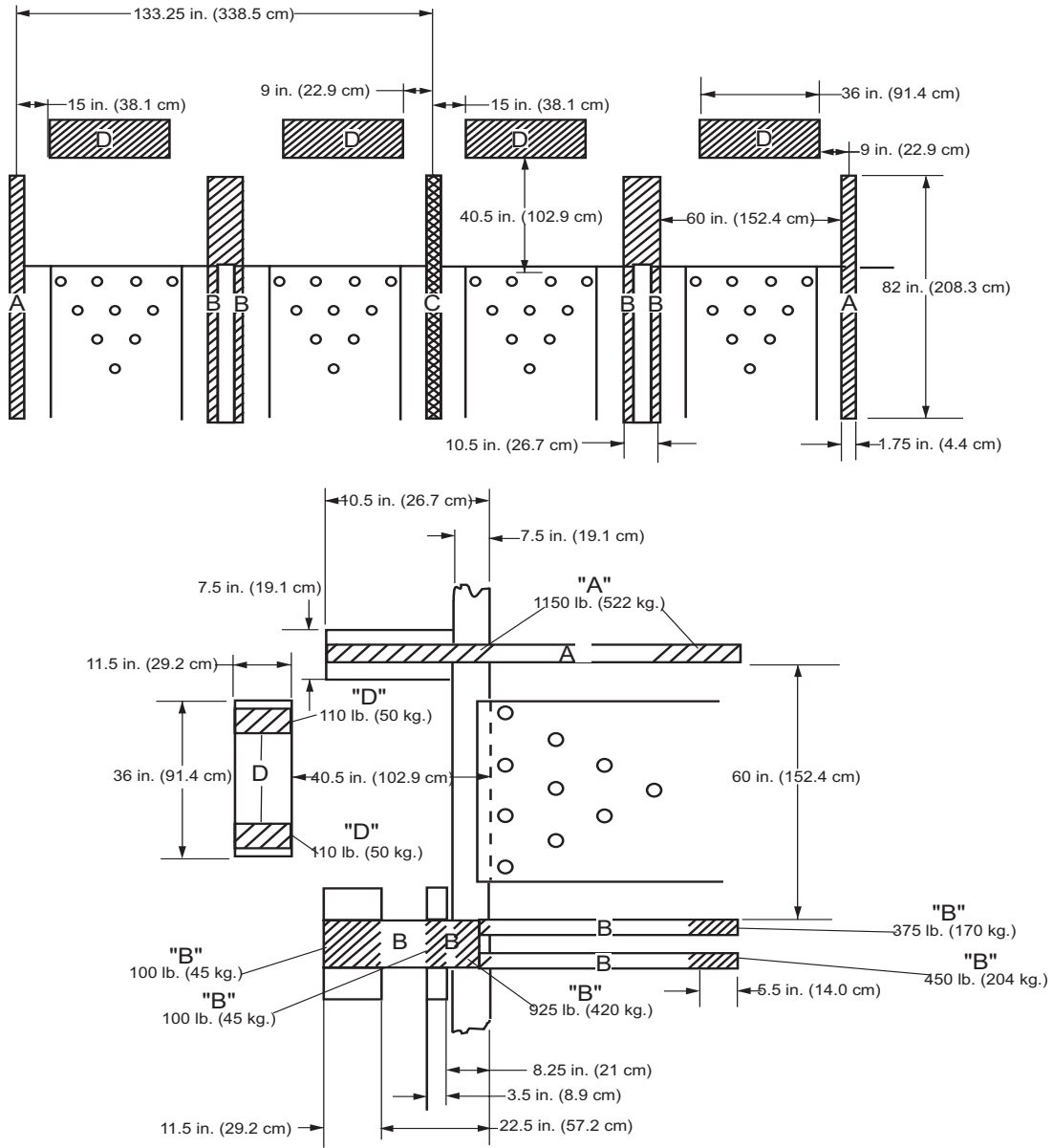

GS-Series Pinsetter Floor Loading Diagram

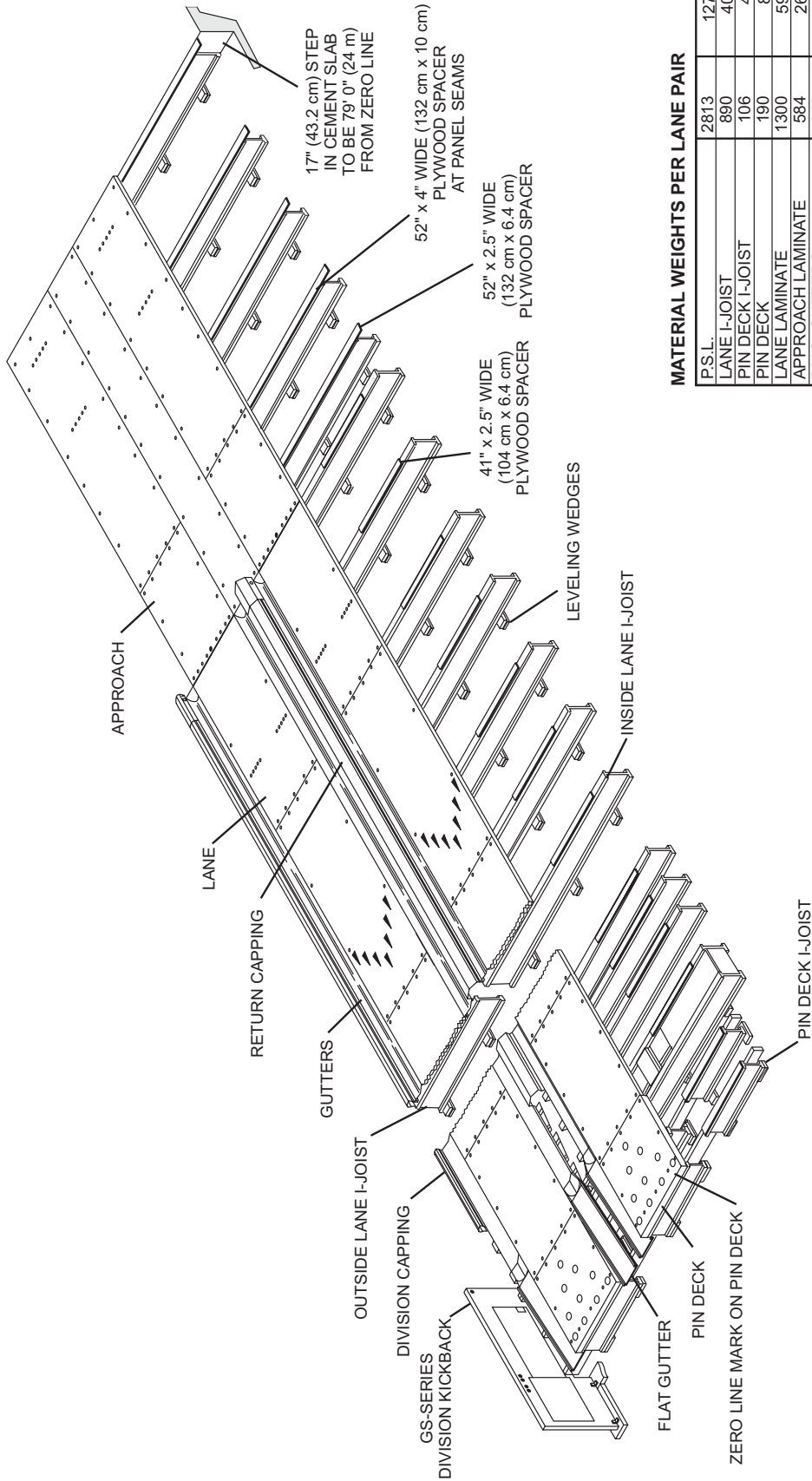

MATERIAL WEIGHTS PER LANE PAIR

P.S.L.	2813	1276
LANE I-JOIST	890	404
PIN DECK I-JOIST	106	48
PIN DECK	190	86
LANE LAMINATE	1300	590
APPROACH LAMINATE	584	265
P.V.C. GUTTERS	240	109
P.V.C. DIVISION CAPPING	40	18
P.V.C. RETURN CAPPING	125	57
CAPPING SUPPORT LUMBER	280	127
PLYWOOD SPACERS	100	45
TOTAL	6,688 Lbs.	3,025 kg.

NOTE: FOR PINSETTER WEIGHTS REFERENCE PAGE 2-16.

Upper Floor Installation

Construction

Where lanes are to be installed on the second floor or higher, you must provide a floor strong enough to carry the load of the bowling equipment and public occupancy with the proper safety factors. Of equal importance is consideration of the transmission noise to spaces below the lanes. Your floor must be constructed to isolate and inhibit noise and vibration transmission. The Brunswick Floor Loading Certificate (page 2-16) must be signed and certified by your architect or engineer.

Acoustic Considerations

It may be necessary to hire an acoustical engineer when lanes are to be installed on a floor where the space below the lanes is to be occupied for any use that would be sensitive to sound, a careful study of the space should be made BEFORE the installation on the floor. The following facts are to be considered:

1. It is the responsibility of the building owner or the customer to provide a floor of the proper floor loading capacity to support the weight of the installation without undue vibration.
2. For acoustical treatment of the area below the bowling spaces, it should be remembered that solid mass prevents sound from penetrating through the floor.
3. There should be ample clearance between lanes and vertical structural members of the building to prevent transmission of noise through the building.
4. Pay particular attention to the location of pipes and ducts which will conduct noise unless they are properly isolated and insulated.
5. Take into consideration adjacent building areas that may be affected by sound, such as residential, restaurants, theaters and other such businesses.



Second Floor Noise and Vibration Release

I, _____ as proprietor or as duly-authorized representative of the proprietor, certify to Brunswick Bowling and Billiards and Brunswick Corporation that:

In consideration of Brunswick’s agreement to install GS Series Pinsetters and/or Bowling Lanes, and by signing below, proprietor for proprietor’s own self and for proprietor’s heirs, successors, assigns, employees, agents, representatives, insurers, contractors, subcontractors, invitees, and their spouses and relatives (“Proprietor Group”), release and agrees to indemnify Brunswick, its officers, directors, employees, shareholders, parent company, subsidiaries, and affiliated companies, insurers, agents, contractors, and subcontractors from all claims, demands, action, cause of action, or their functional equivalent, that any member of the Proprietor Group may have of which may subsequently accrue to a member of the Proprietor Group arising out of or connected with directly or indirectly, against any claim in connection with or resulting from noise or vibration by the operation of GS Series Pinsetters and/or Bowling Lanes.

(Print Name of Proprietor or Corporate Officer)

(Signature and Date)

(Title)

Seal

Attest: (CORPORATE SEAL HERE)

Notary

Send To:
Contract Management
Brunswick Bowling and Billiards Corporation
Post Office Box 329
Muskegon, MI 49443-0329
or Fax: 231-725-3364

This page Intentionally Blank

Lane Installation Information

Lane Foundations

Anvilane Prolane New Lanes On I-Joist Foundations

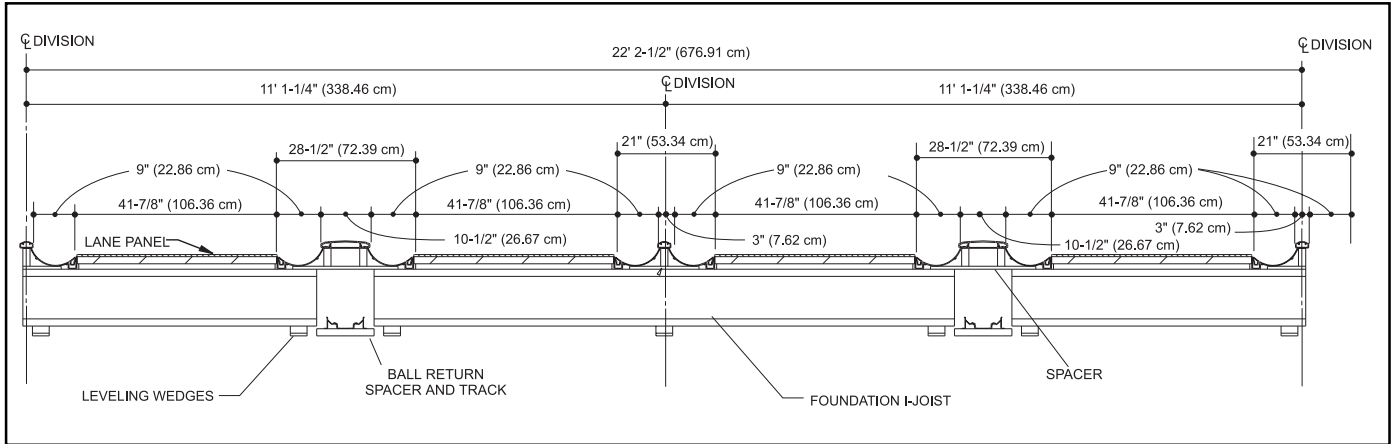

End View

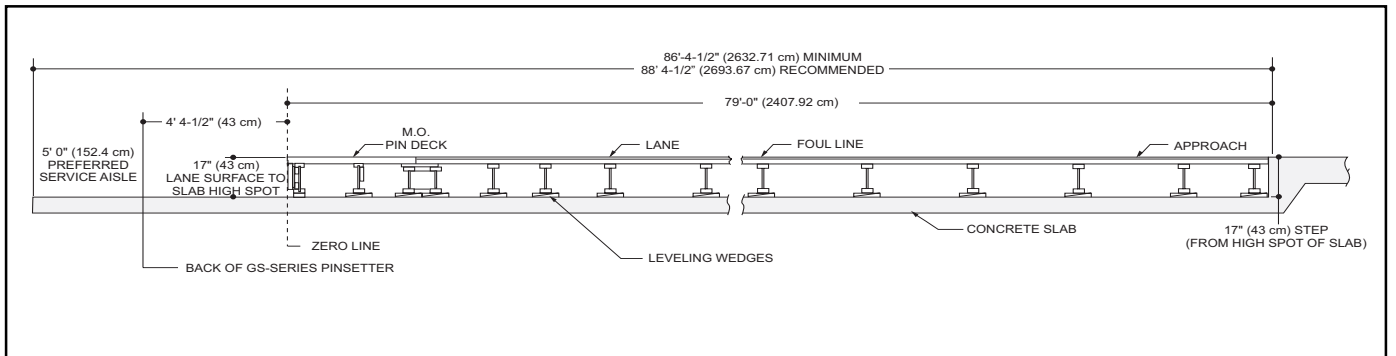

Side View

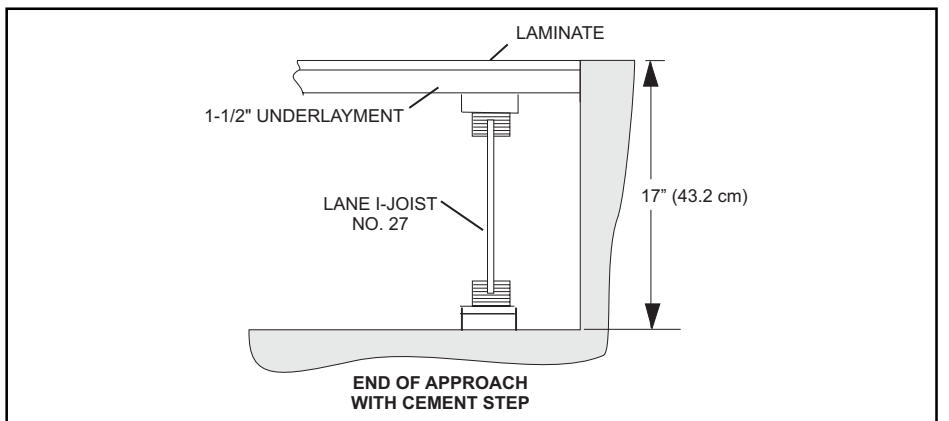

Flush Approach Detail

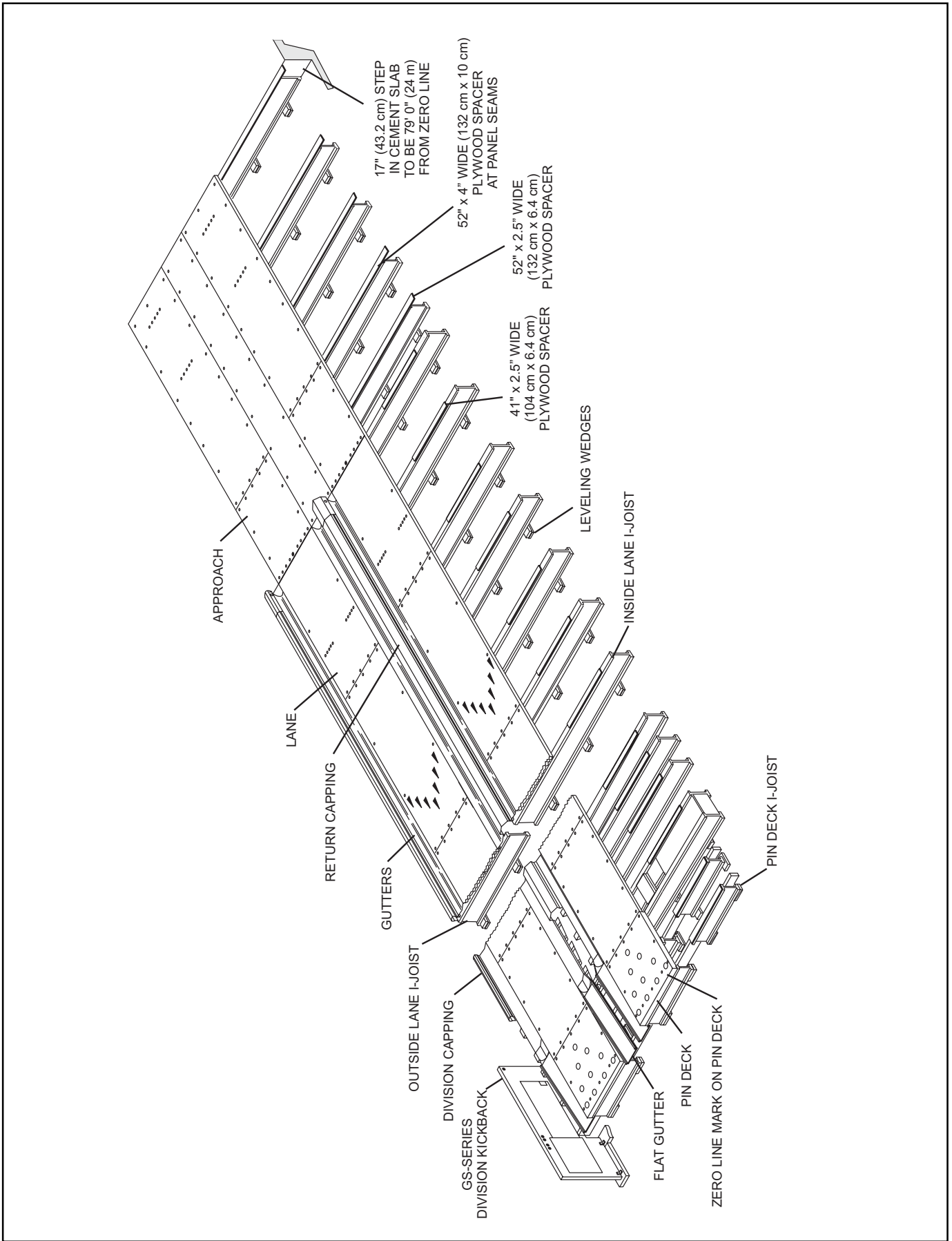

Lane Pictorial

Local Building Codes

The "*Fire Resistant Construction Form*" on following page must be submitted to Brunswick prior to construction.

Local building codes vary from area to area, based on your local code it may be necessary to install draft stops under the lanes. Refer to "*Typical Draft Stop Location*" diagram on page 2-24.



FIRE RESISTANT CONSTRUCTION FORM

The Brunswick lane foundation consists of high pressure laminate mechanically fastened to a wooden underlayment of engineered strand board. The underlayment is spaced above the floor by engineered lumber I-joists. These components do not meet requirements of fire-retardant-treated lumber. It is the responsibility of the proprietor and proprietor's architect to investigate and comply with local building codes. If additional labor and/or materials need to be added to Brunswick's standard installation in order to comply with local codes, it must be done at expense of the proprietor.

Below is some information the architect may find helpful in complying with local codes. The information is taken from the 2000 Edition of the "International Building Code" written by International Code Council. The International Code Council consists of representatives from Building Officials and Code Administrators International, the International Conference of Building Officials and, the Southern Building Code Congress International. The intent of this code was to draft a comprehensive set of regulations for building systems consistent with and inclusive of the scope of their existing model codes. The requirements for bowling lane construction can be interpreted many ways. This code makes clear reference to bowling and lane construction below.

Section 603 of the 2000 Edition of the International Building Code states:

COMBUSTIBLE MATERIALS IN TYPE I and II CONSTRUCTION

603.1 Allowable uses. Combustible materials are permitted in buildings of Type I and II construction in the following applications:

- 7. Finished Flooring applied directly to the floor slab or wood sleepers that are fire stopped in accordance with "Section 716.2.7"

Section 716.2.7 states:

716.2.7 Concealed sleeper spaces. Where wood sleepers are used for laying wood flooring masonry or concrete fire-resistance-rated floors, the space between the floor slab and the underside of the wood flooring shall be filled with an approved material to resist the free passage of flame and products of combustion or fire blocked in such a manner that there will be no open spaces under the flooring that will exceed 100 square feet (9.3m2) in area and such space shall be filled solidly under permanent partitions so that there is no communication under the flooring between adjoining rooms. Refer to "Typical Draft Stop Location" diagram on the following page.

Exceptions:

- 2. Fire blocking is required only at the juncture of each alternate lane and at ends of each lane in a bowling facility.

Brunswick has installed many bowling centers where the proprietor's contractor installed drywall (sheetrock) fireblocking as specified above. However, by signing below, the proprietor acknowledges that it is his sole responsibility to secure appropriate methods, and seek code approval for the fire-resistance-rated construction if required prior to the start of installation, and pay for all associated material and labor.

Print or Type Name of Proprietor or Corporate Officer

Signature

Title

Date

Send To:
Contract Management
Brunswick Bowling and Billiards Corporation
Post Office Box 329
Muskegon, MI 49443-0329
or Fax: 231-725-3364

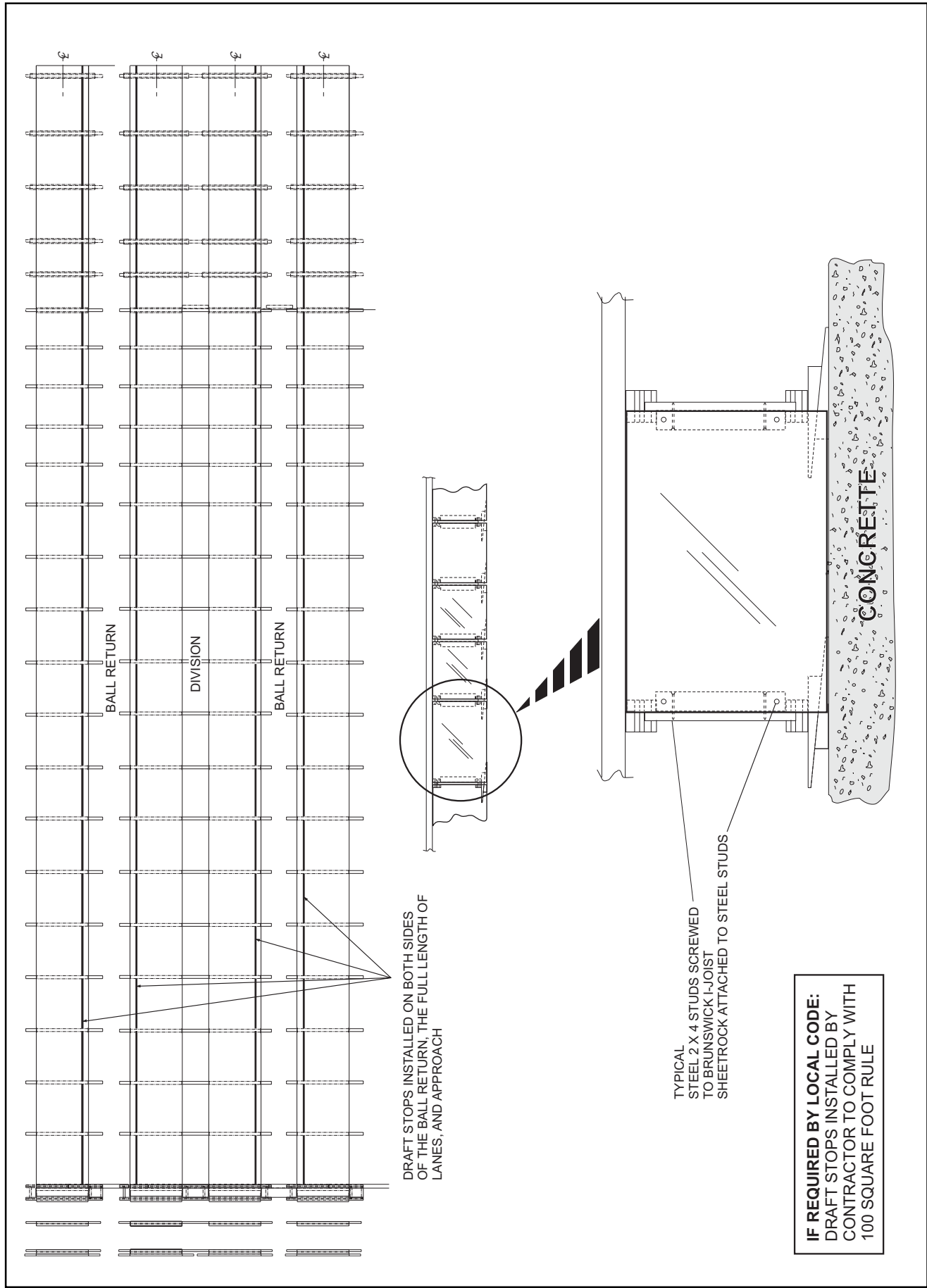

Typical Draft Stop Locations

Ceilings

Clear Span Ceiling

A clear span ceiling is the ideal type for bowling installations. When selected, plan to run roof trusses the full length of the lanes rather than the width. This offers ease of future expansion while still providing a clear span. A catwalk should be installed over the lanes to facilitate maintenance of ceiling and roof, plus electrical wiring inspection. It is necessary to ventilate the truss area between ceiling and roof to prevent mold and discoloration from dampness. Fire barriers between the ceiling and the roof deck will often reflect savings in insurance costs. Be sure to conform to venting requirements in the space between the ceiling and the roof.

For security purposes, rest room and storage area ceilings should be “fixed” rather than suspended.

NOTE: Ceiling is optional over bowling lanes and concourse. If no ceiling is desired, Acoustical considerations should be taken.

Ceiling Height

This height generally ranges from 10' to 12' (3.05 m to 3.66 m) above the approach and lane surface. A 12' (3.66 m) ceiling is recommended for installations to accommodate overhead scoring equipment, special effects lighting, and sound systems in the bowler's area.

Structural Requirements

Regardless of the type of ceiling material selected, a provision should be made for supporting Brunswick scorer overhead equipment. For further information, refer to the Pre-Installation Manual for your scoring equipment.

Typical Ceiling Construction

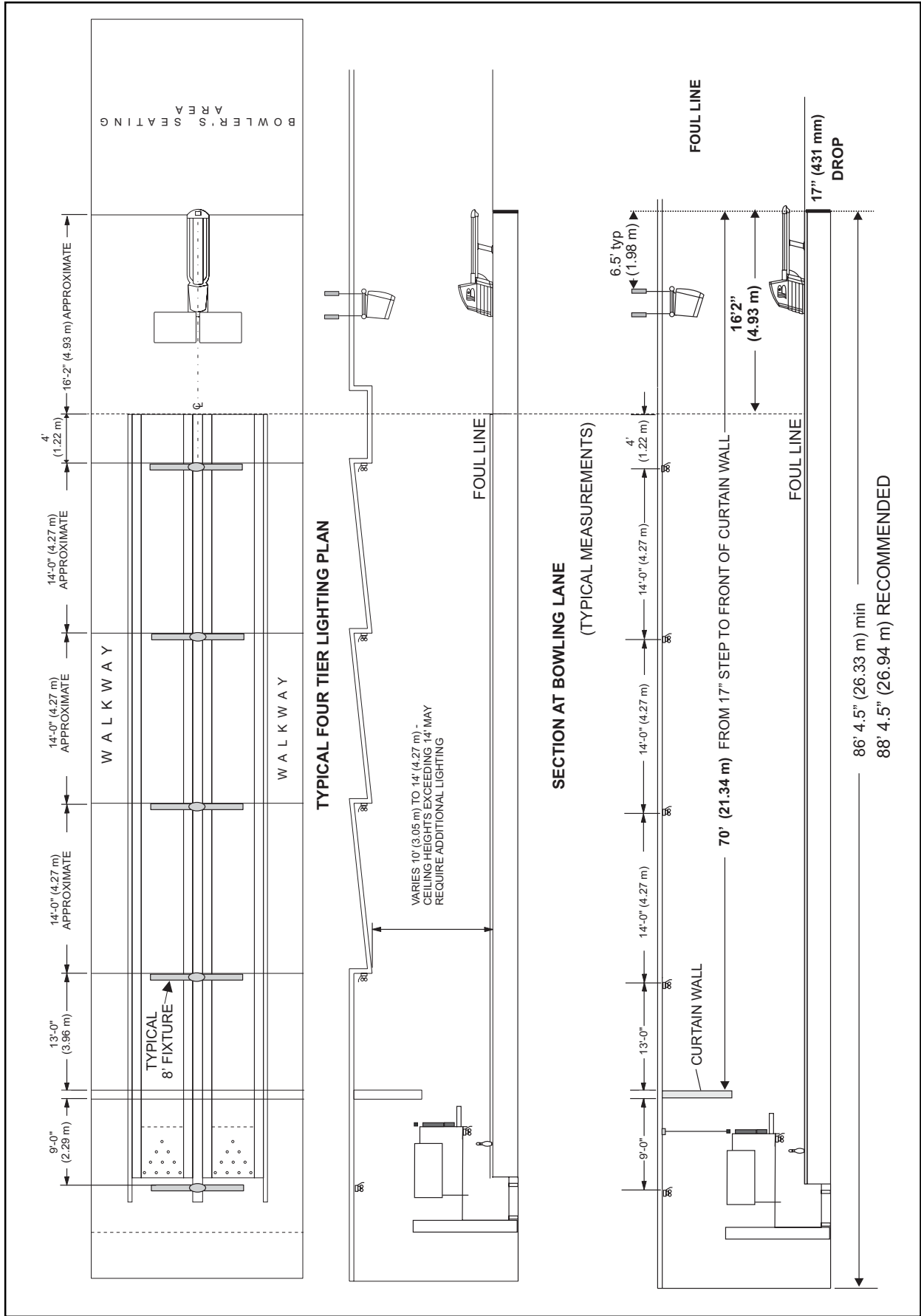

Roof

Your building is only as good as the roof placed over it. A bowling center and all equipment is a capital investment which should be protected as such.

Therefore, Brunswick recommends a recognized brand, solid bondable roof of the highest quality practical be installed over your building. The roof trusses should run the full length of the lanes rather than the width. This offers ease of future expansion while still providing a clear span. Insulation should be considered thoroughly as it affects air conditioning, heating, and humidity within. Reflective finish materials can save you money related to air conditioning. Expansion and contraction of roof surfaces is a vital factor in life of roof and flashing. If roof-mounted signs are considered, plan ahead so it can be in your roof specifications to the contractor. Scuttles, ventilators, louvers, and skylights, where used, should be flashed in the most thorough manner under supervision of the roof contractor and according to specifications and recommendations of roof materials manufacturer. Roof drains and scuttles should have anti-clog and antifreeze devices and should be inspected periodically for damage and service. Any bond should cover the flashing as well as the roofing material. Rooftop air conditioning should be installed over proper curbs. Pitch pot penetrations are not recommended.